

- IT BRUCIATORI DI OLIO DENSO
- EN HEAVY OIL BURNERS
- FR BRULEURS A FIOUL LOURD
- ES QUEMADORES DE FUEL PESADO
- RU ЖИДКОТОПЛИВНЫЕ ГОРЕЛКИ МАЗУТ

Ecoflam



OILFLAM		50.1	PR
OILFLAM	D	50.1	PR
OILFLAM		80.1	PR
OILFLAM	D	80.1	PR
OILFLAM		120.1	PR
OILFLAM	D	120.1	PR
OILFLAM		170.1	PR
OILFLAM	D	170.1	PR
OILFLAM		200.1	PR
OILFLAM	D	200.1	PR

230 / 400 V 50 Hz



420010310100

420010310100

30.06.2010

Indice**1 - Dati tecnici**

- Caratteristiche tecnichep.3
- Campo di lavorop.3
- Dimensioni di ingombrop.4

2 - Installazione

- Montaggio bruciatorep.4
- Alimentazione olio combustibilep.4
- Diagramma pressione pompa/temperatura oliop.5
- Schema alimentazione combustibilep.6

3 - Avviamento e regolazioni

- Verifichep.7
- Funzionamento del bruciatorep.8,9
- Schema idraulicop.9
- Regolazionip.10

4 - Uso e manutenzione

- Pulizia e manutenzionep.11
- Anomalie di funzionamentop.12

CARATTERISTICHE TECNICHE

MODELLO		OILFLAM 50.1	OILFLAM 80.1	OILFLAM 120.1	OILFLAM 170.1	OILFLAM 200.1
Portata termica max.	kcal/h	500.000	800.000	1.200.000	1.462.000	1.800.000
	kW	581	930	1395	1700	2093
Portata termica min.	kcal/h	250.000	400.000	588.000	588.000	588.000
	kW	290	464	682	682	682
Max. portata nafta	kg/h	51	82	122	148	184
Min. portata nafta	kg/h	25,5	41	60	60	60
Max. viscosità		15°E a 50°C				
	versione D	50°E a 50°C				
Tensione di alimentazione	50 Hz V	230/400	230/400	230/400	230/400	230/400
Potenza motore	kW	1,5	1,5	2,2	3	4
Giri -minuto	N°	2.800	2.800	2.800	2.800	2.800
Trasf. accensione	kV/mA	13/35	13/35	13/35	13/35	13/35
Resistenze di lavoro	W	3 x 550	3 x 800	3 x 1350	3 x 1650	3 x 2000
Resistenze di bilanciamento	W	3 x 450	3 x 750	3 x 1000	3 x 1350	3 x 1500
App. controllo fiamma	LANDIS	LMO 44	LMO 44	LMO 44	LMO 44	LMO 44
Combustibile : olio denso		kcal/kg 9.800				

CAMPO DI LAVORO

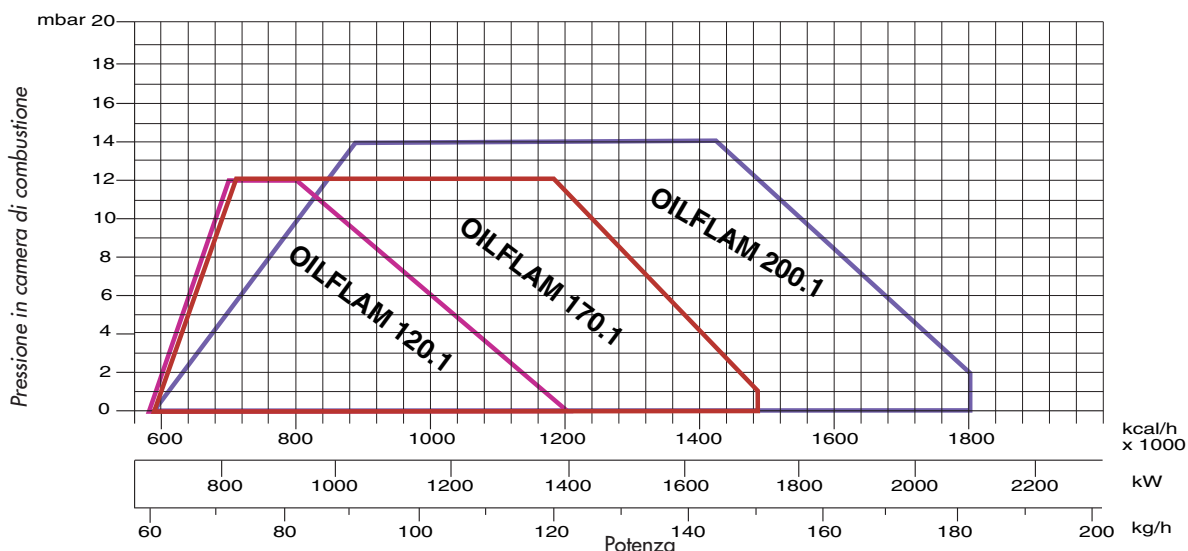
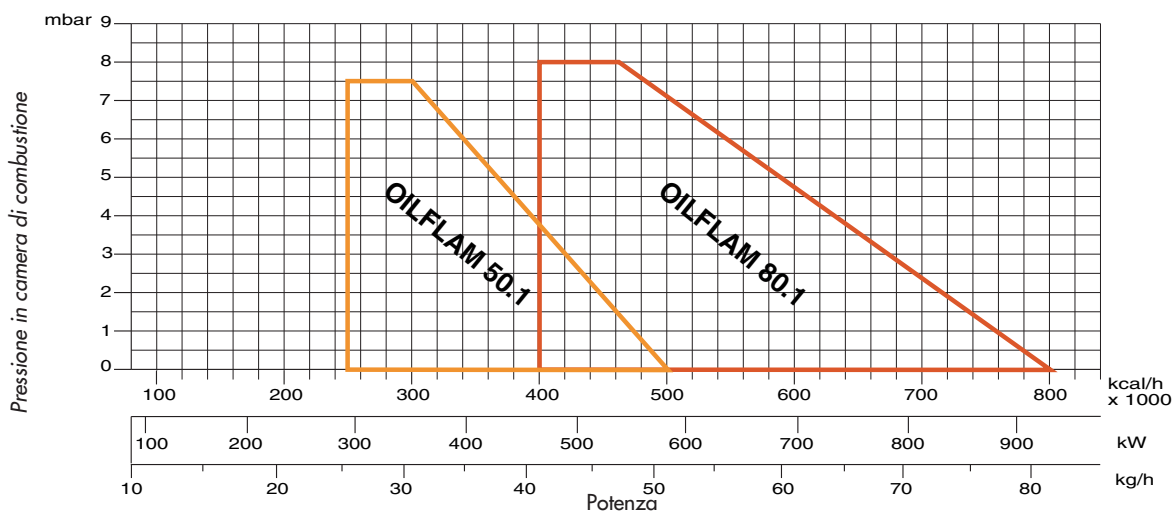

DIMENSIONI D'INGOMBRO (mm)

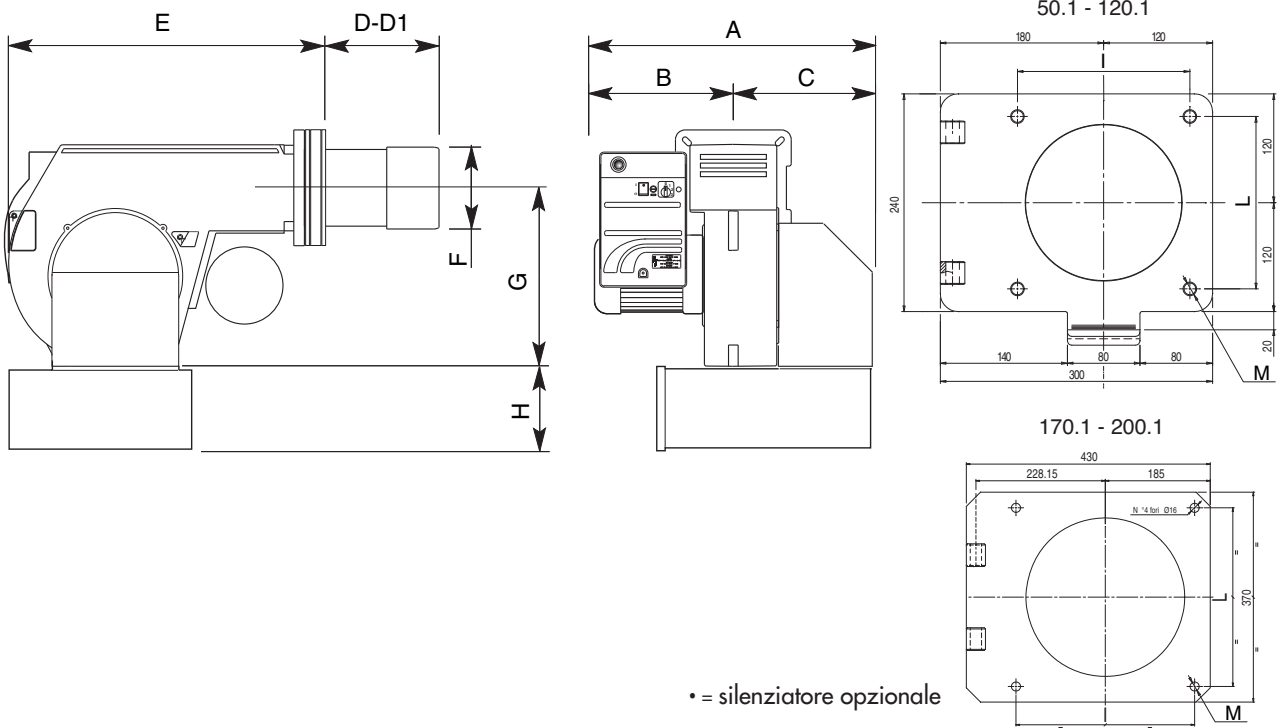

MODELLO	A	B	C	D	D1	E	F	G	H	I	L	M
OILFLAM 50.1 PR	815	370	445	170	310	600	190	376	215•	190	190	M10
OILFLAM 80.1 PR	815	370	445	170	310	600	190	376	215•	190	190	M10
OILFLAM 120.1 PR	815	370	445	170	310	600	190	376	215•	190	190	M10
OILFLAM 170.1 PR	850	400	450	295	455	710	250	398	283•	315	315	M14
OILFLAM 200.1 PR	850	400	450	295	455	710	270	398	283•	315	315	M14

D = testa corta D1 = testa lunga

MONTAGGIO BRUCIATORE

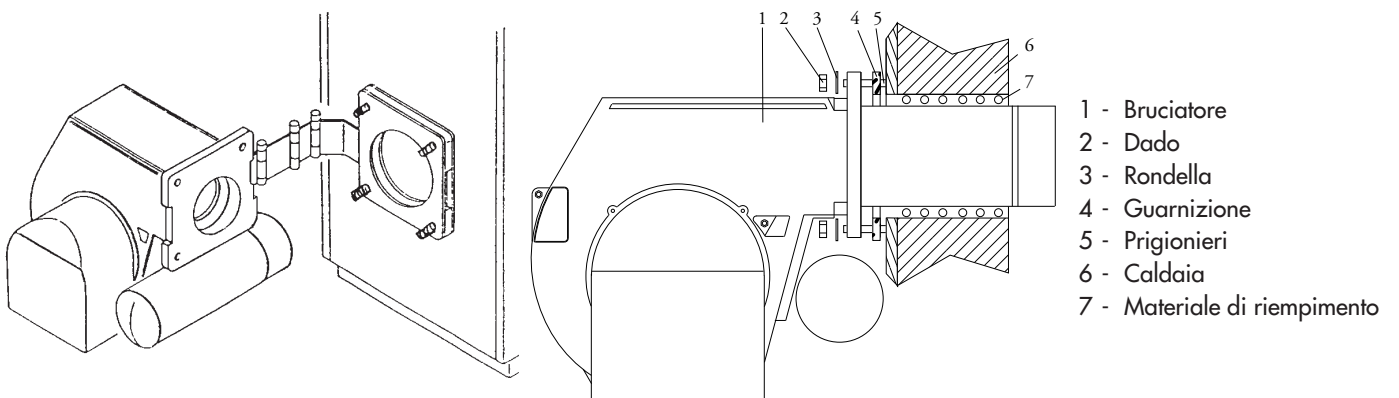

ALIMENTAZIONE OLIO COMBUSTIBILE



DIAGRAMMA PRESSIONE POMPA /TEMPERATURA OLIO

La gasificazione di frazioni volatili contenute nell'olio combustibile riscaldato, risulta essere la causa principale dell'usura prematura della pompa di alimentazione. Per ovviare a tale inconveniente, regolare la pressione della pompa in base al grafico in basso.

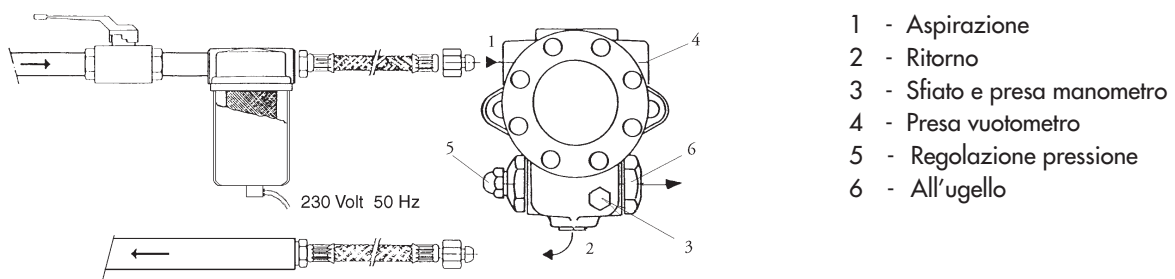
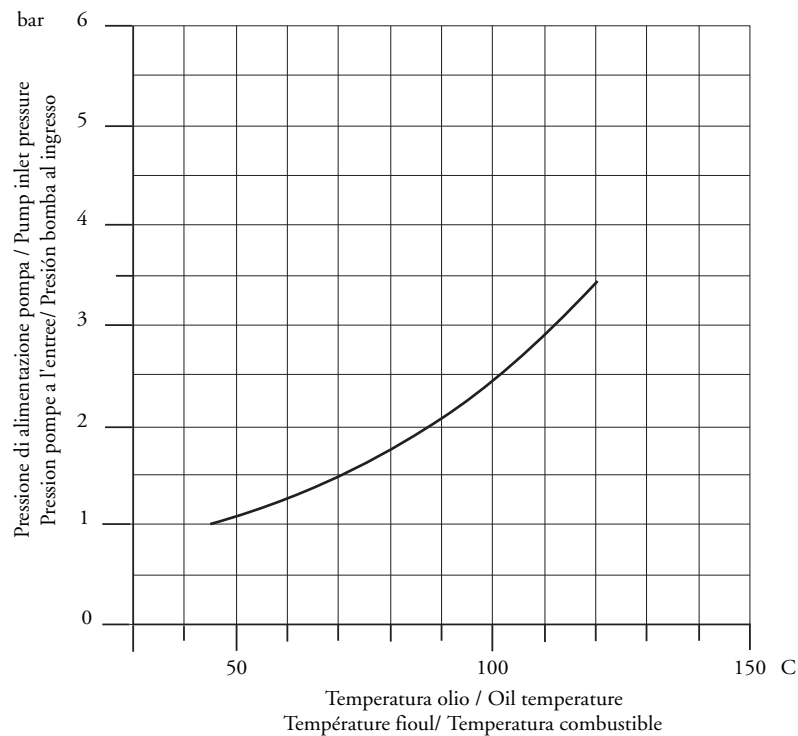

ATTENZIONE: Per un corretto funzionamento della pompa, verificare i dati seguenti:

Pompa :

SUNTEC E..NC 1069

Temperatura del combustibile alla pompa:

Max. 120 °C

Pressioni massime ammissibili

Max. 3,5 bar in ingresso.

SCHEMA ALIMENTAZIONE COMBUSTIBILE FINO A 50°E A 50°C

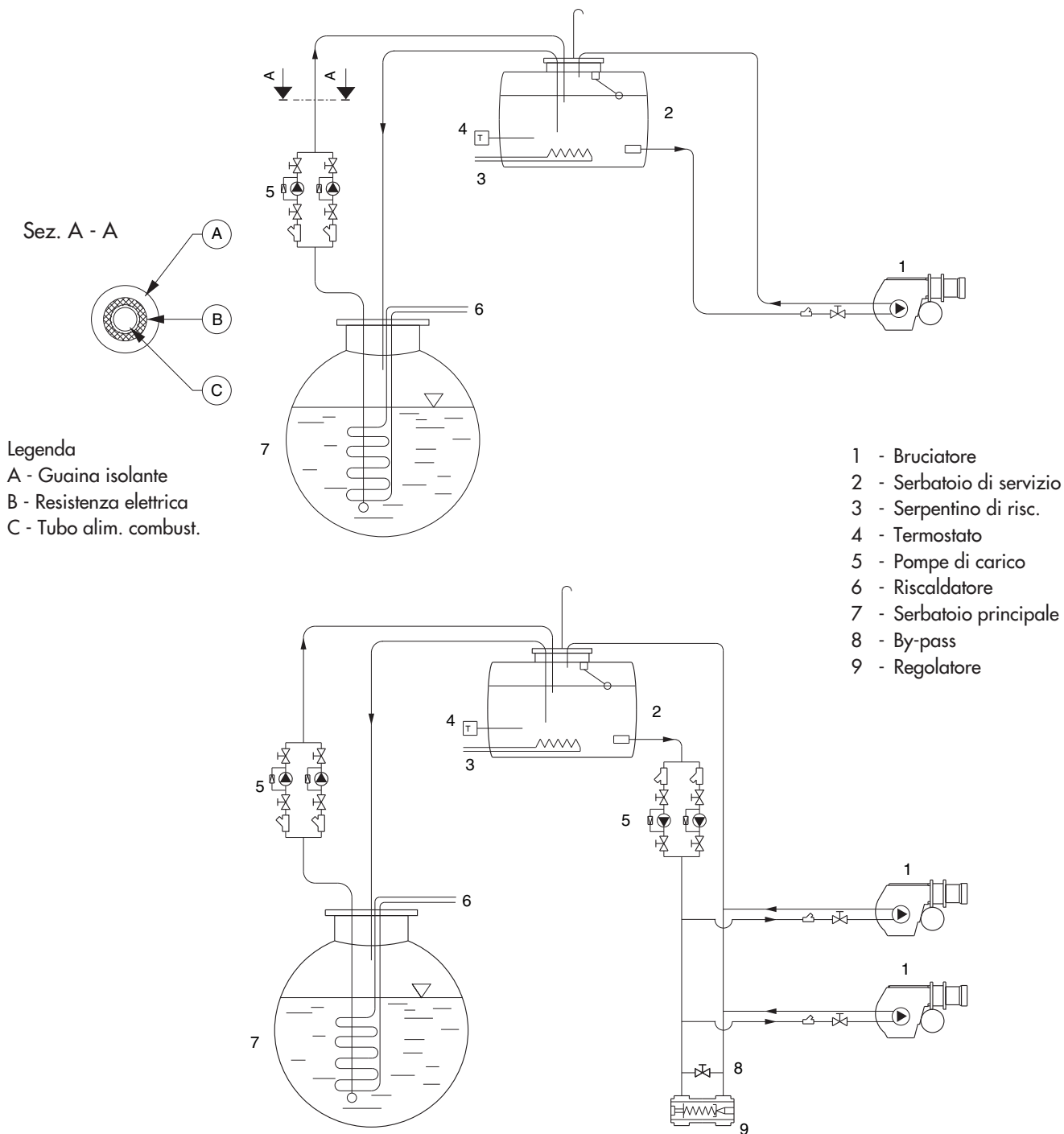

IMPORTANTE: Tutte le linee di alimentazione sono riscaldate (vedi sez. A-A)

VERIFICHE DA EFFETTUARE AI FINI DI UNA CORRETTA INSTALLAZIONE

Prima di procedere al riempimento del circuito di alimentazione e successiva messa in funzione dell'impianto, è consigliabile effettuare i controlli seguenti:

- La linea di alimentazione deve essere adeguata al carico assorbito dall'impianto
- I fusibili devono essere adeguati al carico dall'impianto
- I termostati caldaia devono essere stati collegati correttamente
- Tensione e frequenza devono essere comprese nei limiti specificati
- Il tipo di combustibile deve essere quello prescritto dal costruttore del bruciatore
- La sezione delle tubazioni di alimentazione deve essere adeguata alla portata di combustibile richiesta
- I filtri ed i rubinetti ed i raccordi devono essere stati montati correttamente
- La lunghezza del boccaglio del bruciatore, deve essere quella prescritta dal costruttore della caldaia
- La portata degli ugelli del bruciatore deve essere adeguata alla potenza della caldaia

PRIMA DI PROCEDERE CON IL RIEMPIMENTO DEL CIRCUITO NAFTA EFFETTUARE I SEGUENTI CONTROLLI

- Controllare il senso di rotazione del motore (nella versione trifase).
- Verificare che vi sia combustibile nel serbatoio.
- I rubinetti delle tubazioni devono essere aperti.
- La tubazione di ritorno del combustibile deve essere libera da occlusioni.

Dopo aver effettuato i suddetti controlli, procedere nel modo seguente:

- Inserire un manometro di controllo pressione del combustibile
- Agire manualmente sul teleruttore motore pompa con un cacciavite, sino ad ottenere il riempimento del circuito (fig. B).

Nota: Il circuito potrà ritenersi riempito quando il manometro indicherà una pressione costante.

Una volta riempito, ripristinare le condizioni iniziali.

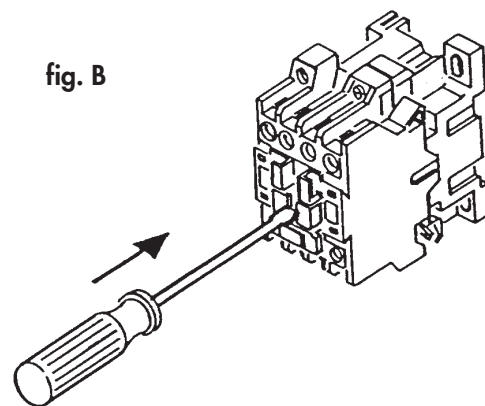

FUNZIONAMENTO DEL BRUCIATORE

Con il bruciatore nella posizione start e i termostati caldaia abilitati, le resistenze (G) del preriscaldatore, le resistenze ausiliarie su pompa e gruppo testa sono sotto tensione. Quando il termostato del preriscaldatore raggiunge il valore fissato, (normalmente è necessario un minimo di 90°C per garantire un buon livello di circolazione) la pompa di avviamento è abilitata (se si usa il dispositivo di termoregolazione GEFRA 200 regolare il set point nell'uscita 1). Se il sistema di preriscaldamento del serbatoio è equipaggiato anche per uno scambiatore di liquidi (acqua calda, vapore, olio diatermico) il termostato può abilitare un contatto nella morsettiera per qualsiasi consenso elettrico dell'elettrovalvola per liquidi. Questa non è una soluzione standard visto che il fluido riscaldato normalmente è sempre in circolazione. La pompa inizia a mandare olio (la testa è già stata riscaldata dalla sua resistenza (O) e perciò non ha residuo di olio denso freddo) che scorre dal serbatoio alla testa e poi alla linea di ritorno dell'anello di alimentazione dell'olio. Quando il termostato della testa raggiunge il valore fissato (normalmente il ciclo comincia in maniera appropriata a circa 70-30°C e l'apparecchiatura dà il consenso all'avvio del bruciatore. Il servomotore si autoposiziona al minimo (vedi il capitolo della regolazione) agendo sulla serranda dell'aria e agendo sul ritorno del regolatore di pressione per l'olio combustibile.

L'elettromagnete (A) apre l'ugello (Q) nella seguente condizione :

- le scintille degli elettrodi di accensione sono generate dal trasformatore che è anche regolato automaticamente dal dispositivo di controllo del bruciatore.

Se la cellula di rivelazione non rivela la fiamma il bruciatore va in blocco.

Una volta che l'accensione è avvenuta e dopo il periodo di stabilizzazione della fiamma, il sistema inizia a operare in modulazione.

- Prima dell'avvio assicurarsi che la pompa e i tubi di mandata siano completamente riempiti con olio combustibile caldo; l'assenza di olio combustibile può causare il grippaggio della pompa.

- Se c'è un blocco, una luce specifica di avvertimento sul programmatore e sul pannello frontale di controllo del bruciatore si illumina e questo segnale è mandato di solito all'apparecchiatura principale usata dal bruciatore, accendendo un allarme acustico e una luce di avvertimento.

- Alcuni blocchi sono normali durante il primo avvio (fino a 4 circa); per sbloccare premere il tasto sull'apparecchiatura (che si trova nella parte anteriore del pannello di controllo del bruciatore) per ripetere il ciclo di avvio. Se dovesse persistere cercate l'aiuto di un tecnico specializzato.

N.B. La posizione dell'apparecchiatura al momento del blocco fornisce un'indicazione della causa di questo blocco.

SOLO PER APPARECCHIATURA LANDIS LMO 44

In caso di blocco è disponibile l'indicazione della causa che ha provocato il blocco. Operare come segue: con l'apparecchiatura in blocco (led rosso acceso) tenere premuto il pulsante di sblocco per più 3 secondi, quindi rilasciarlo. Il led rosso inizierà a lampeggiare indicando la causa secondo la seguente tabella:

Codice errore	Possibile causa
2 lampeggi	Assenza di fiamma al termine del tempo di sicurezza all'accensione «TSA» - elettrovalvole difettose - rilevatore fiamma difettoso - regolazione bruciatore errata - elettrodi difettosi
3 lampeggi	Non utilizzati
4 lampeggi	Luci estranee durante la fase di pre-ventilazione
5 lampeggi	Non utilizzati
6 lampeggi	Non utilizzati
7 lampeggi	Troppe mancanze di fiamma durante il funzionamento (superato il limite del n° di ripetizioni del ciclo) - elettrovalvole difettose - rilevatore fiamma difettoso - regolazione bruciatore errata
8 lampeggi	Controllo del tempo riscaldamento combustibile
9 lampeggi	Non utilizzati
10 lampeggi	Contatti in uscita difettosi o guasto del dispositivo interno

REGOLAZIONE DELLA PRESSIONE DEL RITORNO

Il diagramma illustra il sistema di regolazione del ritorno di gasolio per questi tipi di bruciatori i quali hanno incorporato un ugello con ritorno variabile progressivo. La portata del gasolio può essere variata attraverso l'ugello di ritorno cambiando la pressione nel ritorno. La portata massima di gasolio si ottiene quando la pressione della pompa è di circa 30 bar e il ritorno è completamente chiuso. La portata minima del gasolio si ottiene quando la linea di ritorno è completamente aperta. La pressione in mandata si legge montando un manometro sulla pompa. La pressione del ritorno si legge sul manometro montato a corredo del bruciatore sul regolatore di pressione.

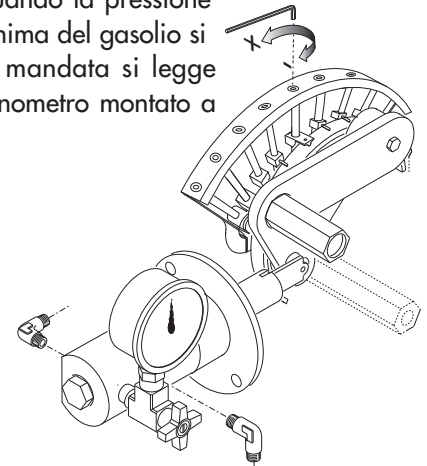

Pressione pompa 25-30 bar.

Max portata bruciatore, pressione di ritorno:

FLUIDICS ugello : 16 ÷ 19 bar.

BERGONZO ugello : 20 ÷ 24 bar.

Min portata bruciatore, pressione di ritorno:

FLUIDICS ugello : 6 ÷ 9 bar

BERGONZO ugello : 4 ÷ 8 bar

FASE DI PRELAVAGGIO

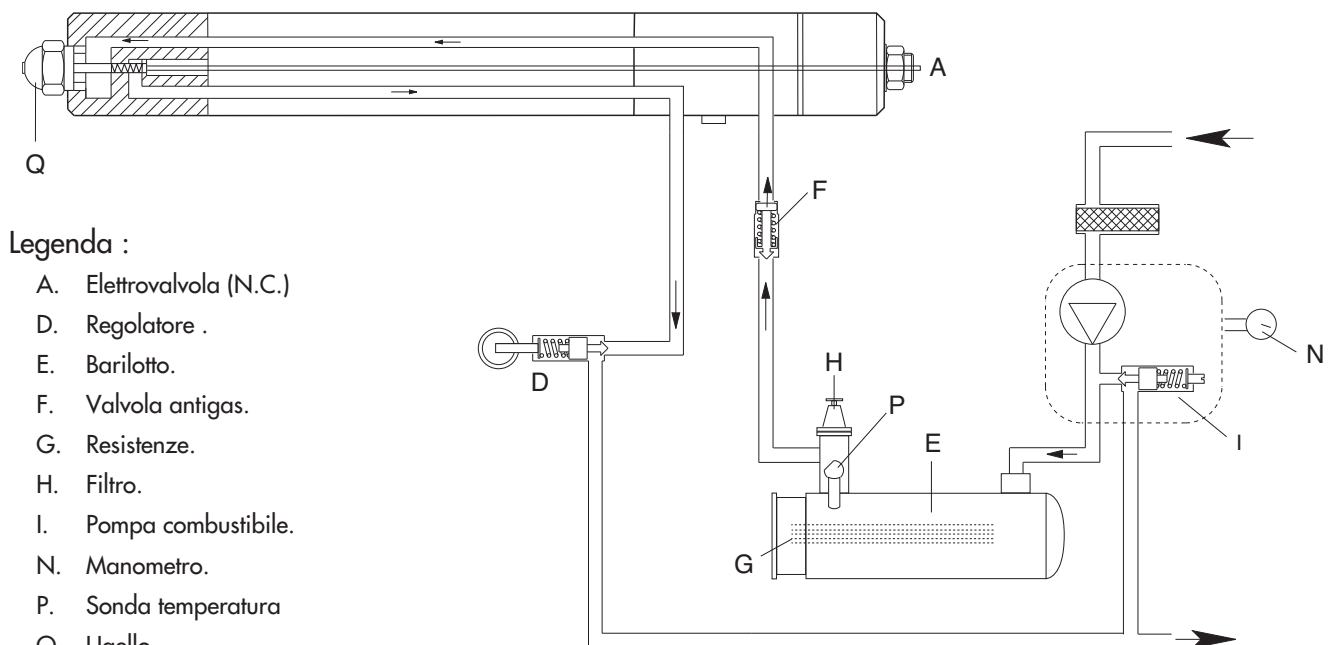

Legenda :

- A. Elettrovalvola (N.C.)
- D. Regolatore .
- E. Barilotto.
- F. Valvola antigas.
- G. Resistenze.
- H. Filtro.
- I. Pompa combustibile.
- N. Manometro.
- P. Sonda temperatura
- Q. Ugello.
- N.C. = Norm. chiusa

REGOLAZIONE DEL MOTORIDUTTORE LANDIS & GYR SQM 50.481A2



Togliere il coperchio per accedere alle camme di regolazione. Lo spostamento delle camme va effettuato con l'ausilio dell'apposita chiavetta in dotazione.

- I - Camma di regolazione aria di massima (potenza max.).
- II - Camma di regolazione aria di accensione.
- III - Camma di regolazione aria di bassa (potenza min.).
- IV - Camma non utilizzata.
- V - Camma non utilizzata.

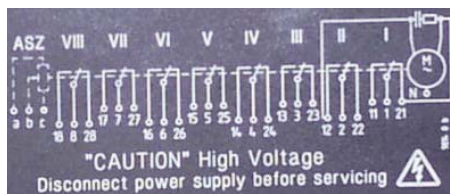

REGOLAZIONE TERMOSTATI OLIO COMBUSTIBILE

Il termostato di lavoro delle resistenze va impostato sui 120 °C e il termostato di sicurezza sui 160 °C. Queste regolazioni possono essere leggermente modificate in funzione del tipo di combustibile e di particolari applicazioni.

- A - Termostato di sicurezza (160° C).
- B - Termostato di lavoro (120° C).
- C - Termostato di livellamento (130° C).
- D - Termostato di min. temperatura olio combustibile (90° C).

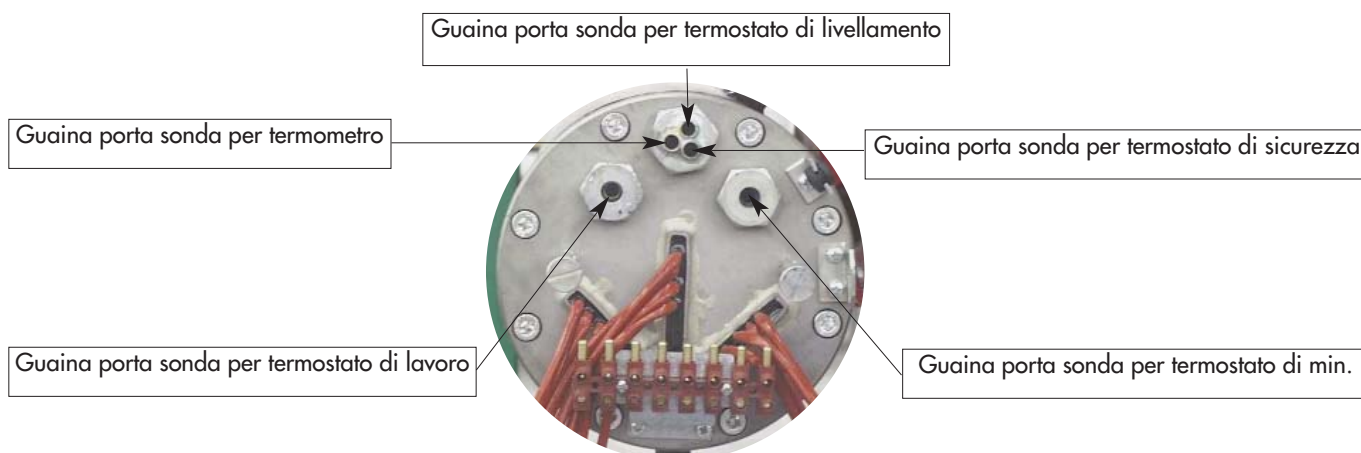
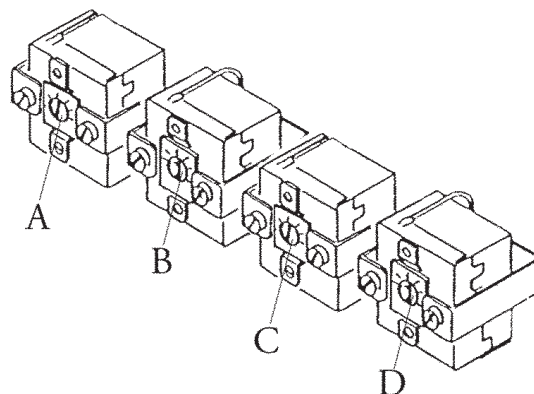

POSIZIONE ELETTRODI DI ACCENSIONE

Per una corretta accensione del bruciatore le quote riportate nel disegno devono essere rispettate.

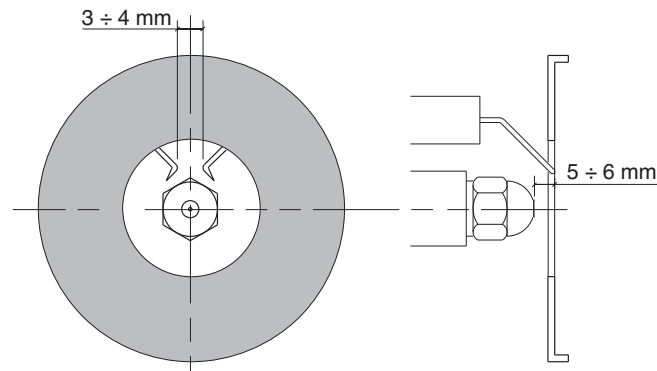

PULIZIA E MANUTENZIONE DEI FILTRI INSERITI NEL BARILOTTO PRERISCALDATORE

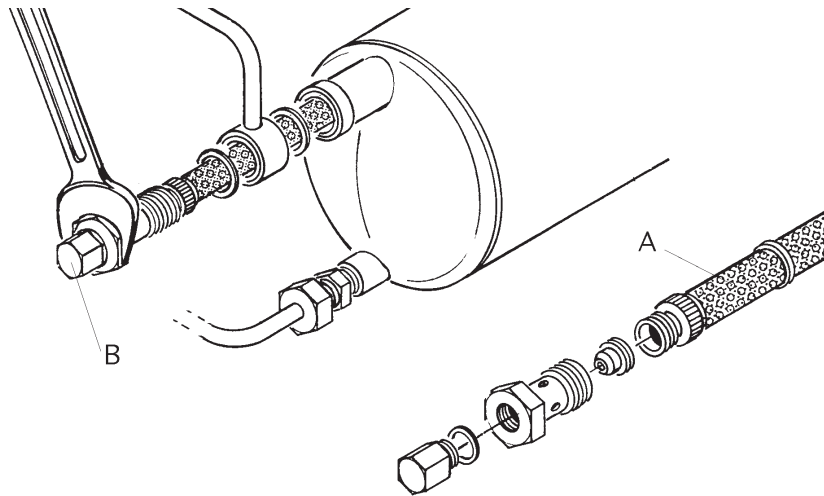

ESTRAZIONE DEL FILTRO

- 1 - Spegner il bruciatore.
 - 2 - Allentare la vite B e scaricare una parte dell'olio contenuto nel barilotto affinché il livello del liquido scenda al di sotto di quello del filtro.
 - 3 - Svitare ed estrarre dalla propria sede il gambo del filtro A..
 - 4 - Dopo aver pulito il filtro, rimontarne le parti come indicato in figura e reinserirlo nella propria sede.
- E' buona norma sostituire tutte le guarnizioni del filtro e della valvola ogni qualvolta questi vengono smontati.

Si ricorda che, quando il bruciatore è in funzione, nel barilotto si ha una pressione di circa 23 bar e che quindi diventa molto pericoloso eseguire le precedenti operazioni con il bruciatore funzionante.

ANOMALIE DI FUNZIONAMENTO**1 - Il bruciatore non parte:**

- Interruttore di avviamento su OFF
- Fusibili saltati
- Termostati caldaia aperti
- Resistenze guaste
- Termostati del barilotto aperti

2 - Le resistenze scaldano ma il bruciatore non parte

- Termostati guasti
- Interruttore in posizione di OFF
- Termostati barilotto aperti
- Apparecchiatura di controllo guasta

3 - Il bruciatore effettua il prelavaggio e va in blocco

- Interruttore in posizione OFF
- Apparecchiatura di controllo guasta
- Fotoresistenza guasta
- Innesco di fiamma prematuro a causa del trafileamento di olio dall'elettrovalvola

4 - Durante il ciclo il bruciatore non si accende, quindi va in blocco

- Apparecchiatura di controllo guasta

5 - Il bruciatore non si accende

- Elettrodi sporchi
- Elettrodi rotti
- Elettrodi mal posizionati
- Trasformatore di accensione guasto
- Valvola di 1° Stadio guasta
- Ugelli otturati
- Eccesso di aria comburente in rapporto alla portata degli ugelli
- Apparecchiatura di controllo guasta

6 - Il bruciatore si accende poi va in blocco

- Temperatura dell'olio troppo bassa (fiamma irregolare)
- Eccessiva usura degli ugelli
- La fotoresistenza non percepisce la fiamma
- Pressione dell'olio troppo bassa durante il prelavaggio
- Eccesso di aria comburente in rapporto alla portata degli ugelli
- Apparecchiatura guasta
- Pressione olio troppo bassa
- Filtri intasati

7 - Il bruciatore non passa in 2° Stadio

- Interruttore man. in posizione I (1° Stadio)
- Bobina 2° Stadio guasta
- Pressione olio troppo bassa
- Filtri intasati
- Ugello di 2° Stadio usurato od ostruito
- Apparecchiatura di controllo guasta

8 - Pressione dell'olio troppo bassa od irregolare

- Filtri pompa e/o barilotto intasati
- L'elettrovalvola norm. aperta non si chiude
- Alimentazione olio irregolare
- Pompa guasta

Index**1 - Technical data**

- Technical datap.14
- Working fieldsp.14
- Overall dimensionsp.15

2 - Installation

- Burner installationp.15
- Heavy oil feedingp.15
- Pump's pressure/oil temperature diagramp.16
- Heavy oil feed systemp.17

3 - Starter and regulations

- Verificationsp.18
- Working of the burnerp.19,20
- Hydraulic systemp.20
- Regulationsp.21

4 - Use and maintenance

- Cleaning and maintenancep.22
- Troubleshootingp.23

TECHNICAL DATA

MODELS		OILFLAM 50.1	OILFLAM 80.1	OILFLAM 120.1	OILFLAM 170.1	OILFLAM 200.1
Thermal power max.	kcal/h	500.000	800.000	1.200.000	1.462.000	1.800.000
	kW	581	930	1395	1700	2093
Thermal power min.	kcal/h	250.000	400.000	588.000	588.000	588.000
	kW	290	464	682	682	682
Max. oil flow rate	kg/h	51	82	122	148	184
Min. oil flow rate	kg/h	25,5	41	60	60	60
Max. viscosity		15°E α 50°C				
	version D	50°E α 50°C				
Feeding power	50 Hz V	230/400	230/400	230/400	230/400	230/400
Motor power	kW	1,5	1,5	2,2	3	4
Rpm	N°	2.800	2.800	2.800	2.800	2.800
Ignition transformer	kV/mA	13/35	13/35	13/35	13/35	13/35
Main resistances	W	3 x 550	3 x 800	3 x 1350	3 x 1650	3 x 2000
Balancing resistances	W	3 x 450	3 x 750	3 x 1000	3 x 1350	3 x 1500
Control box	LANDIS	LMO 44	LMO 44	LMO 44	LMO 44	LMO 44
Fuel : heavy oil		kcal/kg 9.800				

WORKING FIELDS

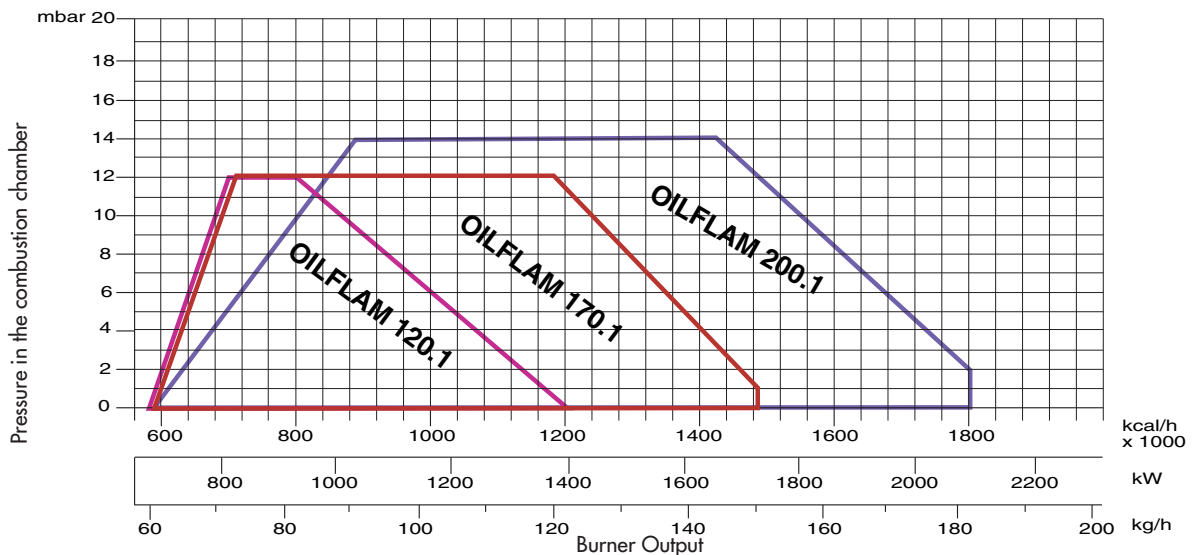
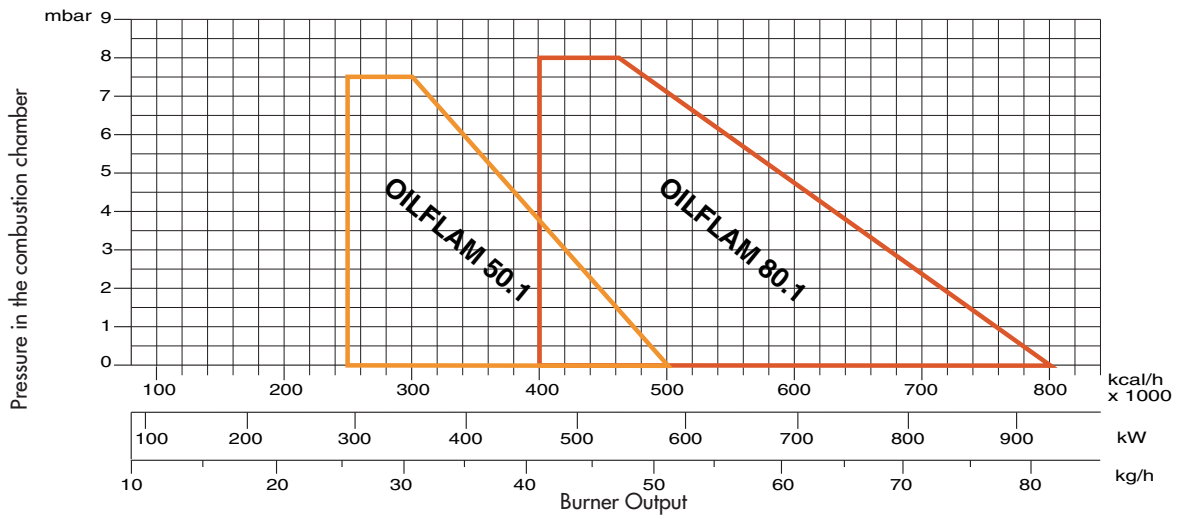

OVERALL DIMENSIONS (mm)

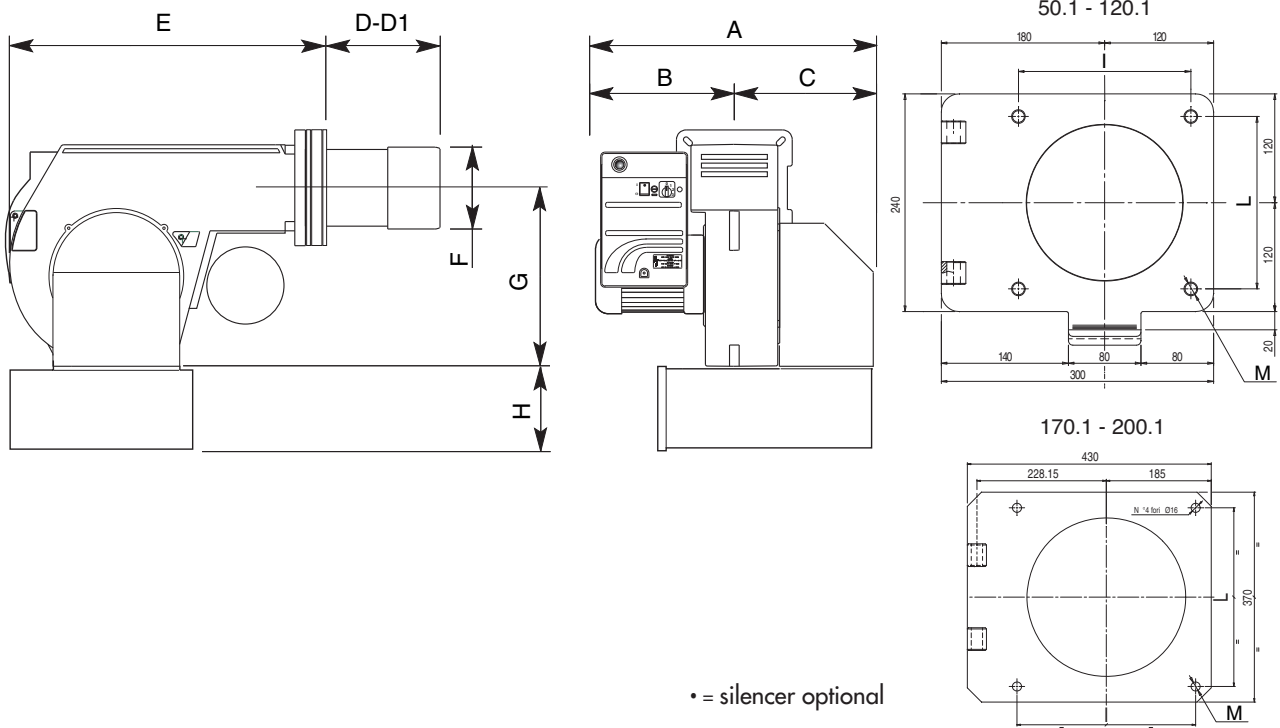

MODELS	A	B	C	D	D1	E	F	G	H	I	L	M
OILFLAM 50.1 PR	815	370	445	170	310	600	190	376	215●	190	190	M10
OILFLAM 80.1 PR	815	370	445	170	310	600	190	376	215●	190	190	M10
OILFLAM 120.1 PR	815	370	445	170	310	600	190	376	215●	190	190	M10
OILFLAM 170.1 PR	850	400	450	295	455	710	250	398	283●	315	315	M14
OILFLAM 200.1 PR	850	400	450	295	455	710	270	398	283●	315	315	M14

D = short head D1 = long head

BURNER INSTALLATION

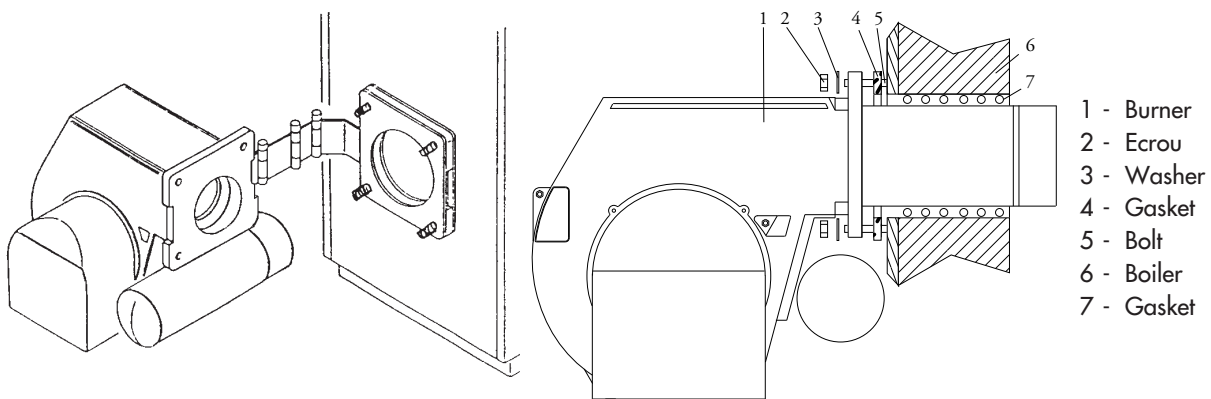

HEAVY OIL FEEDING

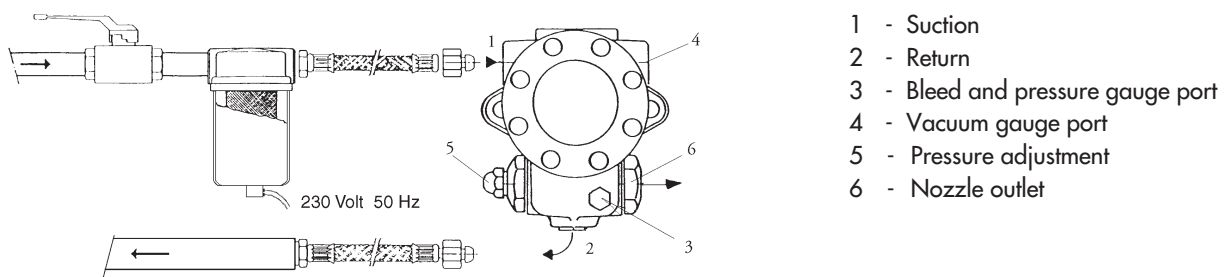

PUMP'S PRESSURE / OIL TEMPERATURE DIAGRAM

The gasification of volatile fractions in preheated heavy oil seems to be the main cause of premature fuel pump wear. To avoid such a problem, adjust pump pressure according to the diagram hereinafter.

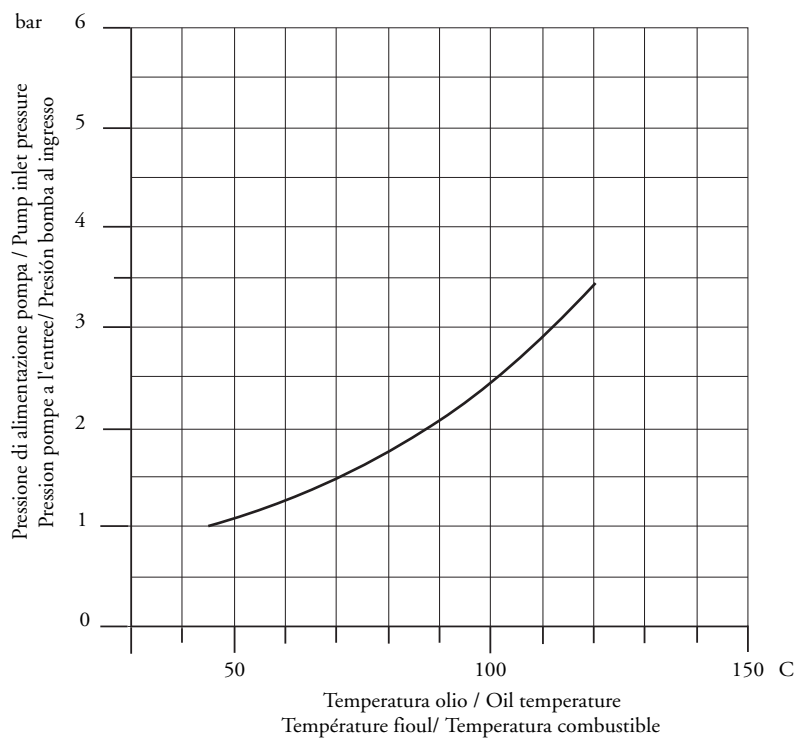

WARNING: For a correct working of the pump, verify what follows:

Pump :

SUNTEC E..NC 1069

Oil temperature at the pump:

Max. 120 °C

Maximum allowable pressures:

Max. 3,5 bar on inlet.

HEAVY OIL FEED SYSTEM UP TO 50°E AT 50°C

Sez. A - A

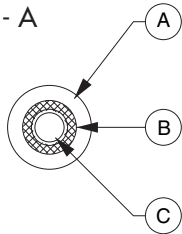

Legend

- A - Isolating sheath
- B - Electric resistance
- C - Fuel feed piping

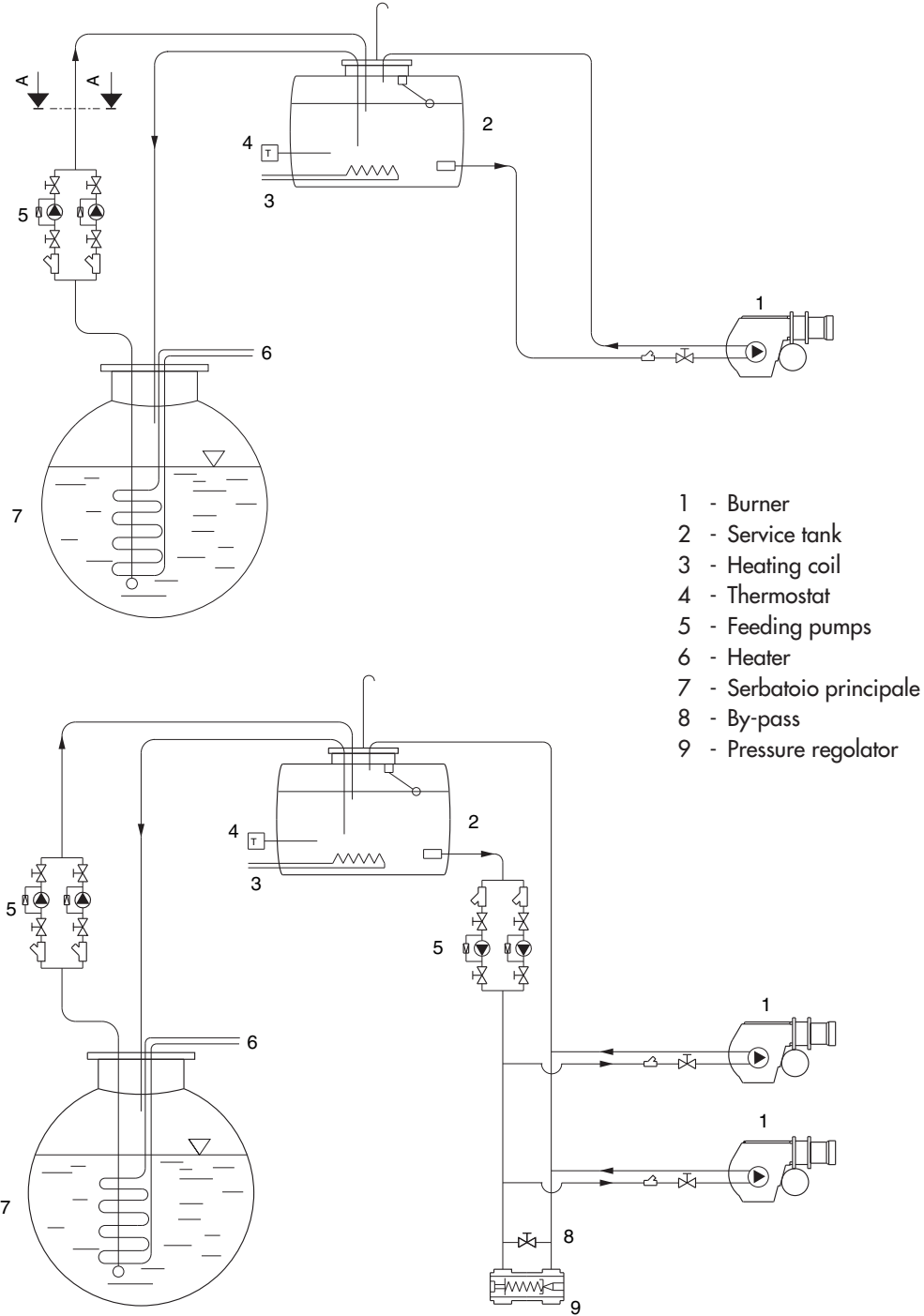

- 1 - Burner
- 2 - Service tank
- 3 - Heating coil
- 4 - Thermostat
- 5 - Feeding pumps
- 6 - Heater
- 7 - Serbatoio principale
- 8 - By-pass
- 9 - Pressure regulator

IMPORTANT: All feed piping are heated (see sec. A-A)

CHECKS TO BE MADE TO ENSURE A PROPER INSTALLATION

Before proceeding with the filling of the fuel system and subsequent burner start up, it is advisable to carry out the following checks:

- Power line must be adequate to system's adsorbed load
- Fuses must be adequate to the system's load
- Boiler's thermostats must have been properly connected
- Voltage and frequency must be within the specified limits
- Fuel type must be the one specified by the burner manufacturer
- Feed piping section must be adequate to the requested fuel flow rate
- Filters, cocks as well as fittings must have been properly installed
- Blast tube length must be the one specified by the boiler manufacturer
- Nozzle's flow rate of the burner must be adequate to boiler's output

BEFORE PROCEEDING WITH THE FILLING OF THE OIL SYSTEM, CHECK THE FOLLOWING POINTS

- Motor's direction of rotation (with 3phase version)
- There must be fuel in the tank.
- Fuel cocks must be open.
- Fuel return piping must be free from obstructions.

After having checked all the above items, proceed as follows:

- Connect a fuel pressure gauge.
- Disconnect the resistors power cable from the motor's remote control switch, and insulate it temporarily
- Unplug the safety box
- To press manually with a screwdriver on the pump motor's remote control switch, until the oil system is filled up(fig.5).

Note: the oil system can be considered filled when pressure gauge will show a constant reading.
When done, restore initial conditions.

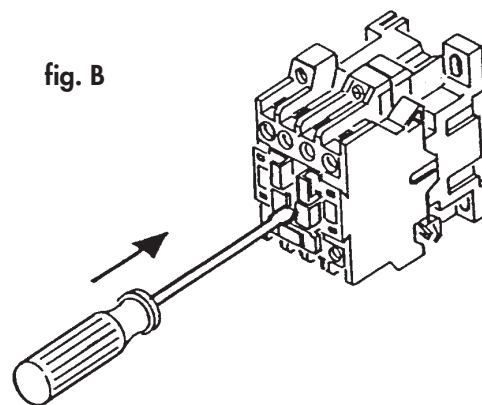

MODULATING OPERATION

With the burner in the start position and the appliance thermostats enabled, power is delivered to the resistances (G) of the preheater and heating cartridges for the pumps and the fuel supply line to the head (O). When the preheater thermostat reaches the set value, (usually a minimum of about 90°C is necessary to guarantee a good level of circulation) the pump start-up is enabled (set point on out 1, if using the GEFTRAN 200 thermoregulating device). If the preheating system of the tank is also equipped for a fluid exchanger (hot water, steam, diathermic oil) the thermostat may enable a contact in the terminal block for any stop-start of the fluid electrovalve. This is not a standard solution as the heated fluid is normally always connected. The pump starts to send oil (the head has already been heated by its cartridge (O) and therefore has no residue of cold dense oil) which flows from the tank to the head and then to the return line of the ring. When the head thermostat reaches the set value (usually about 70-30°C the cycle starts properly and the control programmer enables start-up. The servomotor sets itself at minimum (see chapter on regulation) acting on the air and fuel via the pressure regulator on the return.

The electromagnet (A) opens the nozzle (Q) in the following condition :

- sparks from the ignition electrodes are generated by the transformer also governed by the burner control device. If the cell fails to detect the flame the burner shuts down (with the cyclic control programmer cutting in). Once ignition has taken place and after the flame stabilisation period, the system starts operating in modulating mode.
- Before start-up make sure that the pump and delivery pipes are completely filled with hot fuel oil; the absence of fuel oil can cause pump seizure.
- If there is a block, a specific warning light on the programmer and on the burner front control board lights up and this signal is usually sent to the main control board of the equipment using the burner, setting off a buzzer and warning light.
- A few blocks are normal on first starting up (up to about 4); to release press the button on the programmer (also found on the front of the burner control board) for repeating the start cycle. Should they continue to occur seek the help of a specialised technician.

N.B. The position of the programmer at the time of the block is memorised to supply an indication of the cause of this block.

LANDIS LMO 44 CONTROL INFORMATION SYSTEM

In case of burner lockout, it is possible to read which cause originated it. Proceed as follows: with the burner in lockout mode (red LED switched on) keep pressed the lockout button for more than 3 sec. then release it. The red LED will blink according to the following error code list:

Error Code	Possible cause
2 blinks	No establishment of flame at the end of «TSA» - Faulty or soiled fuel valves - Faulty or soiled flame detector - Poor adjustment of burner, no fuel - Faulty ignition
3 blinks	Free
4 blinks	Extraneous light on burner start-up
5 blinks	Free
6 blinks	Free
7 blinks	Too many losses of flame during operation (limitation of the number of repetitions) - Faulty or soiled fuel valves - Faulty or soiled flame detector - Poor adjustment of burner
8 blinks	Time supervision oil pre-heater
9 blinks	Free
10 blinks	Wiring error or internal error, output contacts

OIL DELIVERY ADJUSTMENT

The diagram illustrates the fuel feeding system of these types of burners, which incorporates a by-pass nozzle with oil flow regulation on its return pipe. The oil supply is varied by acting on the nozzle through the pressure in the return line. Max. oil supply is therefore reached when the pressure in the pump line is about 30 bar and the return line is fully closed; min. oil supply when the return line is fully open. Relevant pressure readings in the return line are as follows:

Pump pressure 25-30 bar.

Max Burner output, return oil pressure :

FLUIDICS nozzle : 16 ÷ 19 bar.

BERGONZO nozzle : 20 ÷ 24 bar.

Min Burner output, return oil pressure :

FLUIDICS nozzle : 6 ÷ 9 bar

BERGONZO nozzle : 4 ÷ 8 bar

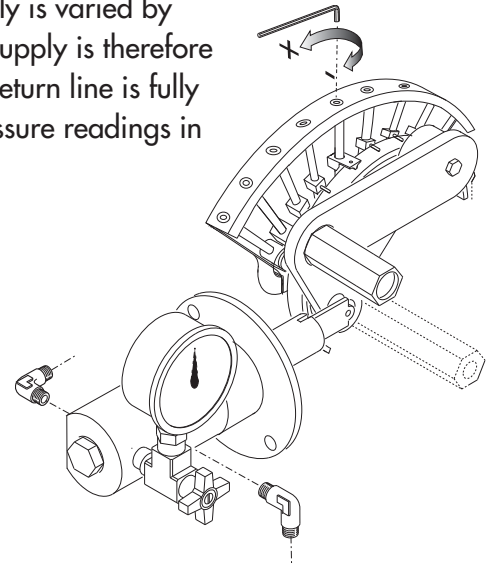

PREPURGING PHASE

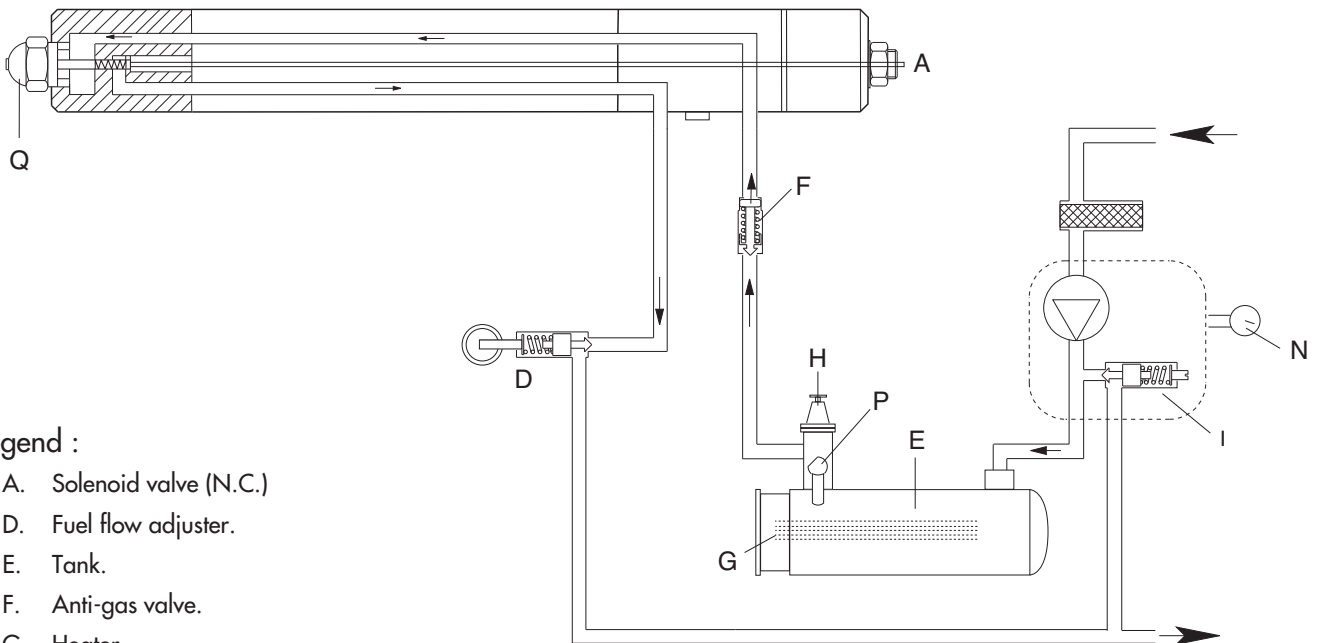

Legend :

- A. Solenoid valve (N.C.)
- D. Fuel flow adjuster.
- E. Tank.
- F. Anti-gas valve.
- G. Heater.
- H. Filter.
- I. Fuel pump.
- N. Manometer.
- P. Temperature probes
- Q. Nozzle.
- N.C. = Norm. closed

LANDIS & GYR SQM 50.481A2 AIR DAMPER SERVOMOTOR ADJUSTMENT



Remove cover to gain access to the adjusting cams. The cams are to be adjusted through the suitable key provided for. Description:

- I - Limit switch for air damper "High Flame" position adjustment (Max. power).
- II - Limit switch for ignition flame position adjustment.
- III - Limit switch for air damper "Low Flame" position adjustment (Min. power).
- IV - Limit switch "NOT USED".
- V - Limit switch "NOT USED".

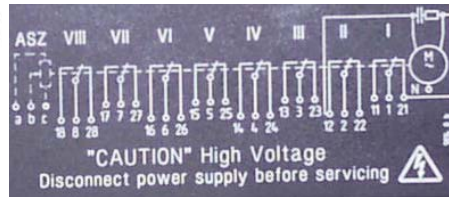

ADJUSTMENT OF FUEL THERMOSTATS

The working resistor thermostat must be set to 120 °C, while the safety one to 160 °C. Said adjustments can be slightly modified following the type of fuel and particular uses.

- A - Safety thermostat (160° C).
- B - Working thermostat (120° C).
- C - Levelling thermostat (130° C).
- D - Heavy oil min. temp. thermostat (90° C).

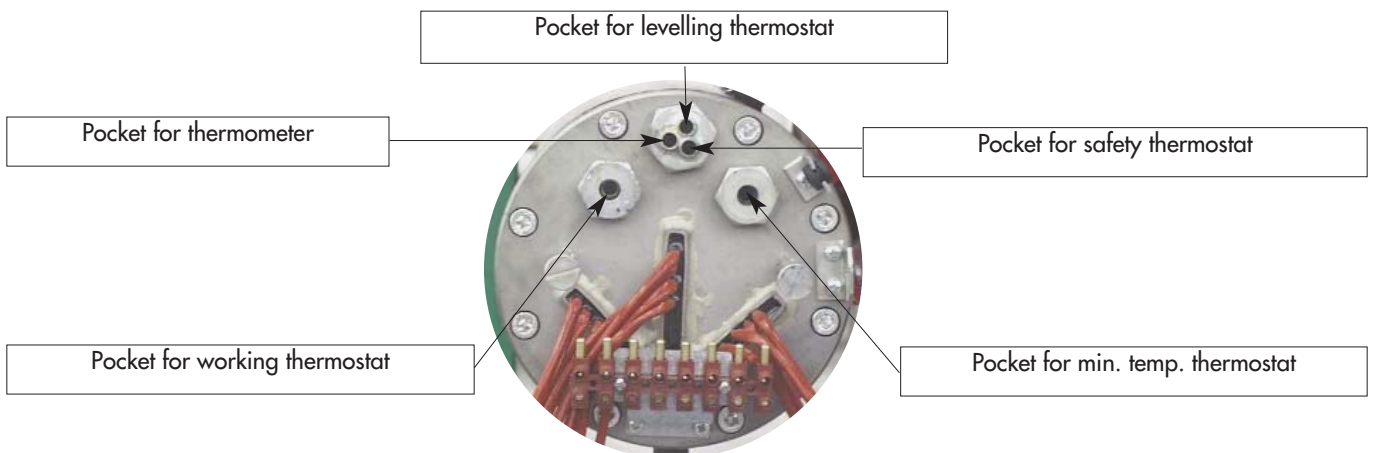
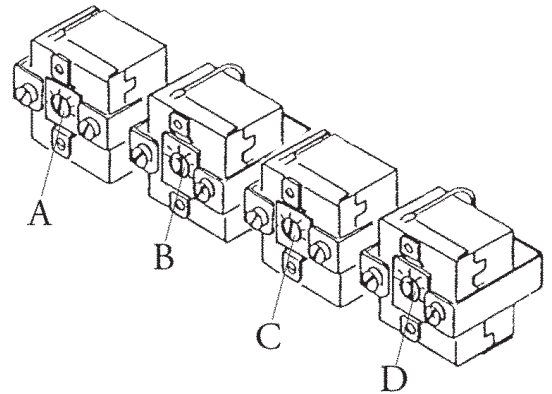

POSITION OF IGNITION ELECTRODES

For a correct burner ignition, carefully respect the dimensions shown by the picture.

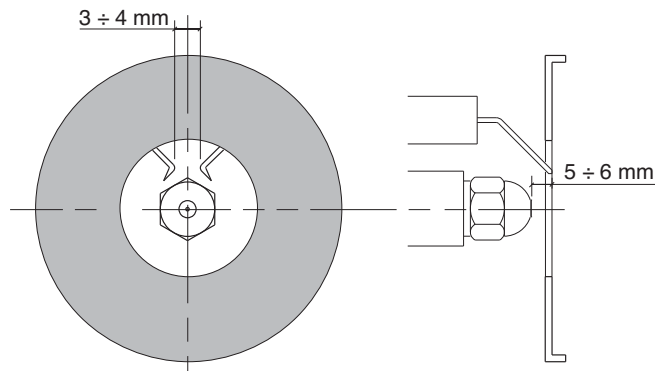

CLEANING AND MAINTENANCE OF FILTERS MOUNTED ON THE PREHEATER

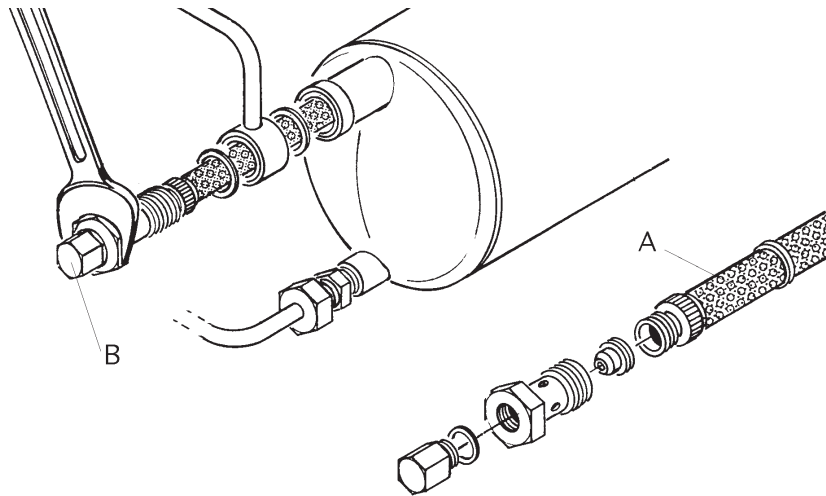

REMOVING OF THE FILTER

1. Switch-off the burner.
 2. Loosen screw B and drain part of the fuel from the heater, until the fuel level drop below the filter.
 3. Unscrew and pull out the stem filter A from its seat.
 4. Clean the filter and reassemble the parts as shown by the picture, then fit it in its own seat.
- It is advisable to replace all filter and valve gaskets whenever they are removed.

Note that when the burner is working the heater has a pressure of abt. 23 bar, and that it becomes very dangerous to carry out said operations with the burner running.

TROUBLESHOOTING

- 1 - The burner does not start**
 - Power switch in OFF position
 - Fuses burnt
 - Boiler's thermostats open
 - Resistors failure
 - Heater thermostats open

- 2 - The resistors heat but the burner does not start**
 - Thermostats failure
 - Power switch in OFF position
 - Heater thermostats open
 - Control box failure

- 3 - The burners runs the prepurging and switches to lock out**
 - Power switch in OFF position
 - Control box failure
 - Photoresistor failure
 - Premature ignition due to oil leakage from solenoid valve

- 4 - The burner does not ignite during cycle and switches to lock out**
 - Control box failure

- 5 - The burner does not ignite**
 - Ignition electrodes dirty
 - Electrodes failure
 - Electrodes installed in wrong position
 - Ignition transformer's failure
 - 1st Stage valve's failure
 - Nozzles clogged
 - Eccles of combustion air related to nozzles flow rate
 - Control box failure

- 6 - The burner ignite but switches to lock out**
 - The oil temperature is too low (flame jumps)
 - Nozzles are too worn
 - The photoresistor does not detect the flame
 - The oil pressure during prepurging is too low
 - Eccles of combustion air related to nozzles flow rate
 - Control box failure
 - Oil pressure too low
 - Filters clogged

- 7 - The burner does not switches to High Flame**
 - Manual switch in I position (Low Flame)
 - 2nd Stage coil failure
 - Oil pressure too low
 - Filters clogged
 - 2nd stage nozzle worn or clogged
 - Control box failure

- 8 - Oil pressure too low or irregular**
 - Pump and/or heater filters clogged
 - The norm. open valve does not close
 - Irregular oil feed
 - Pump failure

Index**1 - Caracteristiques techniques**

- Caracteristiques techniquesp.25
- Plage de travailp.25
- Dimensions d'encombrementp.26

2 - Installation

- Installation du brûleurp.26
- Alimentation du fioul lourdp.26
- Diagramme pression pompe/temperature fioulp.27
- Schema alimentation du fioul lourdp.28

3 - Démarreur et régléments

- Vérificationsp.29
- Fonctionnement du brûleurp.30,31
- Circuit hydrauliquep.31
- Réglémentsp.32

4 - Entretien d'utiliser-et

- Nettoyage et entretienp.33
- Anomalies de fonctionnementp.34

CARACTERISTIQUES TECHNIQUES

MODELES		OILFLAM 50.1	OILFLAM 80.1	OILFLAM 120.1	OILFLAM 170.1	OILFLAM 200.1
Puissance thermique max.	kcal/h	500.000	800.000	1.200.000	1.462.000	1.800.000
	kW	581	930	1395	1700	2093
Puissance thermique min.	kcal/h	250.000	400.000	588.000	588.000	588.000
	kW	290	464	682	682	682
Débit fioul lourd max.	kg/h	51	82	122	148	184
Débit fioul lourd min.	kg/h	25,5	41	60	60	60
Viscosité max.		15°E à 50°C				
	version D	50°E à 50°C				
Tension d'alimentation	50 Hz V	230/400	230/400	230/400	230/400	230/400
Puissance moteur	kW	1,5	1,5	2,2	3	4
Tours par minute	N°	2.800	2.800	2.800	2.800	2.800
Transformateur	kV/mA	13/35	13/35	13/35	13/35	13/35
Résistances de travail	W	3 x 550	3 x 800	3 x 1350	3 x 1650	3 x 2000
Résistances de nivellement	W	3 x 450	3 x 750	3 x 1000	3 x 1350	3 x 1500
Coffret de sécurité	LANDIS	LMO 44	LMO 44	LMO 44	LMO 44	LMO 44
Combustible : fioul lourd		kcal/kg 9.800				

PLAGE DE TRAVAIL

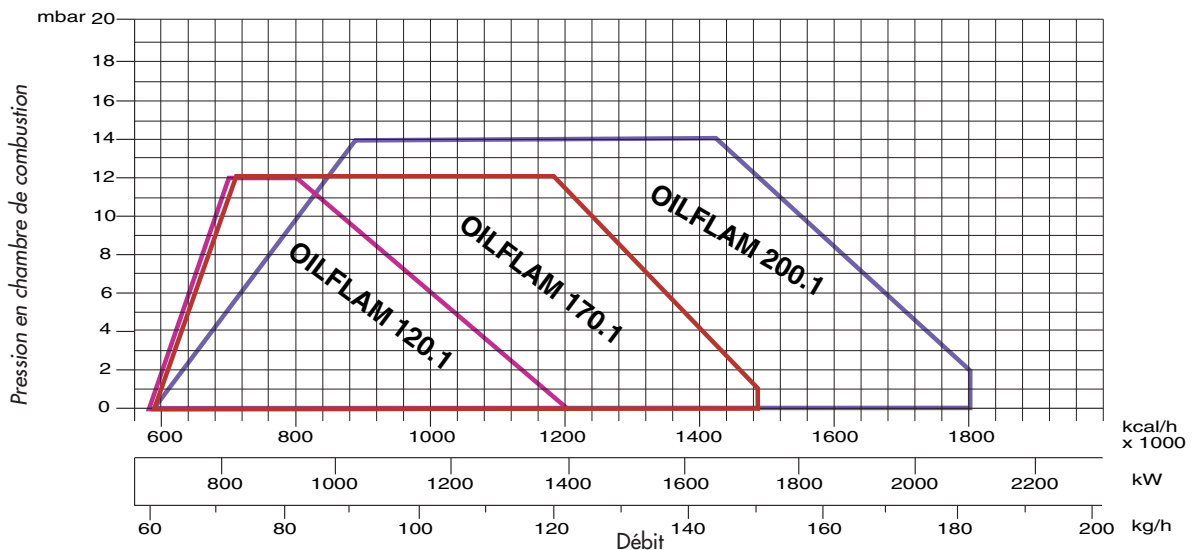
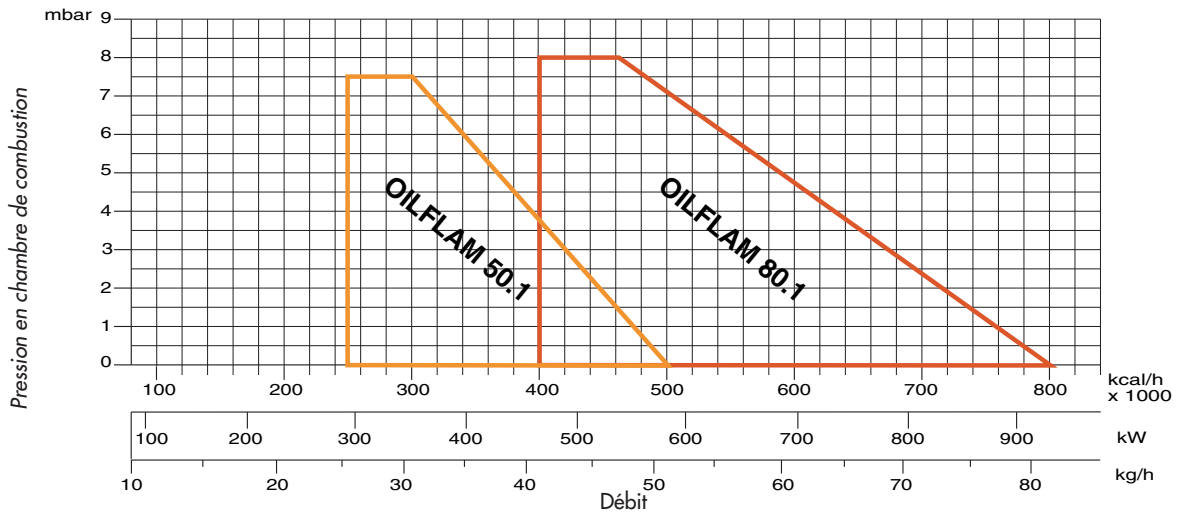

DIMENSIONS D'ENCOMBREMENT (mm)

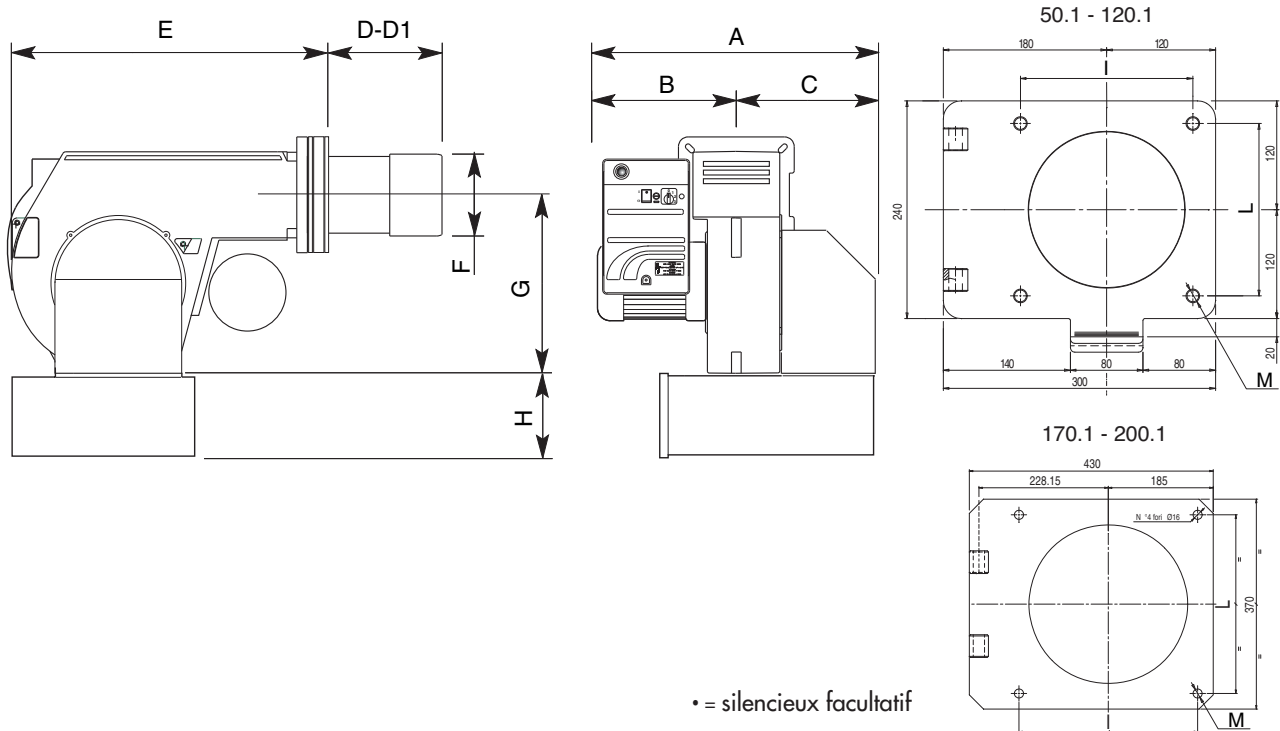

* = silencieux facultatif

MODELE	A	B	C	D	D1	E	F	G	H	I	L	M
OILFLAM 50.1 PR	815	370	445	170	310	600	190	376	215●	190	190	M10
OILFLAM 80.1 PR	815	370	445	170	310	600	190	376	215●	190	190	M10
OILFLAM 120.1 PR	815	370	445	170	310	600	190	376	215●	190	190	M10
OILFLAM 170.1 PR	850	400	450	295	455	710	250	398	283●	315	315	M14
OILFLAM 200.1 PR	850	400	450	295	455	710	270	398	283●	315	315	M14

D = tête courte D1 = tête longue

INSTALLATION DU BRULEUR

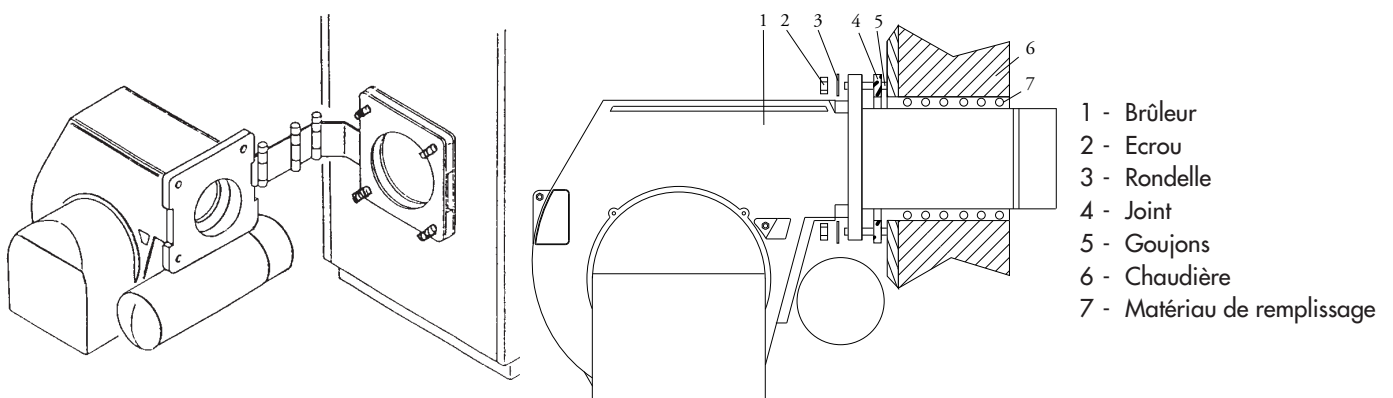

ALIMENTATION DU FIOUL LOURD



DIAGRAMME PRESSION POMPE / TEMPERATURE FIOUL

La gazéification de fractions volatiles dans le fioul lourd réchauffé s'avère être la cause principale d'usure prématurée de la pompe d'alimentation. Pour éviter cet inconvénient, réguler la pression de la pompe suivant le diagramme en bas.

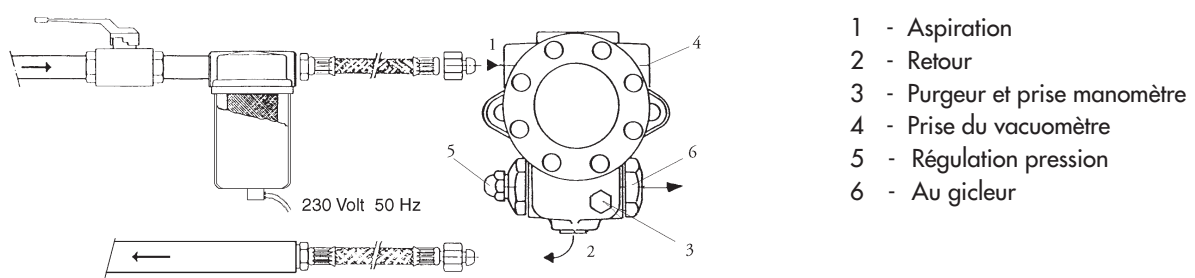
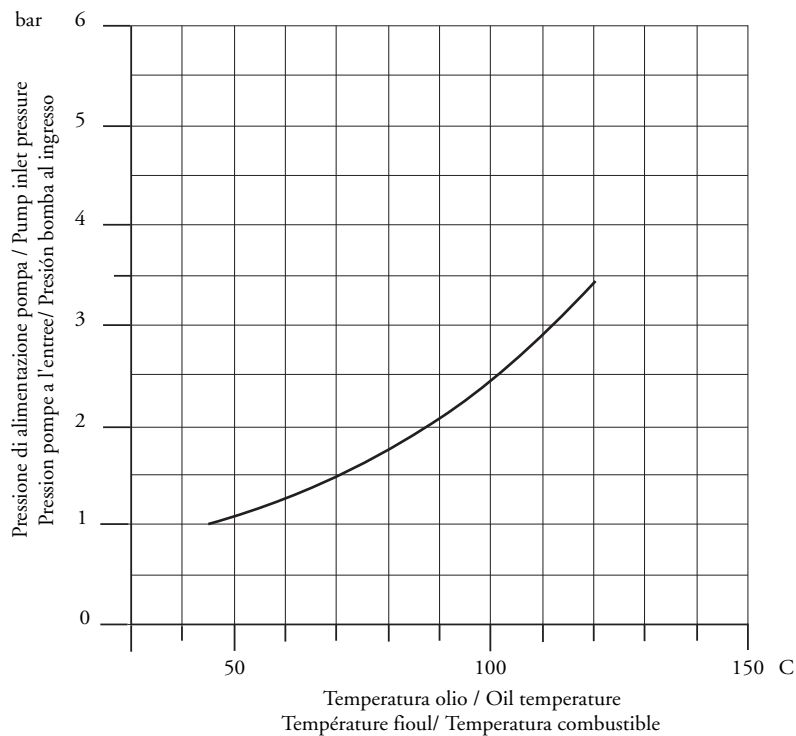

ATTENTION: Pour un correct fonctionnement de la pompe, vérifier les données suivants :

Pompe :	SUNTEC E..NC 1069
Température du fioul à la pompe:	Max. 120 °C
Pressions maximales admissibles:	Max. 3,5 bar en entrée.

SCHEMA ALIMENTATION DU FIOUL LOURD JUSQU'À 50°E À 50°C

Coupe. A - A

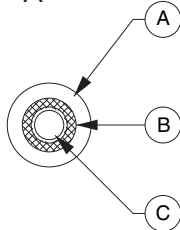

Légende

- A - gaine isolante
- B - Résistance électrique
- C - Tuyau alim. fuel.

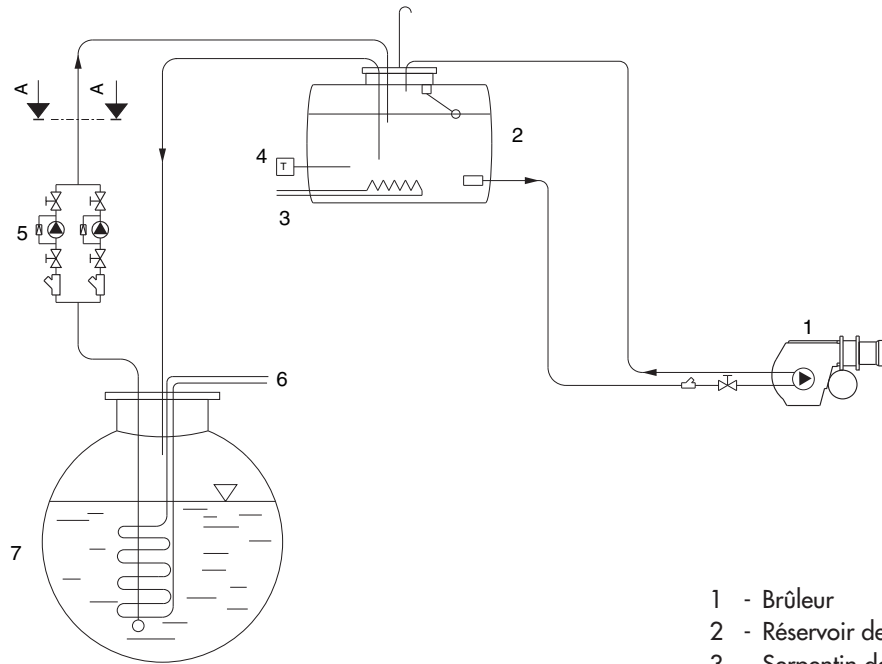

- 1 - Brûleur
- 2 - Réservoir de service
- 3 - Serpentin de rech.
- 4 - Thermostat
- 5 - Pompes de chargement
- 6 - Réchauffeur
- 7 - Réservoir principal
- 8 - By-pass
- 9 - Régulateur

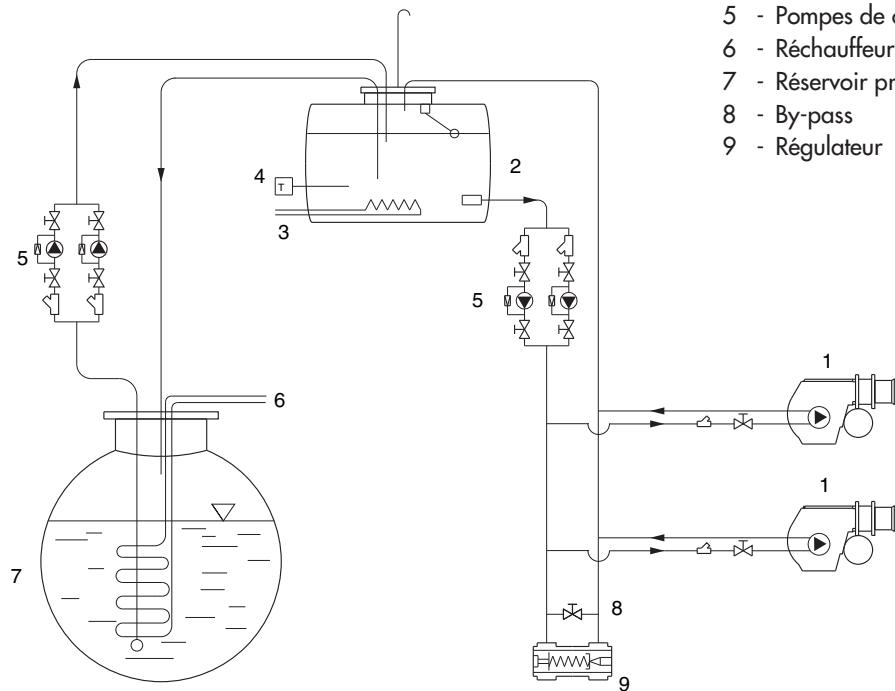

IMPORTANT: Tous les tuyaux d'alimentation sont réchauffés (voir à la coupe A-A)

VERIFICATIONS A EFFECTUER POUR UNE INSTALLATION CORRECTE

Avant de procéder au remplissage du circuit d'alimentation et relative mise en service du brûleur, il serait souhaitable d'effectuer les contrôles suivants:

- La ligne d'alimentation doit être adéquate à la charge absorbée par l'installation
- Les fusibles doivent être à la charge absorbée par l'installation
- Les thermostats de la chaudière doivent avoir été connectés correctement
- Voltage et fréquence doivent être compris dans les limites spécifiés
- Le type de fuel doit être celui spécifié par le constructeur du brûleur
- La section de la tuyauterie d'alimentation doit être adéquate à la portée de fuel requise
- Les filtres, robinets et raccords doivent avoir été dûment installés
- La longueur du gueulard doit être celle spécifiée par le constructeur de la chaudière
- La portée des gicleurs du brûleur doit être adéquate à la puissance de la chaudière

**AVANT DE PROCEDER AU REMPLISSAGE DU CIRCUIT FUEL LOURD EFFECTUER
LES CONTROLES SUIVANTS**

- Contrôler le sens de rotation du moteur (dans la version triphasée)
- Vérifier la présence de combustible dans le réservoir
- Vérifier que les robinets soient ouverts
- Vérifier que le retour du combustible dans le réservoir soit sans occlusions

Après avoir vérifié les points susdits, procéder de la manière suivante:

- Connecter un manomètre de contrôle de la pression du combustible
- Agir manuellement sur le télérupteur de le moteur pompe avec un tournevis, jusqu'à obtenir le remplissage du circuit (fig.5).

Note: le circuit sera remplis lorsque le manomètre indiquera une pression constante. Une fois remplis le circuit, et rétablir les condition initiales.

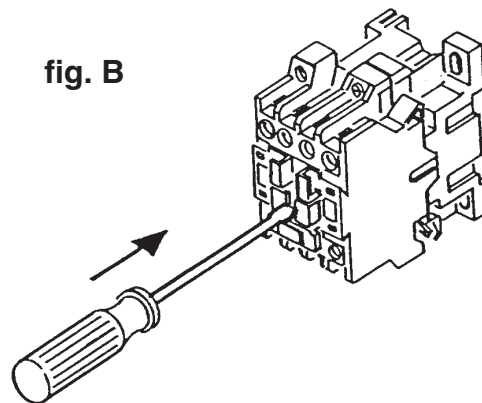

FR

FONCTIONNEMENT DU BRÛLEUR

Quand le brûleur est en position démarrage et que les thermostats chaudière sont enclenchés, les résistances (G) du réchauffeur, les résistances auxiliaires sur pompe et le groupe tête sont sous tension. Quand le thermostat du réchauffeur atteint la valeur fixée (normalement, il faut au minimum 90°C pour garantir un niveau de circulation adéquat), la pompe de démarrage est autorisée (si l'on utilise le thermorégulateur GEFAN 200, régler le point de consigne de la sortie 1).

Si le système de préchauffage du réservoir est également prévu pour l'emploi d'un échangeur de liquides (eau chaude, vapeur, huile diathermique), le thermostat peut activer un contact du bornier pour donner l'autorisation électrique à l'électrovanne liquides. Ceci n'est pas une solution standard car, normalement, le fluide chauffé est toujours en circulation.

La pompe commence à envoyer le fuel lourd (la tête a déjà été chauffée par sa résistance (O), c'est pourquoi il n'y a pas de résidus de fuel lourd dense froid) qui circule du réservoir à la tête, puis à la ligne de retour de la boucle d'alimentation du fuel lourd. Quand le thermostat de la tête atteint la valeur fixée (normalement, le cycle débute de manière appropriée autour de 70-30°C), l'appareil donne l'autorisation à l'allumage du brûleur. Le servomoteur se positionne automatiquement sur le minimum (voir le chapitre de la régulation) en agissant sur la vanne de l'air et en agissant sur le retour du régulateur de pression du fuel lourd.

L'électroaimant (A) ouvre le gicleur (Q) dans la condition suivante :

- les étincelles des électrodes d'allumage sont générées par le transformateur, qui est également réglé automatiquement par le dispositif de contrôle du brûleur.

Si la cellule de détection ne détecte pas la flamme, cela provoque le blocage du brûleur.

Une fois l'allumage effectué et la période de stabilisation de la flamme écoulée, le système commence à fonctionner en modulation.

- Avant l'allumage, s'assurer que la pompe et les tubes de refoulement sont complètement remplis avec le fuel lourd chaud ; l'absence de fuel lourd peut provoquer le grippage de la pompe.

- En cas de blocage, un voyant s'allume sur le panneau de commande du brûleur ; de plus, un signal de tension est disponible pour la transmission de l'alarme à distance.

- Lors du premier allumage, il est normal que des blocages surviennent (jusqu'à 4 environ) ; pour réarmer, appuyer sur le bouton de l'appareil (qui se trouve dans la partie antérieure du panneau de contrôle du brûleur) afin de répéter le cycle de démarrage. Si les blocages persistent, s'adresser à un technicien qualifié.

N.B. : La condition de l'appareil au moment du blocage peut fournir des indications sur la cause du blocage.

SEULEMENT POUR LES COFFRETS DE SECURITE LANDIS LMO 44

En cas de mise en sécurité du brûleur on pourra lire la cause qui l'a provoqué. Dans ce cas, procéder comme il suit: avec le brûleur en sécurité (LED rouge allumé) appuyer sur le bouton de réarmement pendant plus de trois secondes et le relâcher. Le LED rouge commencera à clignoter suivant la liste de codes-erreur ci-dessous:

Code-erreur	Cause possible
2 clignotements défectueuses	Absence de flamme à la fin du temps de sécurité à l'allumage «TSA» - électrovannes défectueuses - détecteur de flamme défectueux - réglage brûleur erroné - électrodes
3 clignotements	Non utilisé
4 clignotements	Signal de présence flamme pendant la phase de préventilation
5 clignotements	Non utilisé
6 clignotements	Non utilisé
7 clignotements	Extinctions trop fréquentes de la flamme pendant le fonctionnement (limite de n° de répétitions du cycle dépassée) - électrovannes défectueuses - détecteur de flamme défectueux - réglage brûleur erroné
8 clignotements	Contrôle du temps chauffage combustible
9 clignotements	Non utilisé
10 clignotements	Contacts en sortie défectueux ou panne du dispositif interne

RÉGLAGE DE LA PRESSION DE RETOUR FUEL LOURD

Le diagramme représente le système de réglage du retour de fuel lourd pour ces types de brûleurs, qui incorporent un gicleur avec retour variable progressif. Le débit du fuel lourd peut être modifié au moyen du gicleur de retour en modifiant la pression dans le retour. On obtient le débit maximum de fuel lourd quand la pression de la pompe est d'environ 30 bars et que le retour est complètement fermé. On obtient le débit minimum du fuel lourd quand la ligne de retour est complètement ouverte. Pour mesurer la pression en refoulement, monter un manomètre sur la pompe. La pression du retour peut être lue sur le manomètre, monté sur le régulateur de pression, qui équipe le brûleur.

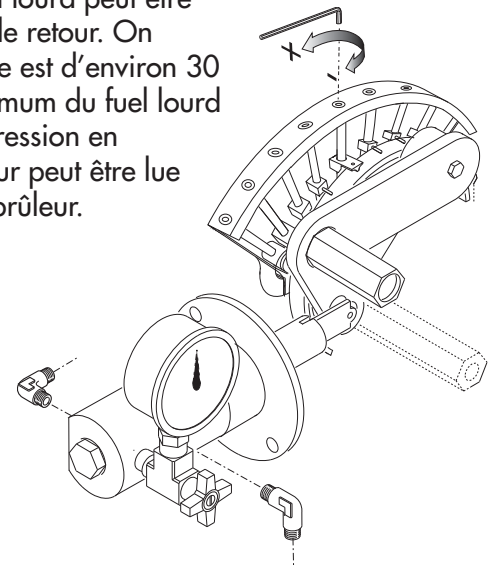

Pression pompe 25-30 bar.

Débit max. brûleur, pression de retour :

Gicleur FLUIDICS : 16 ÷ 19 bar.

Gicleur BERGONZO : 20 ÷ 24 bar.

Débit min. brûleur, pression de retour:

Gicleur FLUIDICS : 6 ÷ 9 bar

Gicleur BERGONZO : 4 ÷ 8 bar

PHASE DE PREBALAYAGE

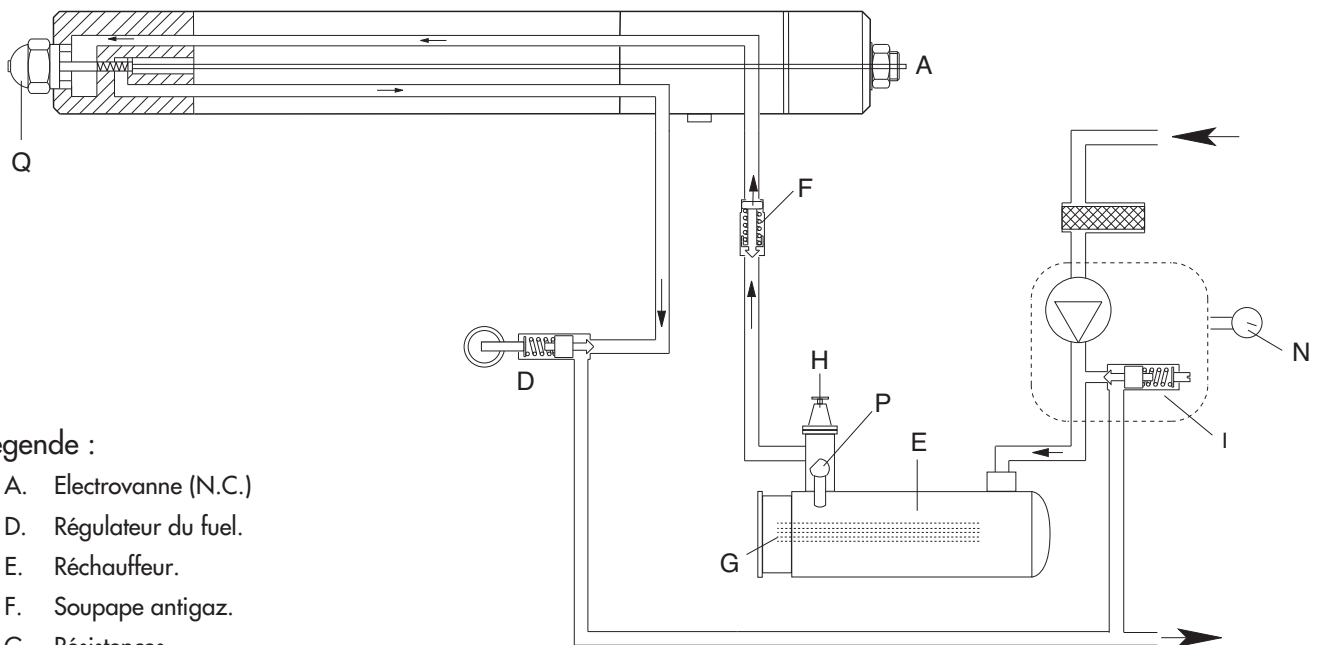

Légende :

- A. Electrovanne (N.C.)
- D. Régulateur du fuel.
- E. Réchauffeur.
- F. Soupape antigaz.
- G. Résistances.
- H. Filtre.
- I. Pompe combustible.
- N. Manomètre.
- P. Sondes de la température
- Q. Gicleur.
- N.C. = Norm. fermée

FR

REGULATION SERVOMOTEUR DU CLAPET DE L'AIR LANDIS & GYR SQM 50.481A2



Enlever le couvercle pour avoir accès aux cames de régulation. La régulation des cames doit être faite à l'aide de la clé en dotation.

- I - Came de régulation de la position d'ouverture en grande Allure.
- II - Came de régulation de l'air en allumage.
- III - Came de régulation de la position d'ouverture en petite Allure.
- IV - Came de régulation libre (non utilisé).
- V - Came de régulation libre (non utilisé).

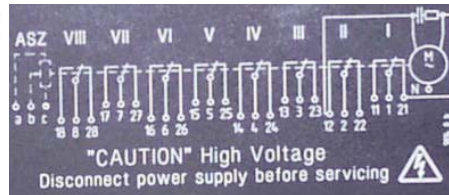

REGULATION THERMOSTATS FIOUL LOURD

Le thermostat de travail des résistances doit être réglé autour de 120 °C et le thermostat de sécurité à 160 °C. Ces régulations peuvent être légèrement modifiées en fonction du type de combustible et d'applications particulières.

- A - Thermostat de sécurité (160° C).
- B - thermostat de travail (120° C).
- C - Thermostat de nivellement (130° C).
- D - Thermostat de température minimale du fioul lourd (90° C).

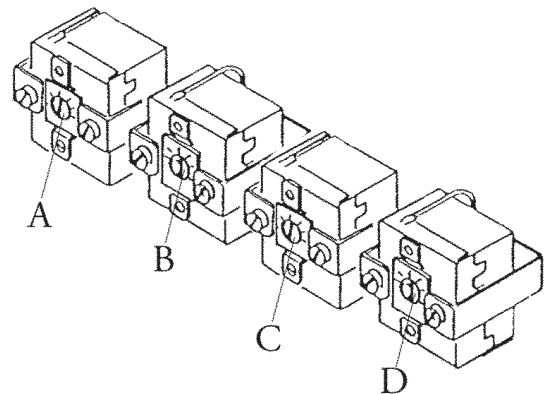

Doit de gant pour thermostat de nivellement

Doit de gant pour thermomètre

Doit de gant pour thermostat de sécurité

Doit de gant pour thermostat de travail

Doit de gant pour thermostat de température minimale

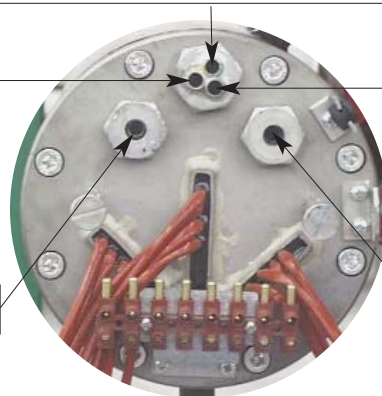

POSITION DES ELECTRODES D'ALLUMAGE

Pour un allumage correct du brûleur, veiller à que les distances spécifiées dans l'illustration soient respectées.

FR

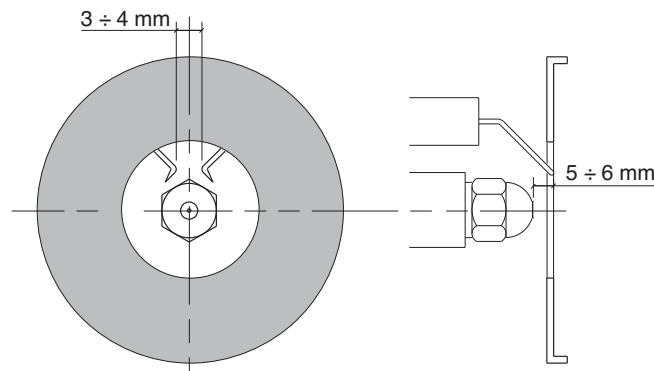

NETTOYAGE ET ENTRETIEN DES FILTRES MONTES DANS LE RECHAUFFEUR

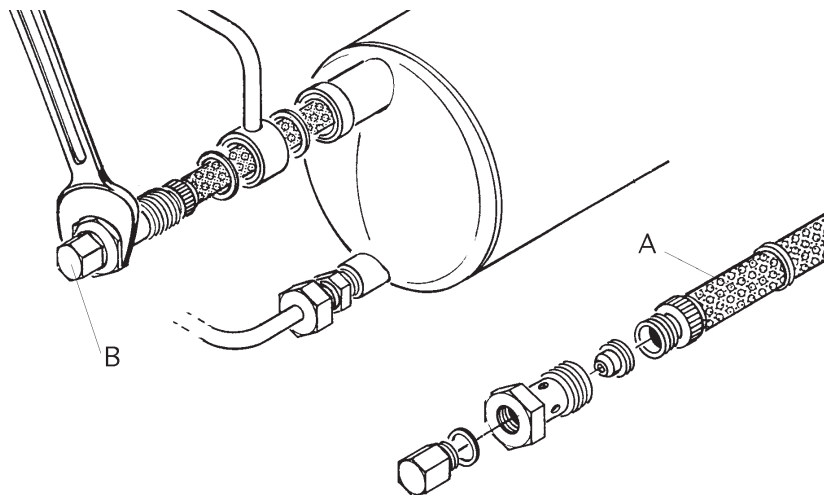

EXTRACTION DU FILTRE

1. Eteindre le brûleur
2. Dévisser la vis B et décharger une partie d'huile contenue à l'intérieur du réchauffeur, de façon à ce que le niveau du liquide descende au-dessous du filtre
3. Dévisser et extraire la tige du filtre A de son siège
4. Après avoir nettoyé le filtre, remonter les parties suivant l'illustration et le réintroduire dans son siège

Il serait souhaitable de remplacer toutes les joints du filtre et de la vanne chaque fois que ces derniers sont démontés.

On rappelle que, lorsque le brûleur est en fonction, dans le réchauffeur il y a une pression d'env. 23 bar et que, par conséquent devient très dangereux effectuer des opérations susdites avec le brûleur en marche.

ANOMALIES DE FONCTIONNEMENT

- 1 - Le brûleur ne démarre pas**
 - Interrupteur d'alimentation sur OFF
 - Fusibles brûlés
 - Thermostats chaudière ouverts
 - Résistances en panne
 - Thermostats réchauffeur ouverts

- 2 - Les résistances chauffent mais le brûleur ne démarre pas:**
 - Thermostats en panne
 - Interrupteur sur OFF
 - Thermostats du réchauffeur ouverts
 - Coffret de sécurité en panne

- 3 - Le brûleur effectue le prebalayage mais se met en sécurité:**
 - Interrupteur sur OFF
 - Coffret de sécurité en panne
 - Photorésistance en panne
 - Amorçage prématuré de la flamme suite à une fuite de fuel par l'électrovanne

- 4 - Le brûleur ne s'allume pas pendant le cycle, puis se met en sécurité:**
 - Coffret de sécurité en panne

- 5 - Le brûleur ne s'allume pas:**
 - Electrodes sales
 - Electrodes cassés
 - Electrodes mal positionnés
 - Transformateur d'allumage en panne
 - Vanne de 1^e Allure en panne
 - Gicleurs bouchés
 - Excès d'air comburant par rapport aux gicleurs
 - Coffret de sécurité en panne

- 6 - Le brûleur s'allume mais se met en sécurité:**
 - Température du fuel trop faible (flamme irrégulière)
 - Usure excessive des gicleurs
 - La photorésistance ne perçoit pas la flamme
 - Pression du fuel trop faible pendant le prébalayage
 - Excès d'air comburant par rapport aux gicleurs
 - Coffret de sécurité en panne
 - Pression fuel trop faible
 - Filtres bouchés

- 7 - Le brûleur ne passe pas à la 2^e Allure:**
 - Interrupteur manuel sur I (1^e Allure)
 - Bobine de 2^e Allure en panne
 - Pression fuel trop faible
 - Filtres bouchés
 - Gicleur de 2^e Allure trop usé ou bouché
 - Coffret de sécurité en panne

- 8 - Pression du fuel trop faible ou irrégulière:**
 - Filtres pompe et/ou réchauffeur bouchés
 - L'électrovanne norm. ouverte ne se ferme pas
 - Alimentation fuel irrégulière
 - Pompe en panne

Índice

ES

1 - Características técnicas

- Características técnicasp.36
- Campo de trabajop.36
- Dimensiones globalesp.37

2 - Instalación

- Instalación del quemadorp.37
- Alimentación fuel pesadop.37
- Diagrama presión de la bomba/temperatura combustiblep.38
- Esquema alimentación fuel pesadop.39

3 - Arrancador y regulaciones

- Verificacionesp.40
- Funcionamiento del quemadorp.41,42
- Sistema hidráulicop.42
- Regulacionesp.43

4 - Uso y mantenimiento

- Limpieza y mantenimientop.44
- Anomalías de funcionamientop.45

CARACTERÍSTICAS TÉCNICAS

ES

MODELOS		OILFLAM 50.1	OILFLAM 80.1	OILFLAM 120.1	OILFLAM 170.1	OILFLAM 200.1
Potencia térmica máx.	kcal/h	500.000	800.000	1.200.000	1.462.000	1.800.000
	kW	581	930	1395	1700	2093
Potencia térmica mín.	kcal/h	250.000	400.000	588.000	588.000	588.000
	kW	290	464	682	682	682
Caudal fuel máx.	kg/h	51	82	122	148	184
Caudal fuel mín.	kg/h	25,5	41	60	60	60
Viscosidad máx.		15°E a 50°C				
	version D	50°E a 50°C				
Alimentación eléctrica	50 Hz V	230/400	230/400	230/400	230/400	230/400
Potencia del motor	kW	1,5	1,5	2,2	3	4
Revol. por minuto	Nº	2.800	2.800	2.800	2.800	2.800
Transformador de encendido	kV/mA	13/35	13/35	13/35	13/35	13/35
Resistencia de trabajo	W	3 x 550	3 x 800	3 x 1350	3 x 1650	3 x 2000
Resistencia de nivelación	W	3 x 450	3 x 750	3 x 1000	3 x 1350	3 x 1500
Equipo de control de la llama	LANDIS	LMO 44	LMO 44	LMO 44	LMO 44	LMO 44
Aceite pesado (fuel)		kcal/kg 9.800				

CAMPO DE TRABAJO

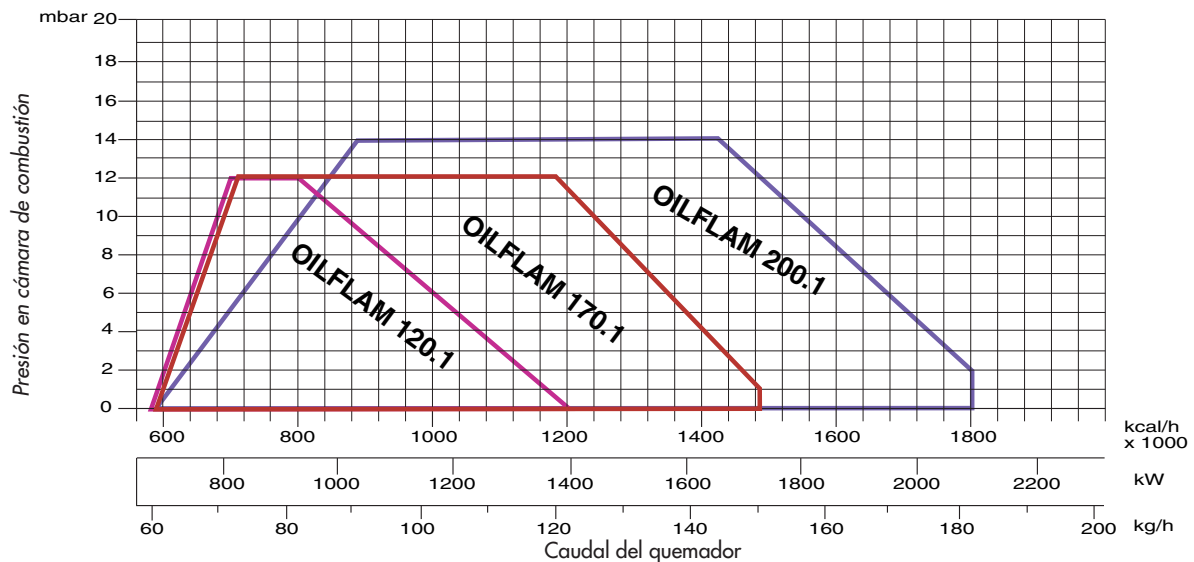
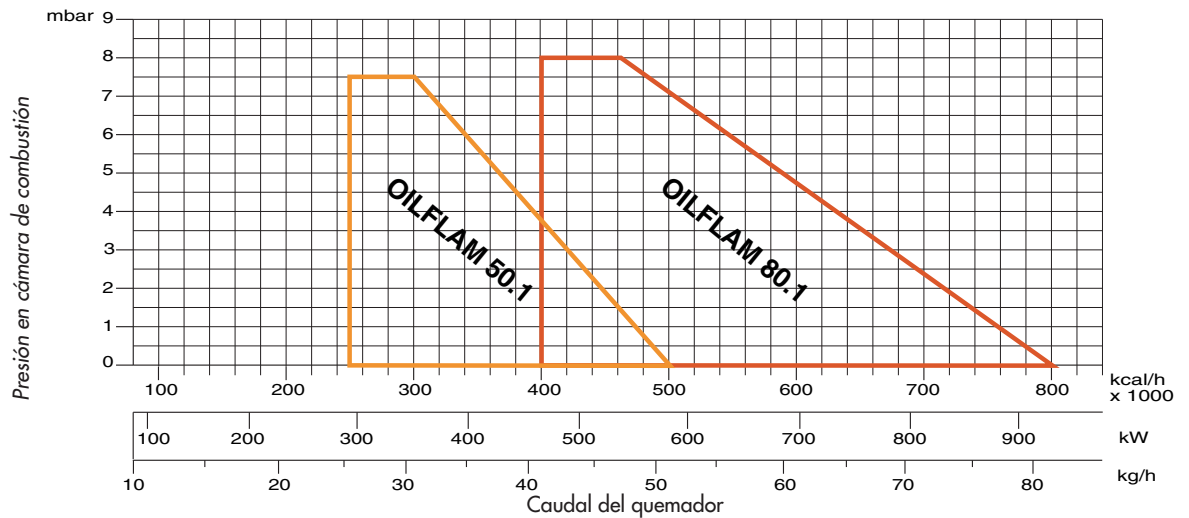

DIMENSIONES GLOBALES (mm)

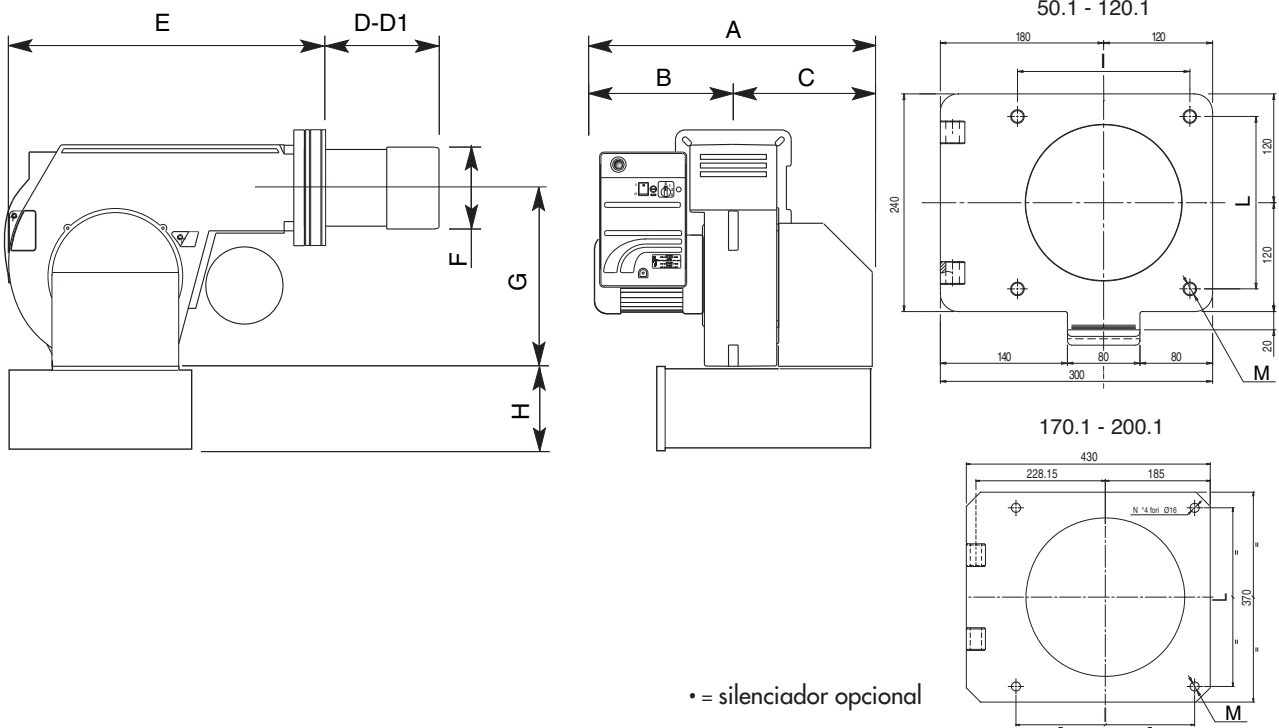

MODELOS	A	B	C	D	D1	E	F	G	H	I	L	M
OILFLAM 50.1 PR	815	370	445	170	310	600	190	376	215●	190	190	M10
OILFLAM 80.1 PR	815	370	445	170	310	600	190	376	215●	190	190	M10
OILFLAM 120.1 PR	815	370	445	170	310	600	190	376	215●	190	190	M10
OILFLAM 170.1 PR	850	400	450	295	455	710	250	398	283●	315	315	M14
OILFLAM 200.1 PR	850	400	450	295	455	710	270	398	283●	315	315	M14

D = cabeza corta D1 = cabeza larga

INSTALACIÓN DEL QUEMADOR

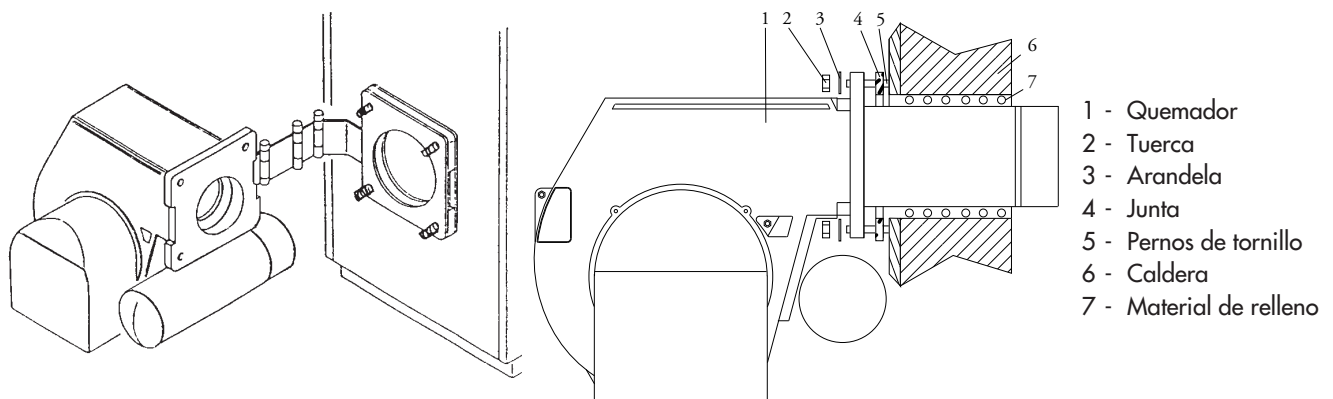

ALIMENTACIÓN FUEL PESADO



DIAGRAMA PRESIÓN DE LA BOMBA / TEMPERATURA COMBUSTIBLE

ES

La gasificación de fracciones volátiles en el fuel pesado precalentado, resulta ser la causa principal del desgaste prematuro de la bomba de alimentación. Para evitar este problema, regular la presión de la bomba según el diagrama abajo.

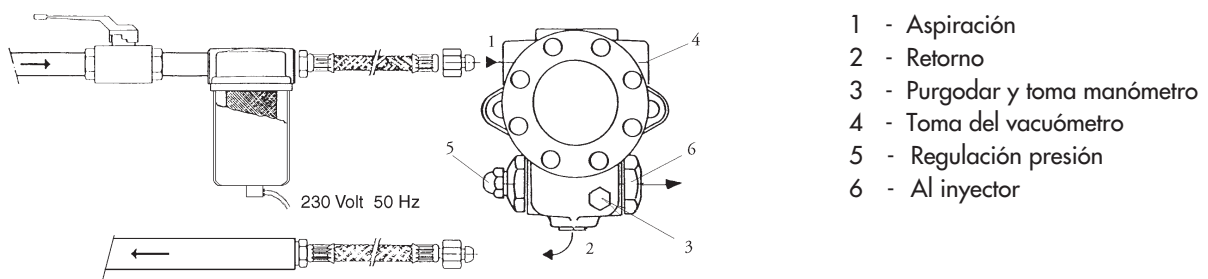
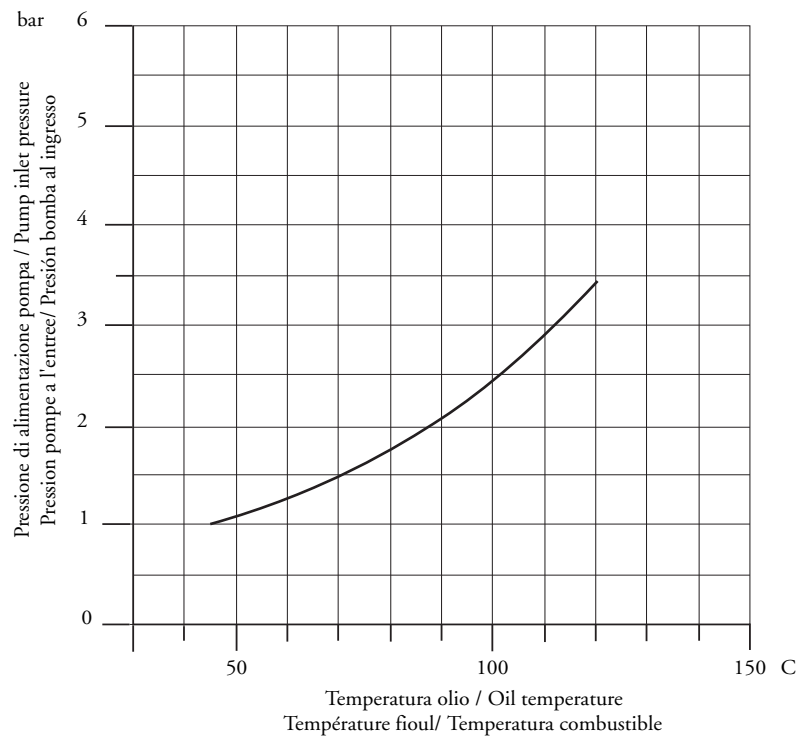

CUIDADO: Para un correcto funcionamiento de la bomba, comprobar los datos siguientes:

Bomba :

SUNTEC E..NC 1069

Temperatura máxima del fuel pesado a la bomba: Max. 120 °C

Presiones máximas admisibles: Máx. 3,5 bar en ingreso.

ESQUEMA ALIMENTACIÓN FUEL PESADO HASTA A 50°C A 50°C

Sección. A - A

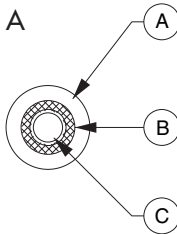

Leyenda

- A - camisa aislante
- B - Resistencia eléctrica
- C - Tubo alim. combust.

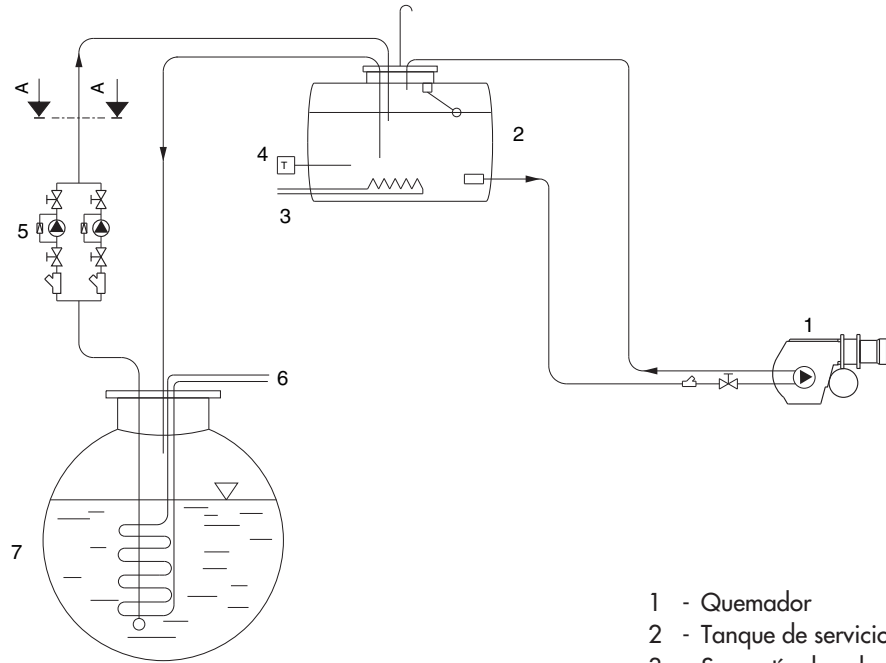

- 1 - Quemador
- 2 - Tanque de servicio
- 3 - Serpentin de calentamiento
- 4 - Termostato
- 5 - Bombas de aliment.
- 6 - Calentador
- 7 - Tanque principal
- 8 - By-pass
- 9 - Regulador

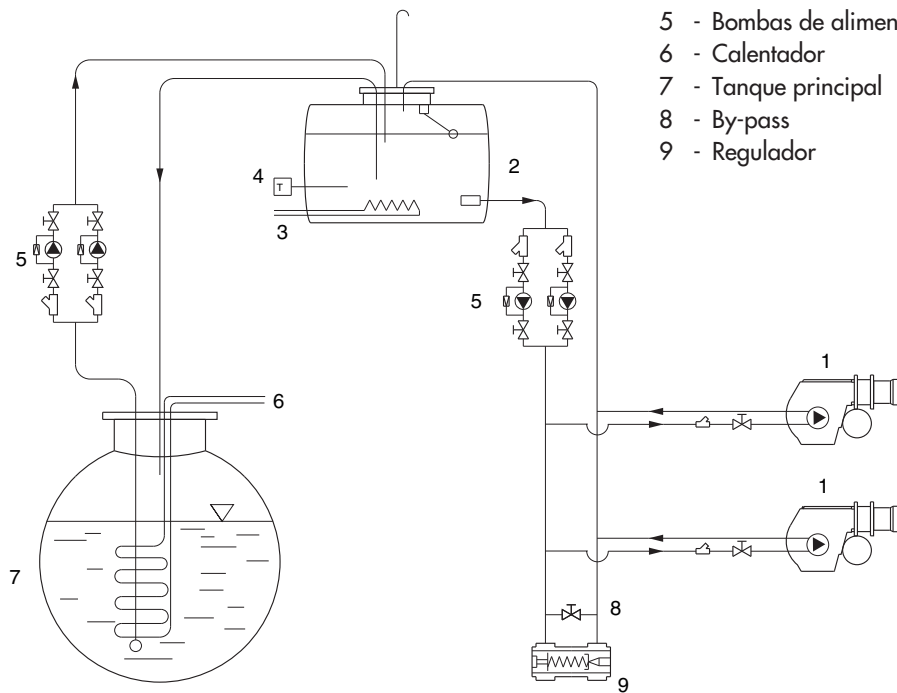

IMPORTANTE: Toda la tubería de alimentación es calentada (ver a la secc. A-A)

COMPROBACIONES A EFECTUAR PARA UNA CORRECTA INSTALACIÓN:

ES

Antes de proceder con el relleno del circuito de alimentación y relativa puesta en marcha del quemador, sería aconsejable efectuar los controles siguientes:

- La línea de alimentación debe ser adecuada a la carga absorbida por la instalación
- Los fusibles deben ser adecuados a la carga absorbida por la instalación
- Los termostatos de caldera tienen que ser correctamente conectados
- Voltaje y frecuencia deben estar en los límites especificados
- El tipo de combustible debe ser lo especificado por el fabricante del quemador
- La sección de la tubería de alimentación debe ser adecuada al caudal de fuel necesitado
- Los filtros, grifos y empalmes deben ser instalados correctamente
- La longitud del tubo de llama debe ser la especificada por el fabricante de la caldera
- El caudal de los inyectores debe ser proporcionado a la potencia de la caldera

**ANTES DE EFECTUAR EL RELLENO DEL CIRCUITO DEL COMBUSTIBLE
COMPROBAR LOS LO QUE SIGUE**

- Comprobar el sentido de rotación del motor.
- Que hay combustible en el tanque.
- Los grifos deben ser abiertos.
- La tubería de retorno del combustible debe ser libre de oclusiones.

Una vez que se han comprobados todos esos puntos, proceder de la manera siguiente:

- Conectar un manómetro para el control de la presión del combustible.
- Actuar manualmente el telerruptor motor bomba por medio de un destornillador, hasta que el circuito será lleno (fig B).

Nota: el circuito será lleno cuando el manómetro indicará una presión constante.

Una vez que se ha rellenado el circuito apagar el quemador, quiere decir.

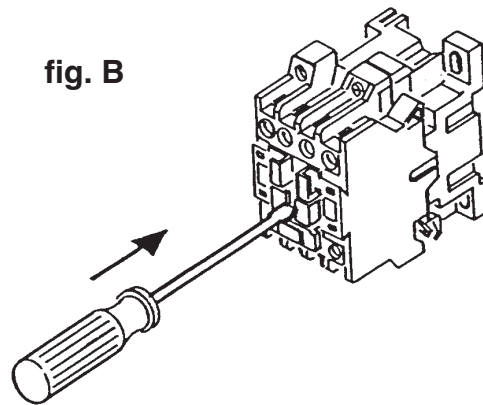

FUNCIONAMIENTO DEL QUEMADOR

Con el quemador en la posición start y los termostatos caldera habilitados, las resistencias (G) del precalentador, las resistencias auxiliares en la bomba y el grupo cabeza están bajo tensión. Cuando el termostato del precalentador alcanza el valor fijado (habitualmente es necesario un mínimo de 90°C para garantizar un buen nivel de circulación) la bomba de arranque está habilitada (si se utiliza el dispositivo de termostato GEFRAF 200 regular el set point en la salida 1).

Si el sistema de precalentamiento del depósito también está equipado para un cambiador de líquidos (agua caliente, vapor y aceite diatérmico) el termostato puede habilitar un contacto en el tablero de bornes para cualquier asenso eléctrico de la electroválvula para líquidos. Ésta no es una solución estándar, ya que el fluido calentado normalmente está siempre en circulación. La bomba empieza a enviar el aceite (la cabeza ya ha sido calentada por su resistencia (O) y, por lo tanto, no hay ningún residuo de aceite espeso frío) que fluye del depósito a la cabeza y luego a la línea de retorno del anillo de alimentación del aceite. Cuando el termostato de la cabeza alcanza el valor fijado (habitualmente unos 70-30°C) el ciclo empieza de manera apropiada y el aparato da el asenso al arranque del quemador. El servomotor se sitúa automáticamente en el mínimo (véase el capítulo de la regulación) actuando sobre la compuerta del aire y el retorno del regulador de presión para el aceite combustible.

El electroimán (A) abre la boquilla (Q) en la siguiente condición:

- las chispas de los electrodos de encendido son producidas por el transformador que también se regula automáticamente mediante el dispositivo de control del quemador.

Si la célula de detección no detecta la llama, el quemador se bloquea.

Una vez que se haya encendido y después del periodo de estabilización de la llama, el sistema empieza a funcionar en modulación.

- Antes del arranque asegurarse de que la bomba y los tubos de impulsión estén completamente llenos de aceite combustible caliente; la ausencia de aceite combustible puede causar el agarrotamiento de la bomba.

- Si hay un bloqueo, una luz específica de aviso en el programador y en el panel frontal de control del quemador se enciende y esta señal se envía habitualmente al aparato principal que el quemador utiliza, activando una alarma acústica y una luz de aviso.

- Algunos bloqueos son normales durante el primer arranque (hasta 4 aproximadamente); para desbloquear el sistema, pulsar la tecla del aparato (situada en la parte delantera del panel de control del quemador) para repetir el ciclo de arranque. Si el problema persiste dirigirse a un técnico especializado.

N.B. La posición del aparato en el momento del bloqueo indica sus posibles causas.

SOLO PARA EQUIPOS DE CONTROL LLAMA LANDIS LMO 44

En caso de bloqueo del quemador, es disponible la indicación del origen del bloqueo. Actuar de la manera siguiente: con el quemador en seguridad (LED rojo encendido) presionar por más de tres segundos el botón de rearme manual y aflojarlo. El LED rojo empezará a encenderse de luz intermitente, según la lista siguiente de códigos de error:

Códigos de error	Posible causa
2 parpadeos	Ausencia de llama al final del tiempo de seguridad en el encendido "TSA" -Electroválvula defectuosa -revelación de llama defectuosa -regulación del quemador incorrecta -electrodos defectuosos
3 parpadeos	No utilizado
4 parpadeos	Luz extraña durante la fase de prearranque
5 parpadeos	No utilizado
6 parpadeos	No utilizado
7 parpadeos	Falta de llama durante el funcionamiento (superado el límite de nº de repeticiones del ciclo) -Electroválvula defectuosa -Revelación de llama defectuosa -Regulación del quemador incorrecta
8 parpadeos	Control del tiempo de calentamiento del combustible
9 parpadeos	No utilizado
10 parpadeos	Contacto en la salida defectuosa o estropeado dispositivo interno

REGULACIÓN DE LA PRESIÓN DEL RETORNO DE FUEL PESADO

ES

El diagrama ilustra el sistema de regulación del retorno de fuel pesado para estos tipos de quemadores, los cuales han incorporado un un inyector con retorno variable progresivo. El caudal de fuel pesado puede variarse a través del inyector de retorno, cambiando la presión en el retorno. El caudal máxima de fuel pesado se obtiene, cuando la presión de la bomba es de unos 30 bar y el retorno está completamente cerrado. El caudal mínimo de fuel pesado se obtiene cuando la línea de retorno está completamente abierta. La presión en impulsión se lee, montando un manómetro en la bomba. La presión del retorno se lee en el manómetro montado a continuación del quemador en el regulador de presión.

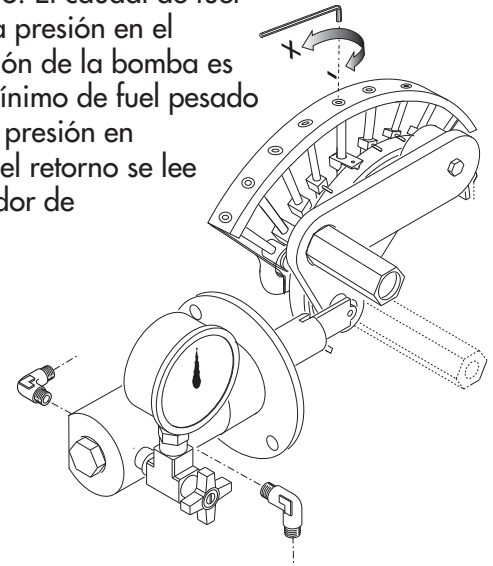

Presión bomba 25-30 bar.

Max caudal, presión retorno:

FLUIDICS inyector : 16 ÷ 19 bar.

BERGONZO inyector : 20 ÷ 24 bar.

Min caudal, presión retorno :

FLUIDICS inyector : 6 ÷ 9 bar

BERGONZO inyector : 4 ÷ 8 bar

FASE DE PREBARRIDO

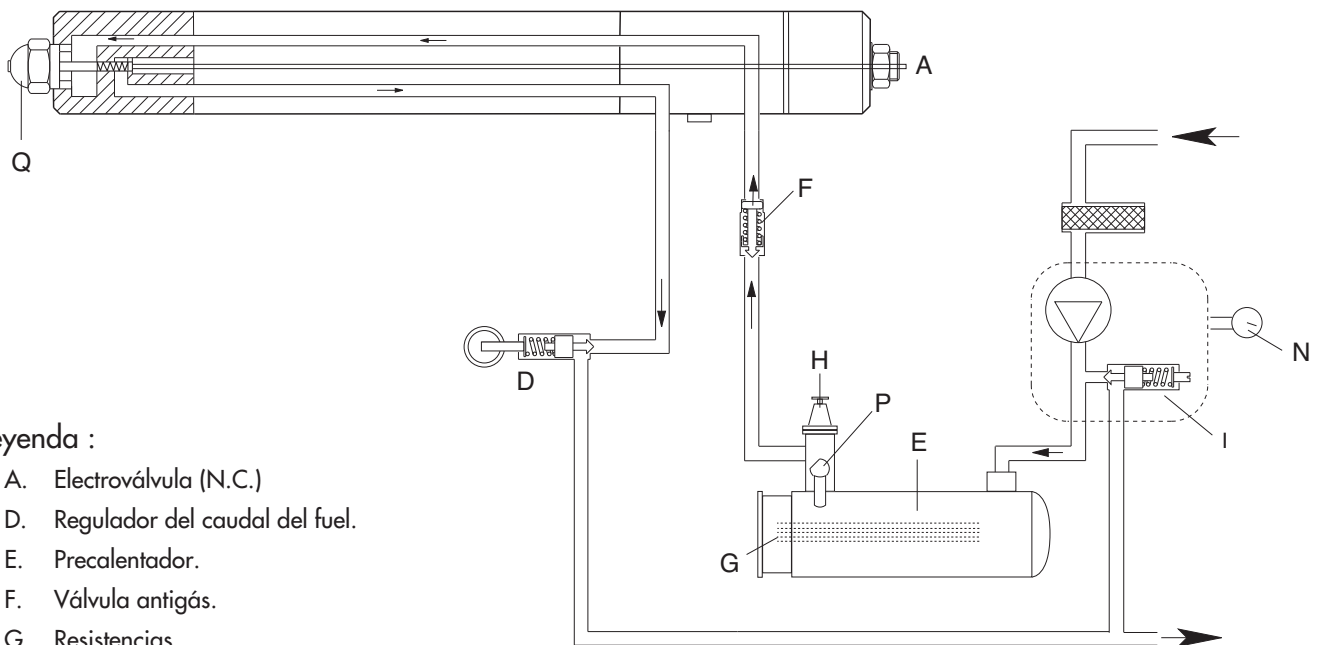

Leyenda :

- A. Electroválvula (N.C.)
- D. Regulador del caudal del fuel.
- E. Precalentador.
- F. Válvula antigás.
- G. Resistencias.
- H. Filtro.
- I. Bomba combustible.
- N. Manómetro.
- P. Puntas de prueba de la temperatura.
- Q. Inyector.
- N.C. = Norm. cerrada

REGULACIÓN SERVOMOTOR DEL CIERRE DEL AIRE LANDIS & GYR SQM 50.481A2



Sacar la tapa para acceder a las excéntricas de regulación.
El posicionamiento de las excéntricas deberá ser efectuado por medio de su propia llave de suministro. Descripción:

ES

- I - Leva de regulación abertura del cierre del aire en la potencia máx.
- II - Leva de regulación abertura del cierre del aire en ignición.
- III - Leva de regulación abertura del cierre del aire en la potencia min.
- IV - No utilizar.
- V - No utilizar.

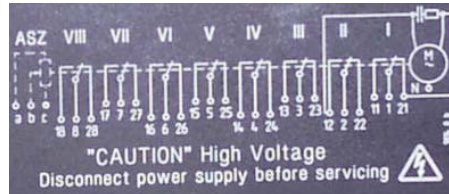

REGULACIÓN DE LOS TERMOSTATOS FUEL PESADO

El termostato de trabajo de las resistencias tiene que ser regulado a 120 °C y el termostato de seguridad a 160 °C. Estas regulaciones puedes ser ligeramente modificadas según el tipo de combustible y para instalaciones especiales.

- A - Termostato de seguridad (160° C).
- B - Termostato de trabajo (120° C).
- C - Termostato de nivelación (130° C).
- D - Termostato de minima fuel pesado (90° C).

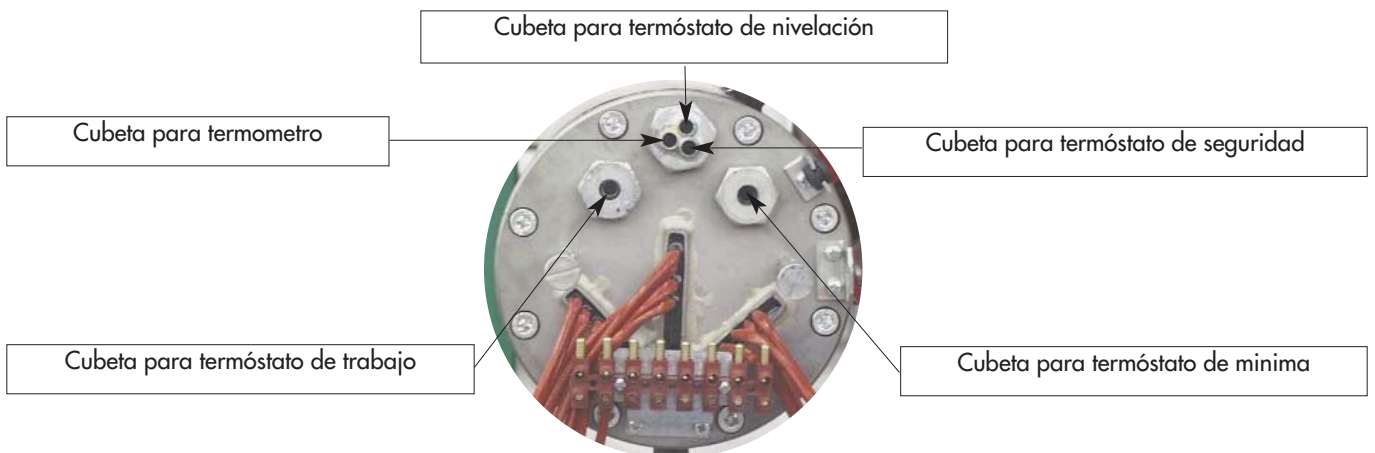
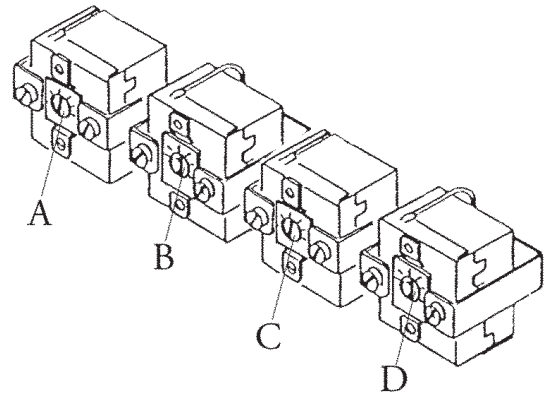

POSICIÓN DE LOS ELECTRODOS DE ENCENDIDO

Para un correcto encendido del quemador se necesita respetar las cuotas de la ilustración.

ES

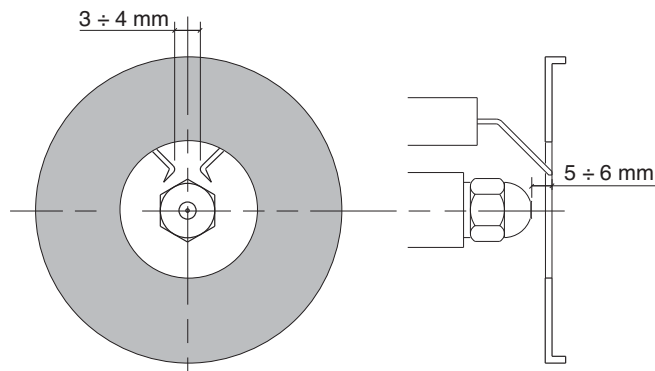

LIMPIEZA Y MANTENIMIENTO DE LOS FILTROS AL INTERIOR DEL TANQUE CALENTADOR

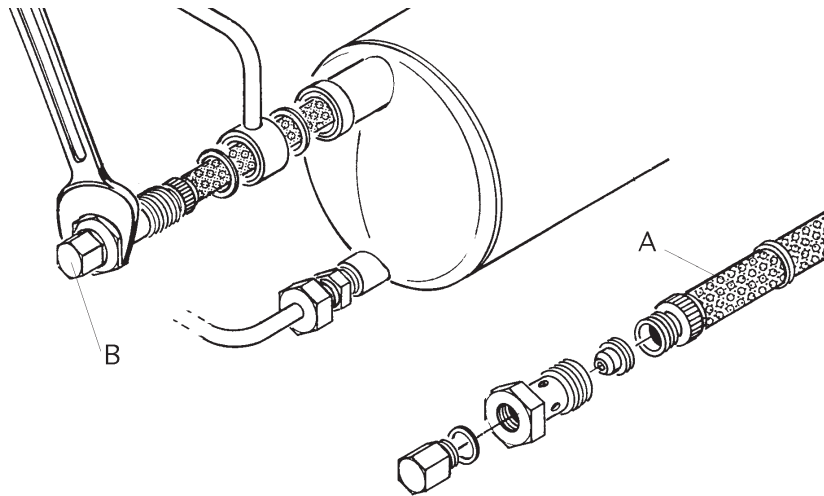

EXTRACCIÓN DEL FILTRO

1. Apagar el quemador
2. Aflojar el tornillo B y descargar una parte del aceite contenido en el tanque calentador para que el nivel del líquido descienda más bajo de lo del filtro.
3. Destornillar y sacar de su sede el mango del filtro A
4. Después de haber limpiado el filtro, remontar sus piezas como indicado por la ilustración y reintroducirlo en su propia sede.

Es una buena norma reemplazar todas las juntas del filtro cada vez que se desmontan los mismos.

Se recuerda que cada vez que el quemador es en marcha, en el calentador hay una presión cerca de 23 bar y que es muy peligroso efectuar dichas operaciones cuando el quemador está en función.

ANOMALÍAS DE FUNCIONAMIENTO

1 - El quemador no arranca:

- Interruptor de alimentación sobre OFF
- Fusibles quemados
- Termostatos de caldera abiertos
- Resistencias en avería
- Termostatos del calentador abiertos

2 - Las resistencias calientan pero el quemador no arranca:

- Termostatos averiados
- Interruptor en OFF
- Termostatos del calentador abiertos
- Equipo de control llama averiado

3 - El quemador efectúa el prebarrido pero se bloquea:

- Interruptor en OFF
- Equipo de control llama averiado
- Fotorresistencia averiada
- Cebado prematuro de llama siguiendo a una pérdida de fuel por la electroválvula

4 - El quemador no se enciende durante el ciclo y después se bloquea:

- Equipo de control llama averiado

5 - El quemador no se enciende:

- Electrodo sucios
- Electrodo estropeados
- Electrodo mal posicionados
- Transformador de encendido averiado
- Válvula de Baja Llama averiada
- Inyector obstruido
- Exceso de aire de combustión en relación al caudal de los inyectores
- Equipo de control llama averiado

6 - El quemador se enciende pero se bloquea

- Temperatura del fuel demasiado débil (llama irregular)
- Deterioro excesivo de los inyectores
- La fotorresistencia no percibe la llama
- Presión del fuel demasiado débil durante el prebarrido
- Exceso de aire de combustión en relación a los inyectores
- Equipo de control llama averiado
- Presión del fuel demasiado débil
- Filtros obstruidos

7 - El quemador no pasa en Alta Llama:

- Interruptor manual sobre I (Baja llama)
- Bobina de Alta llama averiada
- Presión del fuel demasiado débil
- Filtros obstruidos
- Inyector de Alta llama demasiado deteriorado o averiado
- Equipo de control llama averiado

8 - Presión del fuel demasiado débil o irregular:

- Filtros bomba y/o calentador obstruidos
- La electroválvula norm. abierta no se cierra
- Alimentación del fuel irregular
- Bomba averiada

индекс

RU

1 - ТЕХНИЧЕСКИЕ ХАРАКТЕРИСТИКИ

- ТЕХНИЧЕСКИЕ ХАРАКТЕРИСТИКИp.47
- РАБОЧИЙ ДИАПАЗОНp.47
- ГАБАРИТНЫЕ РАЗМЕРЫp.48

2 - МОНТАЖ

- МОНТАЖ ГОРЕЛКИp.48
- СИСТЕМА ПОДАЧИ МАЗУТАp.48
- ГРАФИК ЗАВИСИМОСТИ ДАВЛЕНИЯ НАСОСА И ТЕМПЕРАТУРЫ МАЗУТА .p.49
- Схема подачи мазута с вязкостью не болееp.50

3 - Стартер и регулировки

- ПРОВЕРКА ПРАВИЛЬНОСТИ МОНТАЖАp.51
- ПУСК ГОРЕЛКИp.52,53
- СХЕМА ЦИРКУЛЯЦИИ ТОПЛИВА НА ЭТАПЕ ПРОДУВКИp.53
- РЕГУЛИРОВКИp.54

4 - ПОЛЬЗА И ОБСЛУЖИВАНИЕ

- ОБСЛУЖИВАНИЕ ФИЛЬТРОВ БАЧКА-ПОДОГРЕВАТЕЛЯp.55
- НЕИСПРАВНОСТИ И СПОСОБЫ ИХ УСТРАНЕНИЯp.56

ТЕХНИЧЕСКИЕ ХАРАКТЕРИСТИКИ

RU

МОДЕЛЬ		OILFLAM 50.1	OILFLAM 80.1	OILFLAM 120.1	OILFLAM 170.1	OILFLAM 200.1
Макс. теплопроизводительность	ккал/час	500.000	800.000	1.200.000	1.462.000	1.800.000
	кВт	581	930	1395	1700	2093
Мин. теплопроизводительность.	ккал/час	250.000	400.000	588.000	588.000	588.000
	кВт	290	464	682	682	682
Максимальный расход мазута	кг/ч	51	82	122	148	184
Минимальный расход мазута	кг/ч	25,5	41	60	60	60
Максимальная вязкость		15°E а 50°С				
	version D	50°E а 50°С				
Напряжение электропитания, 50 Гц	В	230/400	230/400	230/400	230/400	230/400
Мощность двигателя	кВт	1,5	1,5	2,2	3	4
Двигатель	об./мин	2.800	2.800	2.800	2.800	2.800
Трансформатор розжига	кВ/мА	13/35	13/35	13/35	13/35	13/35
Рабочие нагревательные элементы	Вт	3 x 550	3 x 800	3 x 1350	3 x 1650	3 x 2000
Выравнивающие нагревательные элементы	Вт	3 x 450	3 x 750	3 x 1000	3 x 1350	3 x 1500
Контрольная аппаратура	LANDIS	LMO 44	LMO 44	LMO 44	LMO 44	LMO 44
Вид топлива, теплотворность: мазут		ккал/час 9.800				

РАБОЧИЙ ДИАПАЗОН

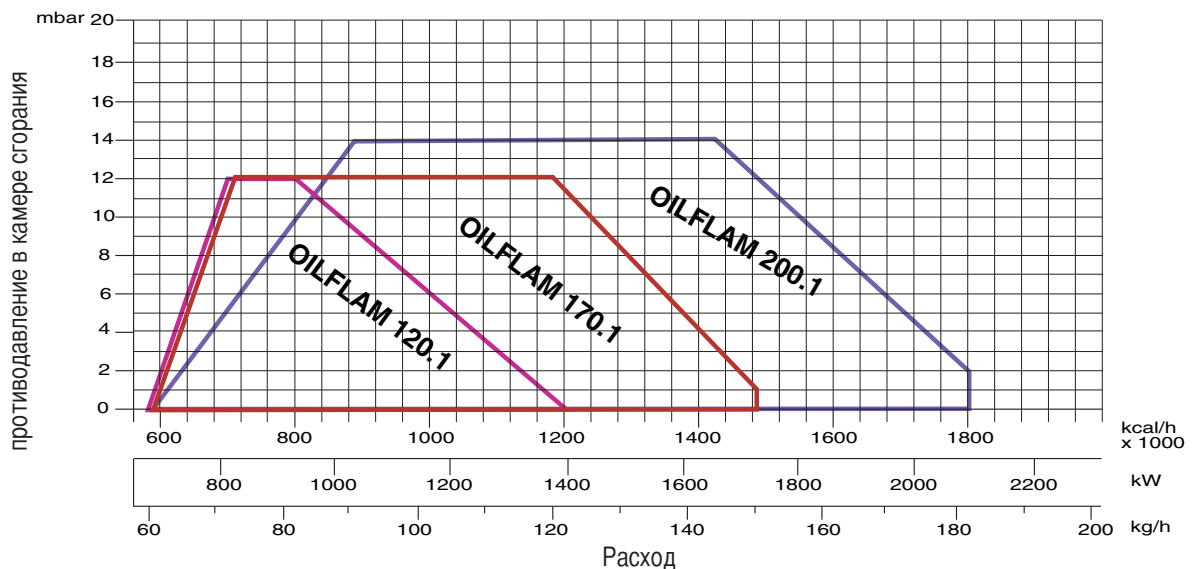
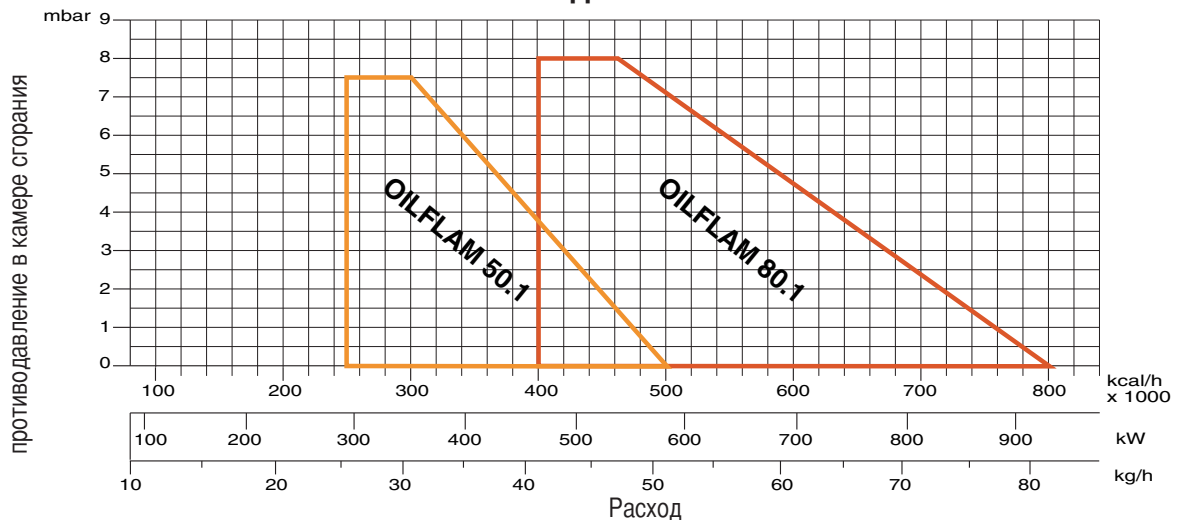

ГАБАРИТНЫЕ РАЗМЕРЫ

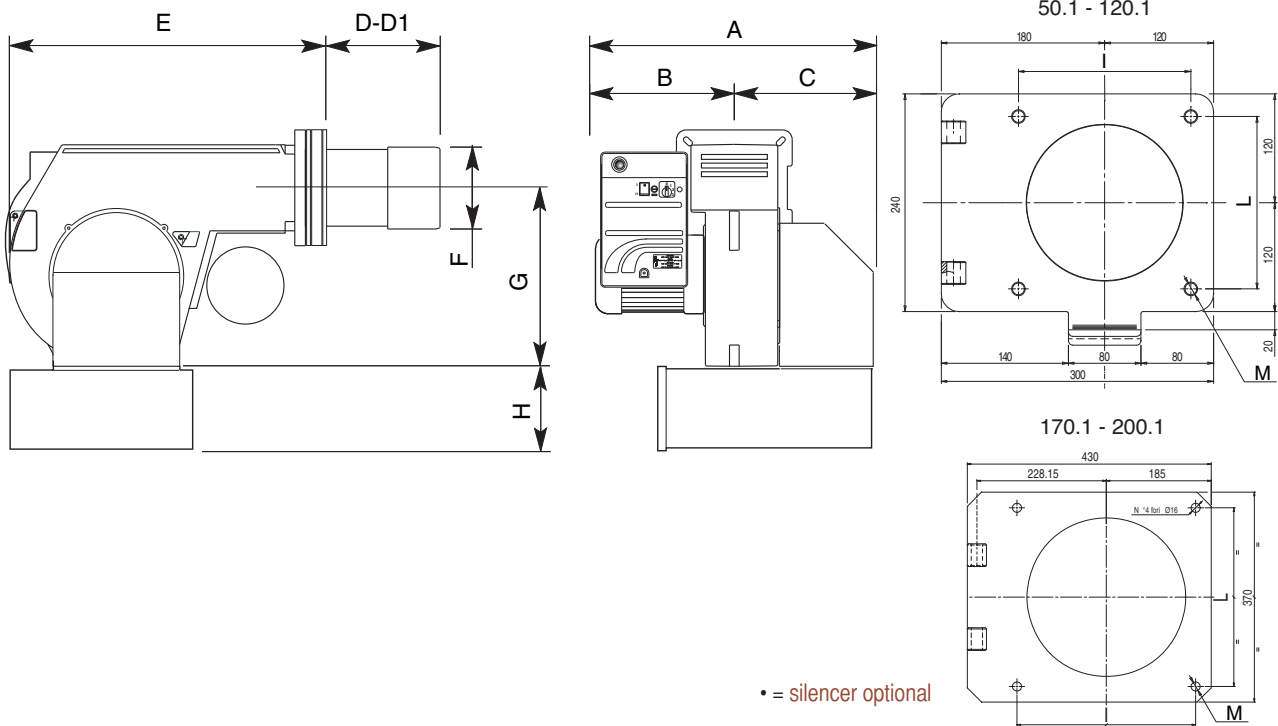

МОДЕЛЬ	A	B	C	D	D1	E	F	G	H	I	L	M
OILFLAM 50.1 PR	815	370	445	170	310	600	190	376	215●	190	190	M10
OILFLAM 80.1 PR	815	370	445	170	310	600	190	376	215●	190	190	M10
OILFLAM 120.1 PR	815	370	445	170	310	600	190	376	215●	190	190	M10
OILFLAM 170.1 PR	850	400	450	295	455	710	250	398	283●	315	315	M14
OILFLAM 200.1 PR	850	400	450	295	455	710	270	398	283●	315	315	M14

D = короткая огневая головка D1 = длинная огневая головка

МОНТАЖ ГОРЕЛКИ

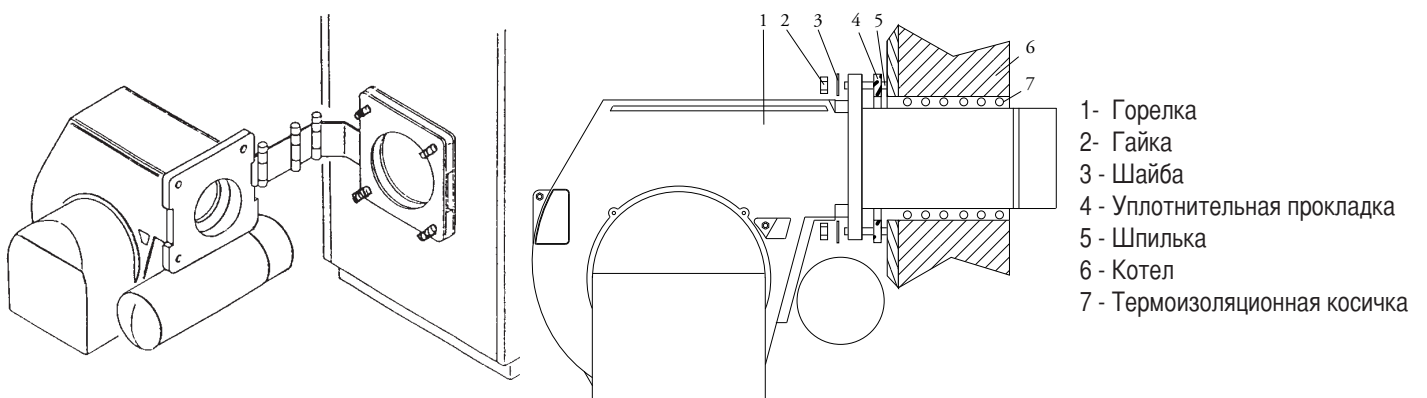

СИСТЕМА ПОДАЧИ МАЗУТА



ГРАФИК ЗАВИСИМОСТИ ДАВЛЕНИЯ НАСОСА И ТЕМПЕРАТУРЫ МАЗУТА

Переход в газообразную форму летучих фракций, содержащихся в подогретом мазуте, является основной причиной преждевременного износа топливного насоса. Для предупреждения этого явления давление на всасывании насоса должно быть отрегулировано, как показано на нижеприведенном графике.

RU

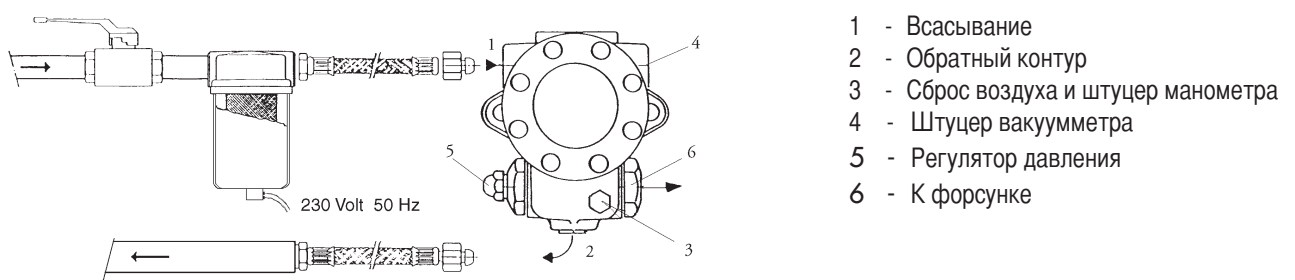
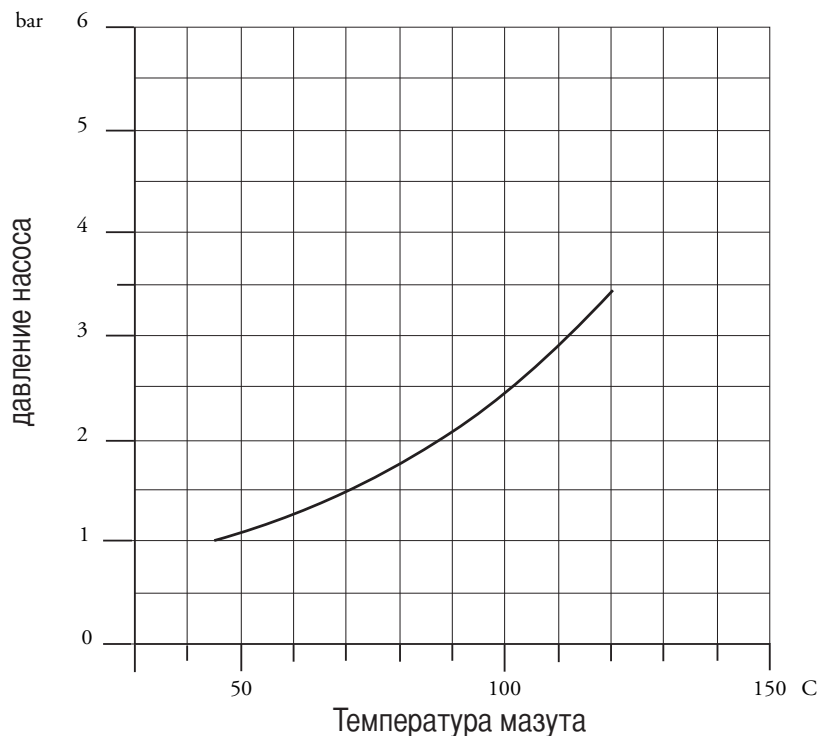

ВНИМАНИЕ: Для обеспечения эффективной работы насоса следует убедиться, что соблюдаются следующие условия:

Насос:

SUNTEC E...NC 1069

Температура топлива в насосе:

не более 120 °C

Максимальное допустимое давление:

не более 3,5 бар на всасывании.

Схема подачи мазута с вязкостью не более 50°Е при 50°С

RU

Сечение А-А

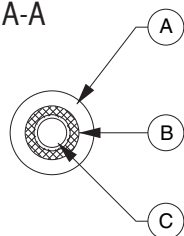

Экспликация
 А - Изоляция
 В - Греющий кабель
 С - Топливопровод

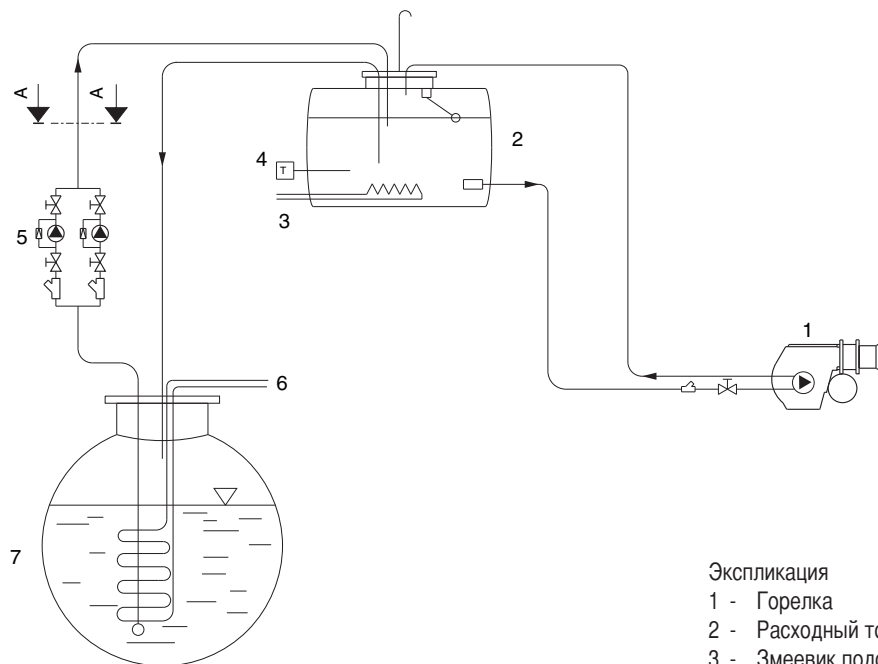

Экспликация
 1 - Горелка
 2 - Расходный топливный бак
 3 - Змеевик подогрева
 4 - Термостат
 5 - Перекачивающие насосы
 6 - Змеевик подогрева
 7 - Топливный бак
 8 - Байпас
 9 - Регулятор давления

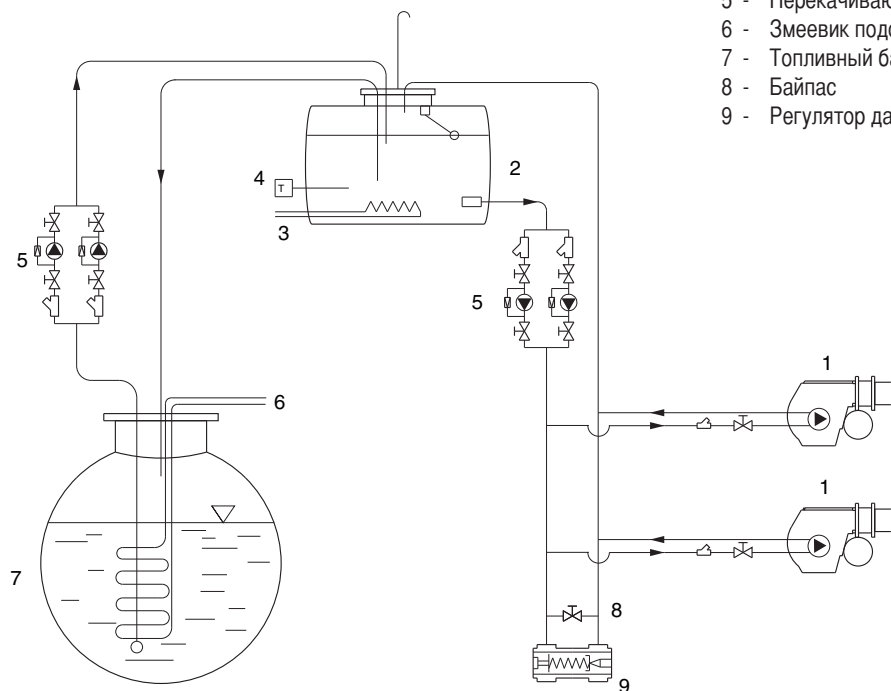

ВНИМАНИЕ: Все топливопроводы должны быть оснащены греющим кабелем и изолированы (см. сеч. А-А).

ПРОВЕРКА ПРАВИЛЬНОСТИ МОНТАЖА

Прежде чем, приступить к заполнению топливопровода и к последующему пуску оборудования рекомендуется убедиться в том, что:

- Система электроснабжения соответствует потребляемой мощности оборудования.
- Предохранители соответствуют нагрузке.
- Термостаты котла подключены правильно.
- Напряжение и частота тока не превышают указанных для данной горелки значений.
- Тип топлива соответствует рекомендованному производителем горелки.
- Сечение топливопроводов обеспечивает требуемый расход топлива.
- Фильтры, вентили и фитинги смонтированы правильно.
- Длина стакана горелки соответствует характеристикам котла.
- Производительность форсунок соответствует мощности котла.

RU

ПЕРЕД ЗАПОЛНЕНИЕМ ТОПЛИВОПРОВОДА МАЗУТОМ ВЫПОЛНИТЬ СЛЕДУЮЩЕЕ

- Проверить направление вращения двигателя (при трехфазном электропитании)
- Проверить наличие топлива в баке
- Убедиться, что вентили топливопровода находятся в открытом положении
- Убедиться, что обратный топливопровод свободен от каких-либо препятствий

После проверки выполнить следующее:

- Присоединить манометр для контроля давления топлива
- Нажать отверткой на дистанционный выключатель двигателя насоса и не отпускать до тех пор, пока топливный контур не заполнится (рис. 5).

Примечание: контур считается заполненным, когда давление на манометре стабилизируется в диапазоне.

После того, как топливопровод заполнился, и установить все элементы в исходное положение.

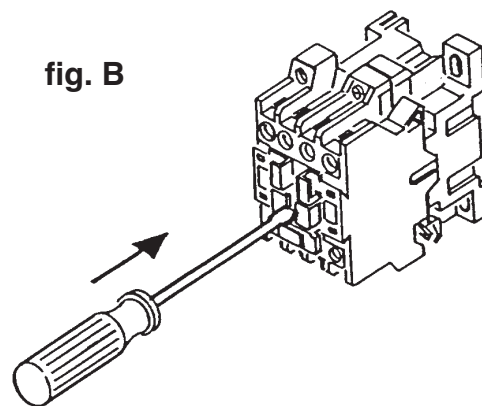

МОДУЛЯЦИЯ

Когда выключатель горелки находится в положении "пуск", а контакты термостатов замкнуты, напряжение подается на электроннагревательные элементы (G) в бачке горелки и насосов и в линию топливоснабжения и огневую головку (O). Когда термостат в бачке горелки определяет заданную температуру (обычно, для обеспечения хорошей циркуляции не менее 90С), включается насос (при использовании терморегулятора GEFRAN 200 уставка – 1). Если в системе предварительного подогрева предусмотрен жидкостный теплообменник (горячая вода, пар, диатермическое масло), термостат может передавать сигнал, включающий или выключающий электроклапан, который регулирует ток жидкости.

Это не является стандартным решением, поскольку ток теплоносителя, как правило, никогда не перекрывается. Насос начинает подавать топливо (поскольку огневая головка уже разогрета соответствующим Тэном (O), в ней нет застывшего холодного мазута). Топливо поступает из бака в головку и в обратный контур.

Когда термостат головки определяет заданную температуру (обычно 70-30°C) начинается рабочий цикл и регулятор дает разрешение на пуск. Сервопривод автоматически устанавливается на минимум (см. описание регулировки) и регулирует расход воздуха и топлива посредством регулятора давления в обратном контуре. Электромагнит (A) открывает форсунку (Q) при следующих условиях:

- электроды розжига, на которые с трансформатора поступает ток, создают искру. Трансформатор находится под контролем блока управления горелки.

Если фотоэлемент не обнаруживает пламя, горелка выключается (цикл контролируется регулятором). Когда же розжиг прошел успешно и после стабилизации факела система начинает работать в режиме модуляции. Перед пуском необходимо убедиться, что насос и топливопровод заполнены горячим мазутом - работа насоса без топлива может привести к его разрушению. Если происходит блокировка, на регуляторе и на блоке управления горелки загораются предупреждающие индикаторы. Этот сигнал обычно также подается на аппаратуру управления оборудования, с которым используется горелка, и включает зуммер и световую аварийную индикацию. Несколько блокировок (до 4) при первом пуске являются нормальным явлением. Для сброса блокировки и повтора цикла нажать кнопку на регуляторе (такая кнопка имеется также на пульте управления горелки). Если блокировки продолжаются, следует обратиться к сервисному специалисту.

ВНИМАНИЕ: В целях выявления причины блокировки положение регулятора на момент блокировки вносится в память.

ТОЛЬКО ДЛЯ ЭЛЕКТРОННОЙ АППАРАТУРЫ LANDIS LMO 44

На случай аварийной блокировки горелки предусмотрена система диагностики причин, повлекших за собой блокировку.

Диагностика осуществляется следующим образом:

При действующей аварийной блокировке (горит индикатор красного цвета) нажмите и не отпускайте в течение 3 секунд кнопку перезапуска. Индикатор красного цвета начинает мигать. Причины блокировки расшифровываются, как показано в таблице ниже:

Код ошибки	Возможная причина
2 импульса	По истечении времени аварийной остановки розжиг не произошел. - вышли из строя электроклапаны - вышел из строя электрод обнаружения пламени - неправильно отрегулирована горелка - вышли из строя электроды.
3 импульса	Значение не присвоено.
4 импульса	Посторонние источники света во время предварительной продувки.
5 импульсов	Значение не присвоено.
6 импульсов	Значение не присвоено.
7 импульсов	Исчерпано предельное количество гашений факела во время работы (превышен предел повторов цикла) - вышли из строя электроклапаны - вышел из строя электрод обнаружения пламени - неправильно отрегулирована горелка.
8 импульсов	Контроль времени подогрева топлива.
9 импульсов	Значение не присвоено.
10 импульсов	Неисправны контакты на выходе или внутренняя неисправность аппаратуры.

РЕГУЛИРОВКА ДАВЛЕНИЯ ТОПЛИВА В ОБРАТНОМ КОНТУРЕ

На рисунке показана система регулирования топлива в обратном контуре в горелках, где используется форсунка с поступательным регулированием расхода топлива в обратном контуре. Расход топлива может регулироваться путем изменения давления в обратном контуре форсунки. Максимальный расход топлива достигается, когда давление насоса равняется примерно 30 бар, а обратный контур полностью перекрыт. Минимальный расход топлива достигается, когда обратный контур полностью открыт. Давление на выходе насоса определяется с помощью манометра, который устанавливается на насосе. Давление в обратном контуре определяется по манометру, установленному на регуляторе давления горелки (включен в комплект поставки).



RU

Напор топливного насоса 25-30 бар.

Обратное давление топлива при максимальной мощности горелки:

форсунка FLUIDICS : 16 -19 бар.

форсунка BERGONZO : 20 -24 бар.

Обратное давление топлива при максимальной мощности горелки:

форсунка FLUIDICS: 6-9 бар

форсунка BERGONZO: 4 -8 бар

СХЕМА ЦИРКУЛЯЦИИ ТОПЛИВА НА ЭТАПЕ ПРОДУВКИ

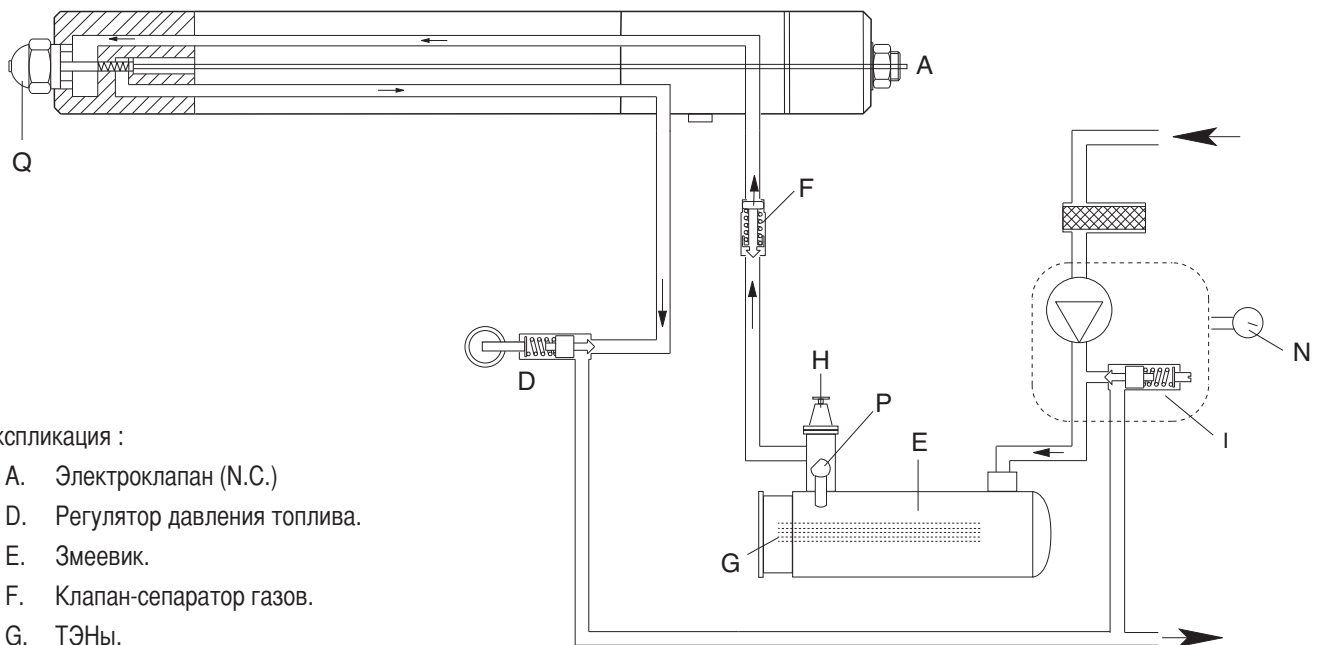

Экспликация :

- A. Электродвигатель (N.C.)
- D. Регулятор давления топлива.
- E. Змеевик.
- F. Клапан-сепаратор газов.
- G. ТЭНы.
- H. Фильтр.
- I. Топливный насос.
- N. Манометр.
- P. Датчик температуры топлива
- Q. Форсунка.
- N.C. = норма закрыто

РЕГУЛИРОВАНИЕ СЕРВОПРИВОДА LANDIS & GYR SQM 50.481A2

RU



Для доступа к регулировочным кулачкам снять крышку. Регулирование кулачков производится входящим в комплект ключом. Описание:

- I - Кулачок для регулировки расхода воздуха на максимальной мощности.
- II - Кулачок для регулировки положения заслонки во время гашения (закрывание).
- III - Кулачок для регулировки расхода воздуха на минимальной мощности.
- IV - Не используется
- V - Не используется.

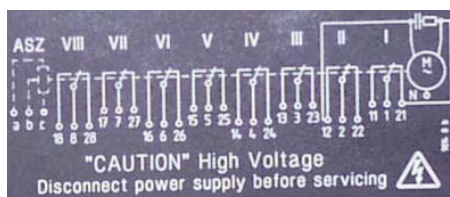

РЕГУЛИРОВАНИЕ ТОПЛИВНЫХ ТЕРМОСТАТОВ

Рабочий термостат нагревательных элементов устанавливается на 120 °С, а предохранительный - на 160 °С. Эти значения могут незначительно изменяться в зависимости от типа топлива и иных условий эксплуатации.

- A - Предохранительный термостат (160° С).
- B - Рабочий термостат (120° С).
- C - Выравнивающий термостат (130°С).
- D - Термостат минимальной температуры мазута. (90° С).

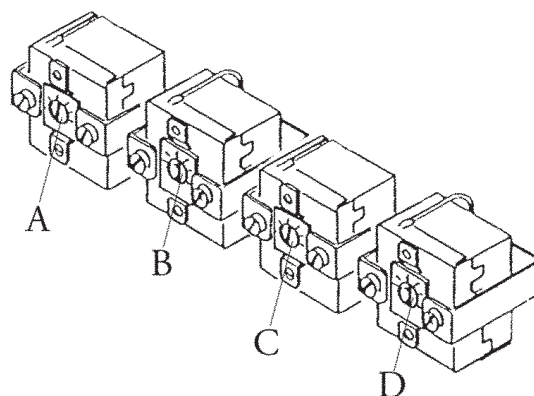

Посадочное гнездо выравнивающего термостата

Посадочное гнездо термометра

Посадочное гнездо предохранительного

Посадочное гнездо рабочего термостата

Посадочное гнездо термостата минимальной температуры

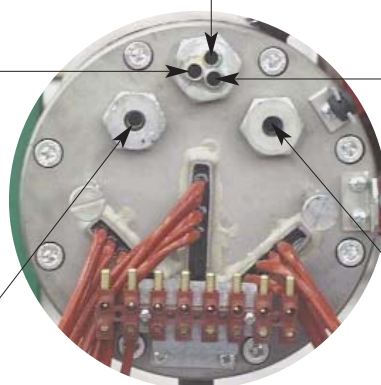

ПОЛОЖЕНИЕ ЭЛЕКТРОДОВ РОЗЖИГА

Для обеспечения правильного розжига горелки необходимо, чтобы были соблюдены показанные на рисунке ниже зазоры.

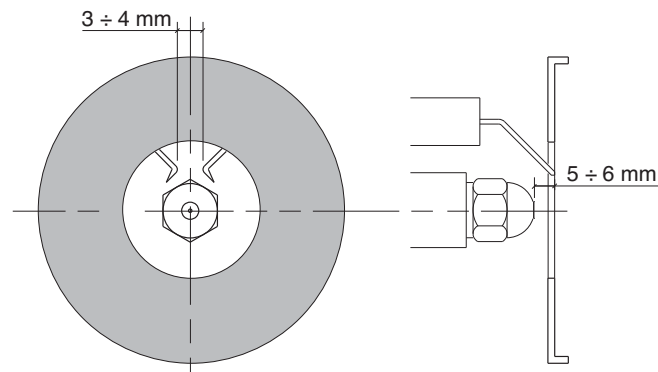

RU

ОБСЛУЖИВАНИЕ ФИЛЬТРОВ БАЧКА-ПОДОГРЕВАТЕЛЯ

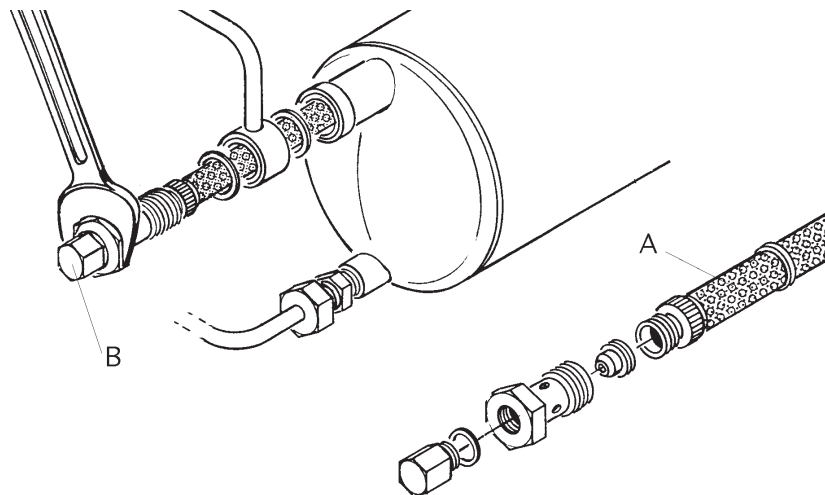

ДЕМОНТАЖ ФИЛЬТРА

- 1) Выключить горелку.
- 2) Ослабить винт В и слить из бачка мазут, так чтобы его уровень опустился ниже фильтра.
- 3) Отвинтить и извлечь из посадочного гнезда шток А.
- 4) После чистки фильтра собрать его как показано на рисунке и вставить в посадочное гнездо.

Всякий раз, когда демонтируются фильтр и клапан рекомендуется заменить весь комплект соответствующих прокладок.

Напоминаем, что во время работы горелки бачок-подогреватель находится под давлением приблизительно 23 бар, поэтому проводить вышеописанные работы при работающей горелке очень опасно.

НЕИСПРАВНОСТИ И СПОСОБЫ ИХ УСТРАНЕНИЯ

RU

- 1 - Не происходит запуск горелки:
 - Выключатель в положении Выкл.
 - Перегорели предохранители.
 - Термостат котла не замыкает электрическую цепь.
 - Повреждены нагревательные элементы.
 - Термостат бачка-подогревателя не замыкает электрическую цепь.
- 2 - Нагревательные элементы работают, но запуск горелки не происходит:
 - Вышли из строя термостаты.
 - Выключатель в положении Выкл.
 - Термостат бачка-подогревателя не замыкает электрическую цепь.
 - Вышла из строя контрольная аппаратура.
- 3 - После продувки происходит остановка горелки:
 - Выключатель в положении Выкл.
 - Вышла из строя контрольная аппаратура.
 - Поврежден фотодатчик.
 - Преждевременный розжиг, вызванный негерметичностью топливного клапана.
- 4 - В течение цикла розжиг горелки не происходит, затем горелка блокируется:
 - Вышла из строя контрольная аппаратура.
- 5 - Не происходит розжиг горелки:
 - Загрязнены электроды.
 - Повреждены электроды.
 - Электроды расположены неправильно.
 - Вышел из строя трансформатор.
 - Вышел из строя клапан первой ступени.
 - Засорены форсунки.
 - Избыток воздуха при данном расходе через форсунки.
 - Вышла из строя контрольная аппаратура.
- 6 - После нормального розжига происходит блокировка горелки:
 - Недостаточная температура топлива (факел неправильной формы).
 - Форсунки слишком изношены.
 - Фотодатчик "не видит" пламя.
 - Недостаточное давление топлива во время продувки.
 - Избыток воздуха при данном расходе через форсунки.
 - Вышла из строя контрольная аппаратура.
 - Недостаточное давление топлива.
 - Засорены форсунки.
- 7 - Горелка не переходит на 2-ую ступень мощности:
 - Ручной переключатель режимов находится в положении 1-й ступени.
 - Вышла из строя катушка клапана 2-й ступени.
 - Недостаточное давление топлива.
 - Засорены фильтры.
 - Форсунка 2-й ступени изношена или засорена.
 - Вышла из строя контрольная аппаратура.
- 8 - Давление мазута недостаточно либо нестабильно:
 - Фильтры насоса и/или бачка-подогревателя засорены.
 - Нормально открытый электроклапан не закрывается.
 - Ненормативное давление топлива.
 - Поврежден насос.

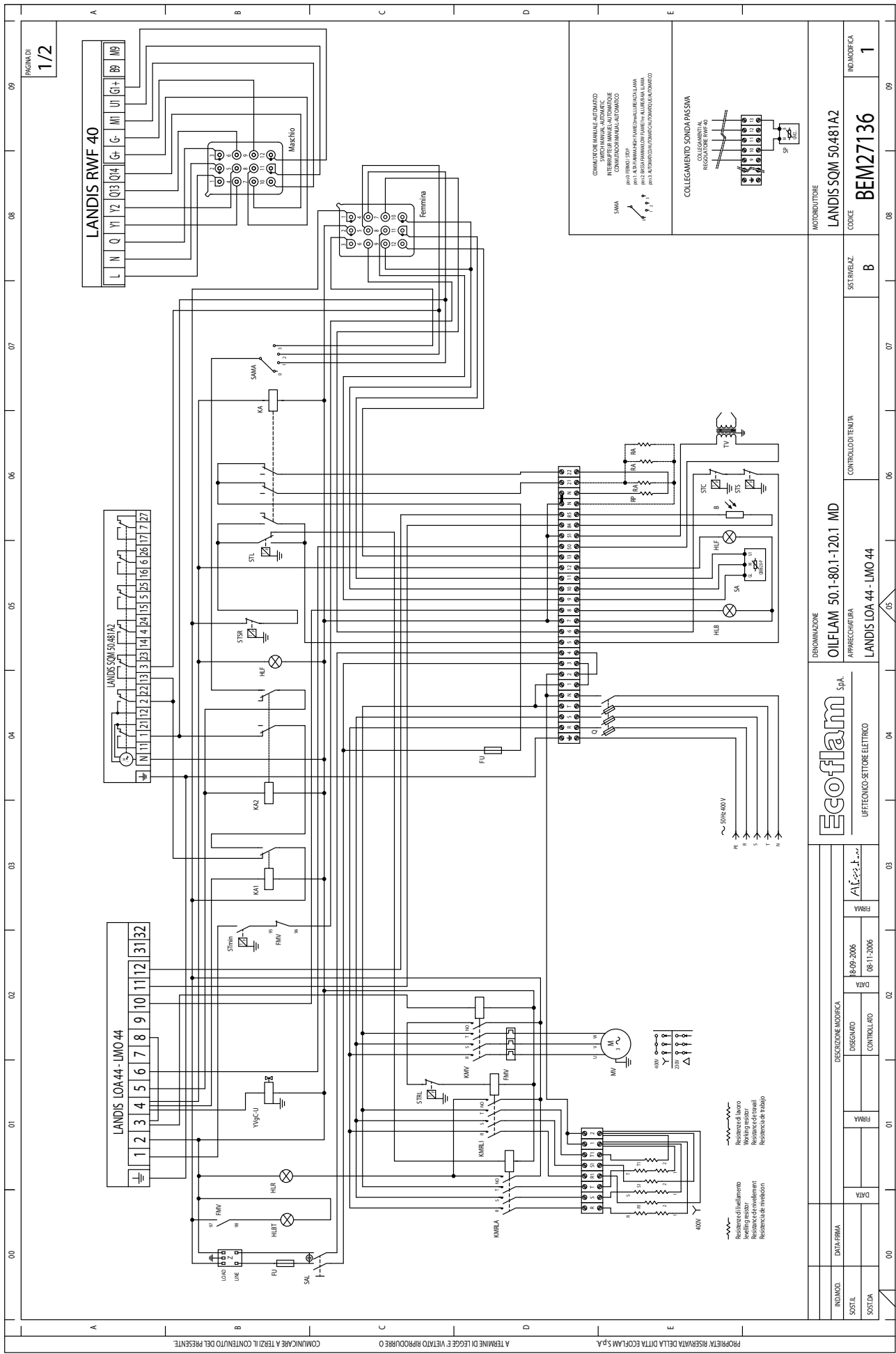

COMANDI TORNA MANE AUTOMATICO
INTERPRETER MANE AUTOMATIQUE
COMANDO TORNA MANE AUTOMATICO

PAI 1 SERVO MOTOR
PAI 2 SERVO MOTOR
PAI 3 SERVO MOTOR
PAI 4 SERVO MOTOR
PAI 5 SERVO MOTOR
PAI 6 SERVO MOTOR
PAI 7 SERVO MOTOR
PAI 8 SERVO MOTOR
PAI 9 SERVO MOTOR
PAI 10 SERVO MOTOR
PAI 11 SERVO MOTOR
PAI 12 SERVO MOTOR
PAI 13 SERVO MOTOR
PAI 14 SERVO MOTOR
PAI 15 SERVO MOTOR
PAI 16 SERVO MOTOR
PAI 17 SERVO MOTOR
PAI 18 SERVO MOTOR
PAI 19 SERVO MOTOR
PAI 20 SERVO MOTOR
PAI 21 SERVO MOTOR
PAI 22 SERVO MOTOR
PAI 23 SERVO MOTOR
PAI 24 SERVO MOTOR
PAI 25 SERVO MOTOR
PAI 26 SERVO MOTOR
PAI 27 SERVO MOTOR

COLLEGAMENTO SONDA P/S SVA
COLLEGAMENTO SVA
REGOLATORE SVA

MOTRIBUTTORE	LANDIS SQM 50.481A2
CODICE	BEM27136
IND. MODIFICA	1

DENOMINAZIONE	OILFLAM 50.1-80.1-120.1 MD
APPARECCHIATURA	LANDIS LOA 44-LMO 44
CONTROLLO TEMPI	
SIST. RELAZ.	B

IND. MOD.	DATA-FIRMA
SOSTIT.	DATA
SOST. DA	DATA

DESCRIZIONE MODIFICA	FRMA
DESEGNATO	DATA
CONTROLLATO	DATA

IND. MOD.	DATA-FIRMA
SOSTIT.	DATA
SOST. DA	DATA

PROPRIETA' RISERVATA DELLA DITTA ECOFLAM S.P.A.
A TERMINI DI LEGGE E VIETATO RIPRODURRE O COMUNICARE A TERZI IL CONTENUTO DEL PRESENTE

PAGINA DI
2/2

A	B	C	D	E																
<p>B FOTORESISTENZA PHOTO-RESISTOR FOTORESISTENCIA</p> <p>Q INTERRUPTORE GENERALE CON FUSIBILE MAIN SWITCH WITH FUSE INTERRUPTEUR GENERAL AVEC FUSIBLE INTERUPTOR GENERAL CON FUSIBLE</p> <p>Z FILTRO ANTIDISTURBO ANTI-JAMMING FILTER FILTRE ANTI PARASITES FILTRO DE PROTECCION ANTIDISTURBO</p> <p>FU FUSIBILE FUSE FUSIBLE FUSIBLE</p> <p>RA1 RELE RELAY RELAIS RELE</p> <p>RA2 RELE RELAY RELAIS RELE</p> <p>MV MOTORE VENTILATORE MOTOR FAN MOTOR VENTILATEUR MOTOR VENTILADOR</p> <p>RA RESISTENZA AUSILIARIA AUXILIARY RESISTOR RESISTENCIA AUXILIARE RESISTENCIA AUXILIARIA</p> <p>RP RESISTENZA POMPA PUMP RESISTOR RESISTANCE POMPE RESISTENCIA BOMBA</p> <p>TV TRASFORMATORE IGNITION TRANSFORMER TRANSFORMATEUR D'ALLUMAGE TRANSFORMADOR</p> <p>RMV RELE TERMICO MOTORE VENTILATORE MOTOR THERMAL RELAY (FAN MOTOR) RELAIS THERMIQUE MOTEUR VENTILATEUR RELE TERMICO MOTOR VENTILADOR</p> <p>HLB LAMPADA DI BLOCCO LOCK-OUT LAMP LAMPE DE SECURITE ESPIA DE BLOQUEO</p> <p>HLF LAMPADA DI FUNZIONAMENTO WORKING LAMP LAMPE DE FONCTIONNEMENT ESPIA DE FUNCIONAMIENTO</p> <p>HLR LAMPADA RESISTENZE RESISTOR LAMP THERMIN RESISTENCES INDICADOR RESISTENCIAS</p> <p>RMV CONFETTORE MOTORE VENTILATORE BEHOLD CONTACT SWITCH (FAN MOTOR) CONTACTEUR MOTEUR VENTILATEUR TELEINTERRUPTOR MOTOR VENTILADOR</p>	<p>SAL INTERRUPTORE DI LINEA WORKING SWITCH INTERRUPTEUR DE LIGNE INTERUPTOR DE LINEA</p> <p>STC TERMOSTATO CADENA BOILER THERMOSTAT THERMOSTAT CHAUDIERE THERMOSTATO CADENA</p> <p>STL TERMOSTATO DI LAVORO WORKING THERMOSTAT THERMOSTAT TRAVAIL THERMOSTATO DE TRABAJO</p> <p>ST5 TERMOSTATO DI SICUREZZA SAFETY THERMOSTAT THERMOSTAT DE SECURITE THERMOSTATO DE SEGURIDAD</p> <p>STRL TERMOSTATO RESISTENZE DI LIVELLAMENTO LEVELING RESISTOR THERMOSTAT THERMOSTAT DES RESISTANCES DE NIVELLEMENT THERMOSTATO DE LAS RESISTENCIAS DE NIVELACION</p> <p>STR TERMOSTATO DI SICUREZZA RESISTENZE RESTOR SAFETY THERMOSTAT THERMOSTAT DE SECURITE RESISTANCES THERMOSTATO DE SEGURIDAD RESISTENCIAS</p> <p>MRILA CONTATTORE RESISTENZE DI LAVORO WORKING CONTACTOR INTERRUPTEUR DES RESISTANCES DE TRAVAIL INTERUPTOR DE LAS RESISTENCIAS DE TRABAJO</p> <p>MRIL CONTATTORE RESISTENZE DI LIVELLAMENTO LEVELING RESISTOR SWITCH INTERRUPTEUR DES RESISTANCES DE NIVELLEMENT INTERUPTOR DE LAS RESISTENCIAS DE NIVELACION</p> <p>STmin TERMOSTATO DI MINIMA THERMOSTAT MIN THERMOSTAT DE MIN THERMOSTATO DE MINIMA</p> <p>YVgCU SOLENOIDE CHIUSURA VELO SOLENOID VALVE</p> <p>SA SONDA ATTIVA USIN GATIVE SONDE ACTIVE SONDA ACTIVA</p> <p>SP SONDA PASSIVA USIN PASSIVE SONDE PASSIVE SONDA PASIVA</p> <p>HLBT LAMPADA DI BLOCCO TERMICO THERMAL LOCK-OUT LAMP LAMPE DE THERMAL DE SECURITE ESPIA DE BLOQUEO RELE TERMICO</p>	<p>LANDIS SQM 50.381A2</p> <p>70° I: CANNA DI REGOLAZIONE ARIA DI MASSIMA (15°) II: CANNA DI REGOLAZIONE ARIA DI ACCENSIONE 80° III: CANNA DI REGOLAZIONE ARIA DI BASSA 0° IV: CANNA NON UTILIZZATA 0° V: CANNA NON UTILIZZATA</p>	<table border="1" style="width: 100%; border-collapse: collapse;"> <thead> <tr> <th colspan="2">RESISTENZE BAMBOTTO OILFLAM PREHEATER RESISTORS OILFLAM RESISTENCIAS PRECALENTADOR OILFLAM</th> </tr> <tr> <th>Modello Modelo</th> <th>Totale Total</th> </tr> </thead> <tbody> <tr> <td>30</td> <td>3000 W</td> </tr> <tr> <td>50</td> <td>15300 W</td> </tr> <tr> <td>100</td> <td>30600 W</td> </tr> <tr> <td>120</td> <td>36720 W</td> </tr> <tr> <td>150</td> <td>45000 W</td> </tr> <tr> <td>200</td> <td>61200 W</td> </tr> </tbody> </table> <p>230V</p>	RESISTENZE BAMBOTTO OILFLAM PREHEATER RESISTORS OILFLAM RESISTENCIAS PRECALENTADOR OILFLAM		Modello Modelo	Totale Total	30	3000 W	50	15300 W	100	30600 W	120	36720 W	150	45000 W	200	61200 W	<p>ATTENZIONE: LE RESISTENZE AUSILIARIE "RA" SONO DI SERIE SOLO PER BRUCIATORI OILFLAM 50-80-120 AB/D</p> <p>WARNING: THE AUXILIARY RESISTORS "RA" ARE CURRENTLY SUPPLIED WITH OILFLAM 50-80-120 AB/D BURNERS ONLY</p> <p>ATTENTION: LES RESISTANCES AUXILIAIRES "RA" SONT DE SERIE SEULEMENT SUR LES BRULAIRES OILFLAM 50-80-120 AB/D</p> <p>CUIDADO: LAS RESISTENCIAS AUXILIARIAS "RA" SON DE SERIE SOLO PARA LOS QUEBADORES OILFLAM 50-80-120 AB/D</p>
RESISTENZE BAMBOTTO OILFLAM PREHEATER RESISTORS OILFLAM RESISTENCIAS PRECALENTADOR OILFLAM																				
Modello Modelo	Totale Total																			
30	3000 W																			
50	15300 W																			
100	30600 W																			
120	36720 W																			
150	45000 W																			
200	61200 W																			

COMINCIARE A TENDI IL CONTUTTO DEL PRESENTE

A TERMINI DI LEGGE E' VIETATO RIPRODURRE O

PROPRIETA' RISERVATA DELLA DITTA ECOFLAM S.p.A.

DENOMINAZIONE
OILFLAM 50.1-80.1-120.1 MD

APPARECCHIATURA
LANDIS LOA 44

MOTORBUITORE
LANDIS SQM 50.481A2

CODICE
BEM27136

CONTROLLO DI TENUTA

SIST. RIELEAZ.
B

Ecoflam

UFF. TECNICO-SETTORE ELETTRICO

Firma

18-09-2006

DATA

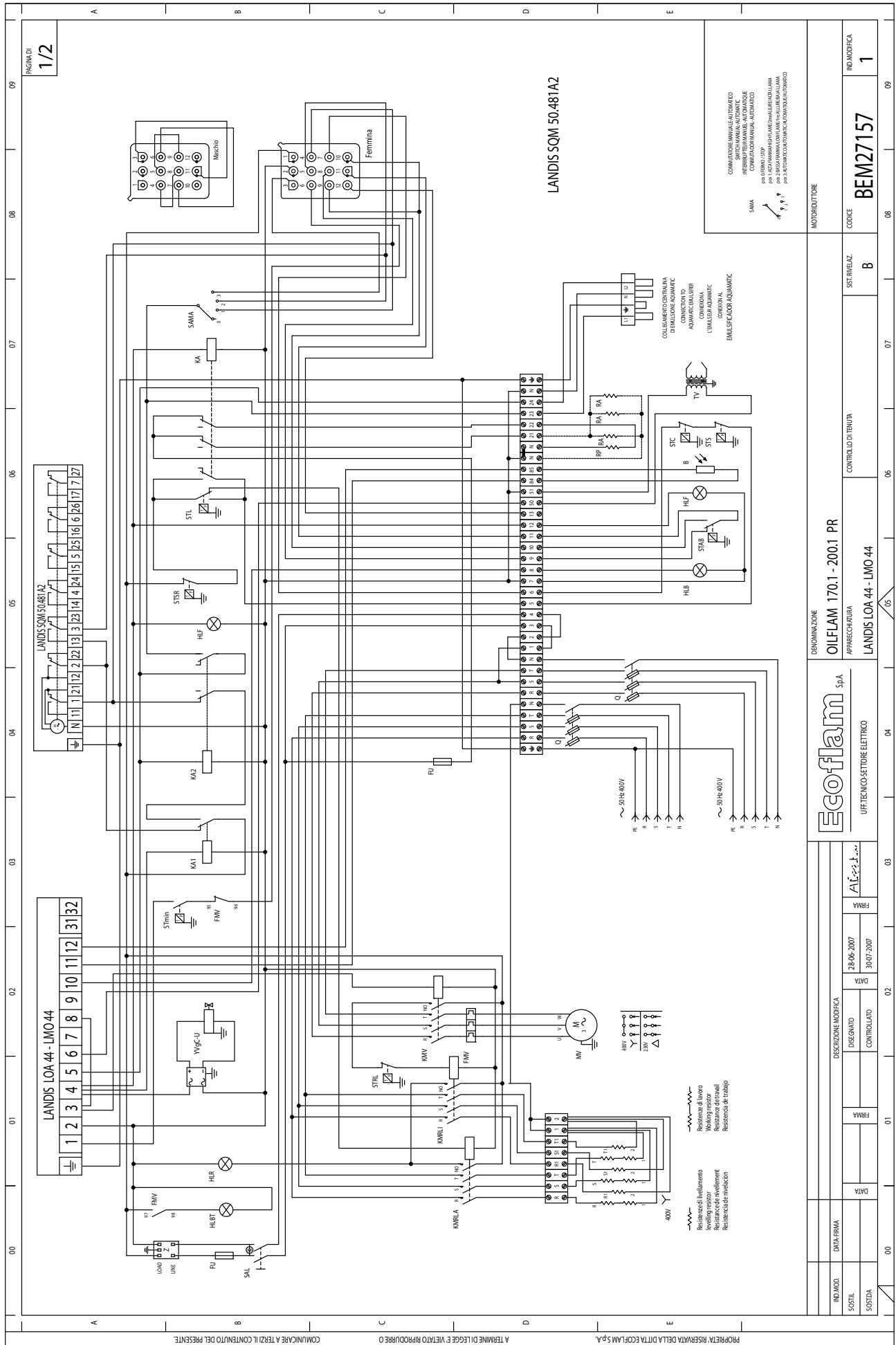

A	B	C	D	E		09	08	07	06	05	04	03	02	01	00																																																																
PAGINA DI 2/2																																																																															
RESISTENZE BARILOTTO OILFLAM RESISTENCES BARILOTS OILFLAM RESISTENCIAS BARILOTOS OILFLAM RESISTENCIA PRECALENTADOR OILFLAM																																																																															
<table border="1" style="width:100%; border-collapse: collapse;"> <thead> <tr> <th>Modello Modelo Modelo</th> <th>Totale Total Total</th> <th>Nivelamento Leveling Nivelacion</th> <th>Lavoro Working Trabajo</th> </tr> </thead> <tbody> <tr> <td>170</td> <td>9000 W</td> <td>4050 W</td> <td>4950 W</td> </tr> <tr> <td>200</td> <td>10500 W</td> <td>4500 W</td> <td>6000 W</td> </tr> </tbody> </table>																Modello Modelo Modelo	Totale Total Total	Nivelamento Leveling Nivelacion	Lavoro Working Trabajo	170	9000 W	4050 W	4950 W	200	10500 W	4500 W	6000 W																																																				
Modello Modelo Modelo	Totale Total Total	Nivelamento Leveling Nivelacion	Lavoro Working Trabajo																																																																												
170	9000 W	4050 W	4950 W																																																																												
200	10500 W	4500 W	6000 W																																																																												
<p>ATTENZIONE: LE RESISTENZE AUSILIARIE "RA" SONO DI SERIE SOLO PER BRUCIATORI OILFLAM 170-200 ABD/0</p> <p>WARNING: THE AUXILIARY RESISTORS "RA" ARE CURRENTLY SUPPLIED WITH OILFLAM 170-200 ABD BURNERS ONLY</p> <p>ATTENTION: LES RESISTANCES AUXILIAIRES "RA" SONT DE SERIE SEULEMENT SUR LES BRULAIURS OILFLAM 170-200 ABD/0</p> <p>CUIDADO: LAS RESISTENCIAS AUXILIARIA "RA" SON DE SERIE SOLO PARA LOS QUEMADORES OILFLAM 170-200 ABD/0</p>																																																																															
<p>(79) I: CAMMA DI REGOLAZIONE ARIA DI MASSIMA (157) II: CAMMA DI REGOLAZIONE ARIA DI ACCENSIONE (307) III: CAMMA DI REGOLAZIONE ARIA DI BASSA (07) IV: CAMMA NON UTILIZZATA (07) V: CAMMA NON UTILIZZATA</p>																																																																															
<table border="1" style="width:100%; border-collapse: collapse;"> <thead> <tr> <th>Modello</th> <th>Resistenza</th> <th>Valore</th> <th>Descrizione</th> </tr> </thead> <tbody> <tr> <td>KW</td> <td>COMUTATORE</td> <td>RESISTENZA</td> <td>COMUTATORE MOTOR VENTILATORE</td> </tr> <tr> <td>SAL</td> <td>INTERRUTTORE</td> <td>RESISTENZA</td> <td>INTERRUTTORE DI LINEA</td> </tr> <tr> <td>STC</td> <td>TERMOSTATO</td> <td>RESISTENZA</td> <td>TERMOSTATO CALDAIA</td> </tr> <tr> <td>STL</td> <td>TERMOSTATO</td> <td>RESISTENZA</td> <td>TERMOSTATO CALORE</td> </tr> <tr> <td>STS</td> <td>TERMOSTATO</td> <td>RESISTENZA</td> <td>TERMOSTATO DI SICUREZZA</td> </tr> <tr> <td>STR1</td> <td>TERMOSTATO</td> <td>RESISTENZA</td> <td>TERMOSTATO DI SICUREZZA</td> </tr> <tr> <td>STR</td> <td>TERMOSTATO</td> <td>RESISTENZA</td> <td>TERMOSTATO DI SICUREZZA</td> </tr> <tr> <td>KM1RA</td> <td>COMUTATORE</td> <td>RESISTENZA</td> <td>COMUTATORE RESISTENZE DI LAVORO</td> </tr> <tr> <td>KM1R1</td> <td>COMUTATORE</td> <td>RESISTENZA</td> <td>COMUTATORE RESISTENZE DI LIVELLAMENTO</td> </tr> <tr> <td>S7min</td> <td>TERMOSTATO</td> <td>RESISTENZA</td> <td>TERMOSTATO DIMINUIA</td> </tr> <tr> <td>Y9GCU</td> <td>SOLENOIDE</td> <td>RESISTENZA</td> <td>SOLENOIDE CHIUSURA UGELLO</td> </tr> <tr> <td>HLBT</td> <td>LAMPADA</td> <td>RESISTENZA</td> <td>LAMPADA DI BLOCCO TERMICO</td> </tr> <tr> <td>STAB</td> <td>TERMOSTATO</td> <td>RESISTENZA</td> <td>TERMOSTATO DI ALTA BASSA FIAMMA</td> </tr> </tbody> </table>																Modello	Resistenza	Valore	Descrizione	KW	COMUTATORE	RESISTENZA	COMUTATORE MOTOR VENTILATORE	SAL	INTERRUTTORE	RESISTENZA	INTERRUTTORE DI LINEA	STC	TERMOSTATO	RESISTENZA	TERMOSTATO CALDAIA	STL	TERMOSTATO	RESISTENZA	TERMOSTATO CALORE	STS	TERMOSTATO	RESISTENZA	TERMOSTATO DI SICUREZZA	STR1	TERMOSTATO	RESISTENZA	TERMOSTATO DI SICUREZZA	STR	TERMOSTATO	RESISTENZA	TERMOSTATO DI SICUREZZA	KM1RA	COMUTATORE	RESISTENZA	COMUTATORE RESISTENZE DI LAVORO	KM1R1	COMUTATORE	RESISTENZA	COMUTATORE RESISTENZE DI LIVELLAMENTO	S7min	TERMOSTATO	RESISTENZA	TERMOSTATO DIMINUIA	Y9GCU	SOLENOIDE	RESISTENZA	SOLENOIDE CHIUSURA UGELLO	HLBT	LAMPADA	RESISTENZA	LAMPADA DI BLOCCO TERMICO	STAB	TERMOSTATO	RESISTENZA	TERMOSTATO DI ALTA BASSA FIAMMA								
Modello	Resistenza	Valore	Descrizione																																																																												
KW	COMUTATORE	RESISTENZA	COMUTATORE MOTOR VENTILATORE																																																																												
SAL	INTERRUTTORE	RESISTENZA	INTERRUTTORE DI LINEA																																																																												
STC	TERMOSTATO	RESISTENZA	TERMOSTATO CALDAIA																																																																												
STL	TERMOSTATO	RESISTENZA	TERMOSTATO CALORE																																																																												
STS	TERMOSTATO	RESISTENZA	TERMOSTATO DI SICUREZZA																																																																												
STR1	TERMOSTATO	RESISTENZA	TERMOSTATO DI SICUREZZA																																																																												
STR	TERMOSTATO	RESISTENZA	TERMOSTATO DI SICUREZZA																																																																												
KM1RA	COMUTATORE	RESISTENZA	COMUTATORE RESISTENZE DI LAVORO																																																																												
KM1R1	COMUTATORE	RESISTENZA	COMUTATORE RESISTENZE DI LIVELLAMENTO																																																																												
S7min	TERMOSTATO	RESISTENZA	TERMOSTATO DIMINUIA																																																																												
Y9GCU	SOLENOIDE	RESISTENZA	SOLENOIDE CHIUSURA UGELLO																																																																												
HLBT	LAMPADA	RESISTENZA	LAMPADA DI BLOCCO TERMICO																																																																												
STAB	TERMOSTATO	RESISTENZA	TERMOSTATO DI ALTA BASSA FIAMMA																																																																												
<table border="1" style="width:100%; border-collapse: collapse;"> <thead> <tr> <th>Modello</th> <th>Resistenza</th> <th>Valore</th> <th>Descrizione</th> </tr> </thead> <tbody> <tr> <td>B</td> <td>FOTORESISTENZA</td> <td>RESISTENZA</td> <td>FOTORESISTENZA</td> </tr> <tr> <td>Q</td> <td>INTERRUTTORE</td> <td>RESISTENZA</td> <td>INTERRUTTORE GENERALE CON FUSIBILE</td> </tr> <tr> <td>Z</td> <td>FILTRO</td> <td>RESISTENZA</td> <td>FILTRO ANTIPARASITIS</td> </tr> <tr> <td>FU</td> <td>FUSIBILE</td> <td>RESISTENZA</td> <td>FUSIBILE</td> </tr> <tr> <td>KA</td> <td>RELE'</td> <td>RESISTENZA</td> <td>RELE'</td> </tr> <tr> <td>KA1</td> <td>RELE'</td> <td>RESISTENZA</td> <td>RELE'</td> </tr> <tr> <td>KA2</td> <td>RELE'</td> <td>RESISTENZA</td> <td>RELE'</td> </tr> <tr> <td>MV</td> <td>MOTORE</td> <td>RESISTENZA</td> <td>MOTORE VENTILATORE</td> </tr> <tr> <td>RA</td> <td>RESISTENZA</td> <td>RESISTENZA</td> <td>RESISTENZA AUSILIARIA</td> </tr> <tr> <td>RP</td> <td>RESISTENZA</td> <td>RESISTENZA</td> <td>RESISTENZA POMPA</td> </tr> <tr> <td>TV</td> <td>TRASFORMATORE</td> <td>RESISTENZA</td> <td>TRASFORMATORE</td> </tr> <tr> <td>FMV</td> <td>RELE'</td> <td>RESISTENZA</td> <td>RELE' TERMICO</td> </tr> <tr> <td>HLB</td> <td>LAMPADA</td> <td>RESISTENZA</td> <td>LAMPADA DI BLOCCO</td> </tr> <tr> <td>HLF</td> <td>LAMPADA</td> <td>RESISTENZA</td> <td>LAMPADA DI FUNZIONAMENTO</td> </tr> <tr> <td>HLR</td> <td>LAMPADA</td> <td>RESISTENZA</td> <td>LAMPADA</td> </tr> </tbody> </table>																Modello	Resistenza	Valore	Descrizione	B	FOTORESISTENZA	RESISTENZA	FOTORESISTENZA	Q	INTERRUTTORE	RESISTENZA	INTERRUTTORE GENERALE CON FUSIBILE	Z	FILTRO	RESISTENZA	FILTRO ANTIPARASITIS	FU	FUSIBILE	RESISTENZA	FUSIBILE	KA	RELE'	RESISTENZA	RELE'	KA1	RELE'	RESISTENZA	RELE'	KA2	RELE'	RESISTENZA	RELE'	MV	MOTORE	RESISTENZA	MOTORE VENTILATORE	RA	RESISTENZA	RESISTENZA	RESISTENZA AUSILIARIA	RP	RESISTENZA	RESISTENZA	RESISTENZA POMPA	TV	TRASFORMATORE	RESISTENZA	TRASFORMATORE	FMV	RELE'	RESISTENZA	RELE' TERMICO	HLB	LAMPADA	RESISTENZA	LAMPADA DI BLOCCO	HLF	LAMPADA	RESISTENZA	LAMPADA DI FUNZIONAMENTO	HLR	LAMPADA	RESISTENZA	LAMPADA
Modello	Resistenza	Valore	Descrizione																																																																												
B	FOTORESISTENZA	RESISTENZA	FOTORESISTENZA																																																																												
Q	INTERRUTTORE	RESISTENZA	INTERRUTTORE GENERALE CON FUSIBILE																																																																												
Z	FILTRO	RESISTENZA	FILTRO ANTIPARASITIS																																																																												
FU	FUSIBILE	RESISTENZA	FUSIBILE																																																																												
KA	RELE'	RESISTENZA	RELE'																																																																												
KA1	RELE'	RESISTENZA	RELE'																																																																												
KA2	RELE'	RESISTENZA	RELE'																																																																												
MV	MOTORE	RESISTENZA	MOTORE VENTILATORE																																																																												
RA	RESISTENZA	RESISTENZA	RESISTENZA AUSILIARIA																																																																												
RP	RESISTENZA	RESISTENZA	RESISTENZA POMPA																																																																												
TV	TRASFORMATORE	RESISTENZA	TRASFORMATORE																																																																												
FMV	RELE'	RESISTENZA	RELE' TERMICO																																																																												
HLB	LAMPADA	RESISTENZA	LAMPADA DI BLOCCO																																																																												
HLF	LAMPADA	RESISTENZA	LAMPADA DI FUNZIONAMENTO																																																																												
HLR	LAMPADA	RESISTENZA	LAMPADA																																																																												
<table border="1" style="width:100%; border-collapse: collapse;"> <thead> <tr> <th>Modello</th> <th>Resistenza</th> <th>Valore</th> <th>Descrizione</th> </tr> </thead> <tbody> <tr> <td>DATA-FIRMA</td> <td>DATA-FIRMA</td> <td>DATA-FIRMA</td> <td>DATA-FIRMA</td> </tr> <tr> <td>DISCUSSIONE MODIFICA</td> <td>DISCUSSIONE MODIFICA</td> <td>DISCUSSIONE MODIFICA</td> <td>DISCUSSIONE MODIFICA</td> </tr> <tr> <td>DESIGNATO</td> <td>DESIGNATO</td> <td>DESIGNATO</td> <td>DESIGNATO</td> </tr> <tr> <td>CONTROLATO</td> <td>CONTROLATO</td> <td>CONTROLATO</td> <td>CONTROLATO</td> </tr> <tr> <td>DATA</td> <td>DATA</td> <td>DATA</td> <td>DATA</td> </tr> <tr> <td>DATA</td> <td>DATA</td> <td>DATA</td> <td>DATA</td> </tr> </tbody> </table>																Modello	Resistenza	Valore	Descrizione	DATA-FIRMA	DATA-FIRMA	DATA-FIRMA	DATA-FIRMA	DISCUSSIONE MODIFICA	DISCUSSIONE MODIFICA	DISCUSSIONE MODIFICA	DISCUSSIONE MODIFICA	DESIGNATO	DESIGNATO	DESIGNATO	DESIGNATO	CONTROLATO	CONTROLATO	CONTROLATO	CONTROLATO	DATA	DATA	DATA	DATA	DATA	DATA	DATA	DATA																																				
Modello	Resistenza	Valore	Descrizione																																																																												
DATA-FIRMA	DATA-FIRMA	DATA-FIRMA	DATA-FIRMA																																																																												
DISCUSSIONE MODIFICA	DISCUSSIONE MODIFICA	DISCUSSIONE MODIFICA	DISCUSSIONE MODIFICA																																																																												
DESIGNATO	DESIGNATO	DESIGNATO	DESIGNATO																																																																												
CONTROLATO	CONTROLATO	CONTROLATO	CONTROLATO																																																																												
DATA	DATA	DATA	DATA																																																																												
DATA	DATA	DATA	DATA																																																																												
<table border="1" style="width:100%; border-collapse: collapse;"> <thead> <tr> <th>Modello</th> <th>Resistenza</th> <th>Valore</th> <th>Descrizione</th> </tr> </thead> <tbody> <tr> <td>IND. MOD.</td> <td>IND. MOD.</td> <td>IND. MOD.</td> <td>IND. MOD.</td> </tr> <tr> <td>SOST. I.</td> <td>SOST. I.</td> <td>SOST. I.</td> <td>SOST. I.</td> </tr> <tr> <td>SOST. DA</td> <td>SOST. DA</td> <td>SOST. DA</td> <td>SOST. DA</td> </tr> </tbody> </table>																Modello	Resistenza	Valore	Descrizione	IND. MOD.	IND. MOD.	IND. MOD.	IND. MOD.	SOST. I.	SOST. I.	SOST. I.	SOST. I.	SOST. DA	SOST. DA	SOST. DA	SOST. DA																																																
Modello	Resistenza	Valore	Descrizione																																																																												
IND. MOD.	IND. MOD.	IND. MOD.	IND. MOD.																																																																												
SOST. I.	SOST. I.	SOST. I.	SOST. I.																																																																												
SOST. DA	SOST. DA	SOST. DA	SOST. DA																																																																												
<table border="1" style="width:100%; border-collapse: collapse;"> <thead> <tr> <th>Modello</th> <th>Resistenza</th> <th>Valore</th> <th>Descrizione</th> </tr> </thead> <tbody> <tr> <td>DATA-FIRMA</td> <td>DATA-FIRMA</td> <td>DATA-FIRMA</td> <td>DATA-FIRMA</td> </tr> <tr> <td>DISCUSSIONE MODIFICA</td> <td>DISCUSSIONE MODIFICA</td> <td>DISCUSSIONE MODIFICA</td> <td>DISCUSSIONE MODIFICA</td> </tr> <tr> <td>DESIGNATO</td> <td>DESIGNATO</td> <td>DESIGNATO</td> <td>DESIGNATO</td> </tr> <tr> <td>CONTROLATO</td> <td>CONTROLATO</td> <td>CONTROLATO</td> <td>CONTROLATO</td> </tr> <tr> <td>DATA</td> <td>DATA</td> <td>DATA</td> <td>DATA</td> </tr> <tr> <td>DATA</td> <td>DATA</td> <td>DATA</td> <td>DATA</td> </tr> </tbody> </table>																Modello	Resistenza	Valore	Descrizione	DATA-FIRMA	DATA-FIRMA	DATA-FIRMA	DATA-FIRMA	DISCUSSIONE MODIFICA	DISCUSSIONE MODIFICA	DISCUSSIONE MODIFICA	DISCUSSIONE MODIFICA	DESIGNATO	DESIGNATO	DESIGNATO	DESIGNATO	CONTROLATO	CONTROLATO	CONTROLATO	CONTROLATO	DATA	DATA	DATA	DATA	DATA	DATA	DATA	DATA																																				
Modello	Resistenza	Valore	Descrizione																																																																												
DATA-FIRMA	DATA-FIRMA	DATA-FIRMA	DATA-FIRMA																																																																												
DISCUSSIONE MODIFICA	DISCUSSIONE MODIFICA	DISCUSSIONE MODIFICA	DISCUSSIONE MODIFICA																																																																												
DESIGNATO	DESIGNATO	DESIGNATO	DESIGNATO																																																																												
CONTROLATO	CONTROLATO	CONTROLATO	CONTROLATO																																																																												
DATA	DATA	DATA	DATA																																																																												
DATA	DATA	DATA	DATA																																																																												
<table border="1" style="width:100%; border-collapse: collapse;"> <thead> <tr> <th>Modello</th> <th>Resistenza</th> <th>Valore</th> <th>Descrizione</th> </tr> </thead> <tbody> <tr> <td>DATA-FIRMA</td> <td>DATA-FIRMA</td> <td>DATA-FIRMA</td> <td>DATA-FIRMA</td> </tr> <tr> <td>DISCUSSIONE MODIFICA</td> <td>DISCUSSIONE MODIFICA</td> <td>DISCUSSIONE MODIFICA</td> <td>DISCUSSIONE MODIFICA</td> </tr> <tr> <td>DESIGNATO</td> <td>DESIGNATO</td> <td>DESIGNATO</td> <td>DESIGNATO</td> </tr> <tr> <td>CONTROLATO</td> <td>CONTROLATO</td> <td>CONTROLATO</td> <td>CONTROLATO</td> </tr> <tr> <td>DATA</td> <td>DATA</td> <td>DATA</td> <td>DATA</td> </tr> <tr> <td>DATA</td> <td>DATA</td> <td>DATA</td> <td>DATA</td> </tr> </tbody> </table>																Modello	Resistenza	Valore	Descrizione	DATA-FIRMA	DATA-FIRMA	DATA-FIRMA	DATA-FIRMA	DISCUSSIONE MODIFICA	DISCUSSIONE MODIFICA	DISCUSSIONE MODIFICA	DISCUSSIONE MODIFICA	DESIGNATO	DESIGNATO	DESIGNATO	DESIGNATO	CONTROLATO	CONTROLATO	CONTROLATO	CONTROLATO	DATA	DATA	DATA	DATA	DATA	DATA	DATA	DATA																																				
Modello	Resistenza	Valore	Descrizione																																																																												
DATA-FIRMA	DATA-FIRMA	DATA-FIRMA	DATA-FIRMA																																																																												
DISCUSSIONE MODIFICA	DISCUSSIONE MODIFICA	DISCUSSIONE MODIFICA	DISCUSSIONE MODIFICA																																																																												
DESIGNATO	DESIGNATO	DESIGNATO	DESIGNATO																																																																												
CONTROLATO	CONTROLATO	CONTROLATO	CONTROLATO																																																																												
DATA	DATA	DATA	DATA																																																																												
DATA	DATA	DATA	DATA																																																																												
<table border="1" style="width:100%; border-collapse: collapse;"> <thead> <tr> <th>Modello</th> <th>Resistenza</th> <th>Valore</th> <th>Descrizione</th> </tr> </thead> <tbody> <tr> <td>DATA-FIRMA</td> <td>DATA-FIRMA</td> <td>DATA-FIRMA</td> <td>DATA-FIRMA</td> </tr> <tr> <td>DISCUSSIONE MODIFICA</td> <td>DISCUSSIONE MODIFICA</td> <td>DISCUSSIONE MODIFICA</td> <td>DISCUSSIONE MODIFICA</td> </tr> <tr> <td>DESIGNATO</td> <td>DESIGNATO</td> <td>DESIGNATO</td> <td>DESIGNATO</td> </tr> <tr> <td>CONTROLATO</td> <td>CONTROLATO</td> <td>CONTROLATO</td> <td>CONTROLATO</td> </tr> <tr> <td>DATA</td> <td>DATA</td> <td>DATA</td> <td>DATA</td> </tr> <tr> <td>DATA</td> <td>DATA</td> <td>DATA</td> <td>DATA</td> </tr> </tbody> </table>																Modello	Resistenza	Valore	Descrizione	DATA-FIRMA	DATA-FIRMA	DATA-FIRMA	DATA-FIRMA	DISCUSSIONE MODIFICA	DISCUSSIONE MODIFICA	DISCUSSIONE MODIFICA	DISCUSSIONE MODIFICA	DESIGNATO	DESIGNATO	DESIGNATO	DESIGNATO	CONTROLATO	CONTROLATO	CONTROLATO	CONTROLATO	DATA	DATA	DATA	DATA	DATA	DATA	DATA	DATA																																				
Modello	Resistenza	Valore	Descrizione																																																																												
DATA-FIRMA	DATA-FIRMA	DATA-FIRMA	DATA-FIRMA																																																																												
DISCUSSIONE MODIFICA	DISCUSSIONE MODIFICA	DISCUSSIONE MODIFICA	DISCUSSIONE MODIFICA																																																																												
DESIGNATO	DESIGNATO	DESIGNATO	DESIGNATO																																																																												
CONTROLATO	CONTROLATO	CONTROLATO	CONTROLATO																																																																												
DATA	DATA	DATA	DATA																																																																												
DATA	DATA	DATA	DATA																																																																												
<table border="1" style="width:100%; border-collapse: collapse;"> <thead> <tr> <th>Modello</th> <th>Resistenza</th> <th>Valore</th> <th>Descrizione</th> </tr> </thead> <tbody> <tr> <td>DATA-FIRMA</td> <td>DATA-FIRMA</td> <td>DATA-FIRMA</td> <td>DATA-FIRMA</td> </tr> <tr> <td>DISCUSSIONE MODIFICA</td> <td>DISCUSSIONE MODIFICA</td> <td>DISCUSSIONE MODIFICA</td> <td>DISCUSSIONE MODIFICA</td> </tr> <tr> <td>DESIGNATO</td> <td>DESIGNATO</td> <td>DESIGNATO</td> <td>DESIGNATO</td> </tr> <tr> <td>CONTROLATO</td> <td>CONTROLATO</td> <td>CONTROLATO</td> <td>CONTROLATO</td> </tr> <tr> <td>DATA</td> <td>DATA</td> <td>DATA</td> <td>DATA</td> </tr> <tr> <td>DATA</td> <td>DATA</td> <td>DATA</td> <td>DATA</td> </tr> </tbody> </table>																Modello	Resistenza	Valore	Descrizione	DATA-FIRMA	DATA-FIRMA	DATA-FIRMA	DATA-FIRMA	DISCUSSIONE MODIFICA	DISCUSSIONE MODIFICA	DISCUSSIONE MODIFICA	DISCUSSIONE MODIFICA	DESIGNATO	DESIGNATO	DESIGNATO	DESIGNATO	CONTROLATO	CONTROLATO	CONTROLATO	CONTROLATO	DATA	DATA	DATA	DATA	DATA	DATA	DATA	DATA																																				
Modello	Resistenza	Valore	Descrizione																																																																												
DATA-FIRMA	DATA-FIRMA	DATA-FIRMA	DATA-FIRMA																																																																												
DISCUSSIONE MODIFICA	DISCUSSIONE MODIFICA	DISCUSSIONE MODIFICA	DISCUSSIONE MODIFICA																																																																												
DESIGNATO	DESIGNATO	DESIGNATO	DESIGNATO																																																																												
CONTROLATO	CONTROLATO	CONTROLATO	CONTROLATO																																																																												
DATA	DATA	DATA	DATA																																																																												
DATA	DATA	DATA	DATA																																																																												
<table border="1" style="width:100%; border-collapse: collapse;"> <thead> <tr> <th>Modello</th> <th>Resistenza</th> <th>Valore</th> <th>Descrizione</th> </tr> </thead> <tbody> <tr> <td>DATA-FIRMA</td> <td>DATA-FIRMA</td> <td>DATA-FIRMA</td> <td>DATA-FIRMA</td> </tr> <tr> <td>DISCUSSIONE MODIFICA</td> <td>DISCUSSIONE MODIFICA</td> <td>DISCUSSIONE MODIFICA</td> <td>DISCUSSIONE MODIFICA</td> </tr> <tr> <td>DESIGNATO</td> <td>DESIGNATO</td> <td>DESIGNATO</td> <td>DESIGNATO</td> </tr> <tr> <td>CONTROLATO</td> <td>CONTROLATO</td> <td>CONTROLATO</td> <td>CONTROLATO</td> </tr> <tr> <td>DATA</td> <td>DATA</td> <td>DATA</td> <td>DATA</td> </tr> <tr> <td>DATA</td> <td>DATA</td> <td>DATA</td> <td>DATA</td> </tr> </tbody> </table>																Modello	Resistenza	Valore	Descrizione	DATA-FIRMA	DATA-FIRMA	DATA-FIRMA	DATA-FIRMA	DISCUSSIONE MODIFICA	DISCUSSIONE MODIFICA	DISCUSSIONE MODIFICA	DISCUSSIONE MODIFICA	DESIGNATO	DESIGNATO	DESIGNATO	DESIGNATO	CONTROLATO	CONTROLATO	CONTROLATO	CONTROLATO	DATA	DATA	DATA	DATA	DATA	DATA	DATA	DATA																																				
Modello	Resistenza	Valore	Descrizione																																																																												
DATA-FIRMA	DATA-FIRMA	DATA-FIRMA	DATA-FIRMA																																																																												
DISCUSSIONE MODIFICA	DISCUSSIONE MODIFICA	DISCUSSIONE MODIFICA	DISCUSSIONE MODIFICA																																																																												
DESIGNATO	DESIGNATO	DESIGNATO	DESIGNATO																																																																												
CONTROLATO	CONTROLATO	CONTROLATO	CONTROLATO																																																																												
DATA	DATA	DATA	DATA																																																																												
DATA	DATA	DATA	DATA																																																																												
<table border="1" style="width:100%; border-collapse: collapse;"> <thead> <tr> <th>Modello</th> <th>Resistenza</th> <th>Valore</th> <th>Descrizione</th> </tr> </thead> <tbody> <tr> <td>DATA-FIRMA</td> <td>DATA-FIRMA</td> <td>DATA-FIRMA</td> <td>DATA-FIRMA</td> </tr> <tr> <td>DISCUSSIONE MODIFICA</td> <td>DISCUSSIONE MODIFICA</td> <td>DISCUSSIONE MODIFICA</td> <td>DISCUSSIONE MODIFICA</td> </tr> <tr> <td>DESIGNATO</td> <td>DESIGNATO</td> <td>DESIGNATO</td> <td>DESIGNATO</td> </tr> <tr> <td>CONTROLATO</td> <td>CONTROLATO</td> <td>CONTROLATO</td> <td>CONTROLATO</td> </tr> <tr> <td>DATA</td> <td>DATA</td> <td>DATA</td> <td>DATA</td> </tr> <tr> <td>DATA</td> <td>DATA</td> <td>DATA</td> <td>DATA</td> </tr> </tbody> </table>																Modello	Resistenza	Valore	Descrizione	DATA-FIRMA	DATA-FIRMA	DATA-FIRMA	DATA-FIRMA	DISCUSSIONE MODIFICA	DISCUSSIONE MODIFICA	DISCUSSIONE MODIFICA	DISCUSSIONE MODIFICA	DESIGNATO	DESIGNATO	DESIGNATO	DESIGNATO	CONTROLATO	CONTROLATO	CONTROLATO	CONTROLATO	DATA	DATA	DATA	DATA	DATA	DATA	DATA	DATA																																				
Modello	Resistenza	Valore	Descrizione																																																																												
DATA-FIRMA	DATA-FIRMA	DATA-FIRMA	DATA-FIRMA																																																																												
DISCUSSIONE MODIFICA	DISCUSSIONE MODIFICA	DISCUSSIONE MODIFICA	DISCUSSIONE MODIFICA																																																																												
DESIGNATO	DESIGNATO	DESIGNATO	DESIGNATO																																																																												
CONTROLATO	CONTROLATO	CONTROLATO	CONTROLATO																																																																												
DATA	DATA	DATA	DATA																																																																												
DATA	DATA	DATA	DATA																																																																												
<table border="1" style="width:100%; border-collapse: collapse;"> <thead> <tr> <th>Modello</th> <th>Resistenza</th> <th>Valore</th> <th>Descrizione</th> </tr> </thead> <tbody> <tr> <td>DATA-FIRMA</td> <td>DATA-FIRMA</td> <td>DATA-FIRMA</td> <td>DATA-FIRMA</td> </tr> <tr> <td>DISCUSSIONE MODIFICA</td> <td>DISCUSSIONE MODIFICA</td> <td>DISCUSSIONE MODIFICA</td> <td>DISCUSSIONE MODIFICA</td> </tr> <tr> <td>DESIGNATO</td> <td>DESIGNATO</td> <td>DESIGNATO</td> <td>DESIGNATO</td> </tr> <tr> <td>CONTROLATO</td> <td>CONTROLATO</td> <td>CONTROLATO</td> <td>CONTROLATO</td> </tr> <tr> <td>DATA</td> <td>DATA</td> <td>DATA</td> <td>DATA</td> </tr> <tr> <td>DATA</td> <td>DATA</td> <td>DATA</td> <td>DATA</td> </tr> </tbody> </table>																Modello	Resistenza	Valore	Descrizione	DATA-FIRMA	DATA-FIRMA	DATA-FIRMA	DATA-FIRMA	DISCUSSIONE MODIFICA	DISCUSSIONE MODIFICA	DISCUSSIONE MODIFICA	DISCUSSIONE MODIFICA	DESIGNATO	DESIGNATO	DESIGNATO	DESIGNATO	CONTROLATO	CONTROLATO	CONTROLATO	CONTROLATO	DATA	DATA	DATA	DATA	DATA	DATA	DATA	DATA																																				
Modello	Resistenza	Valore	Descrizione																																																																												
DATA-FIRMA	DATA-FIRMA	DATA-FIRMA	DATA-FIRMA																																																																												
DISCUSSIONE MODIFICA	DISCUSSIONE MODIFICA	DISCUSSIONE MODIFICA	DISCUSSIONE MODIFICA																																																																												
DESIGNATO	DESIGNATO	DESIGNATO	DESIGNATO																																																																												
CONTROLATO	CONTROLATO	CONTROLATO	CONTROLATO																																																																												
DATA	DATA	DATA	DATA																																																																												
DATA	DATA	DATA	DATA																																																																												
<table border="1" style="width:100%; border-collapse: collapse;"> <thead> <tr> <th>Modello</th> <th>Resistenza</th> <th>Valore</th> <th>Descrizione</th> </tr> </thead> <tbody> <tr> <td>DATA-FIRMA</td> <td>DATA-FIRMA</td> <td>DATA-FIRMA</td> <td>DATA-FIRMA</td> </tr> <tr> <td>DISCUSSIONE MODIFICA</td> <td>DISCUSSIONE MODIFICA</td> <td>DISCUSSIONE MODIFICA</td> <td>DISCUSSIONE MODIFICA</td> </tr> <tr> <td>DESIGNATO</td> <td>DESIGNATO</td> <td>DESIGNATO</td> <td>DESIGNATO</td> </tr> <tr> <td>CONTROLATO</td> <td>CONTROLATO</td> <td>CONTROLATO</td> <td>CONTROLATO</td> </tr> <tr> <td>DATA</td> <td>DATA</td> <td>DATA</td> <td>DATA</td> </tr> <tr> <td>DATA</td> <td>DATA</td> <td>DATA</td> <td>DATA</td> </tr> </tbody> </table>																Modello	Resistenza	Valore	Descrizione	DATA-FIRMA	DATA-FIRMA	DATA-FIRMA	DATA-FIRMA	DISCUSSIONE MODIFICA	DISCUSSIONE MODIFICA	DISCUSSIONE MODIFICA	DISCUSSIONE MODIFICA	DESIGNATO	DESIGNATO	DESIGNATO	DESIGNATO	CONTROLATO	CONTROLATO	CONTROLATO	CONTROLATO	DATA	DATA	DATA	DATA	DATA	DATA	DATA	DATA																																				
Modello	Resistenza	Valore	Descrizione																																																																												
DATA-FIRMA	DATA-FIRMA	DATA-FIRMA	DATA-FIRMA																																																																												
DISCUSSIONE MODIFICA	DISCUSSIONE MODIFICA	DISCUSSIONE MODIFICA	DISCUSSIONE MODIFICA																																																																												
DESIGNATO	DESIGNATO	DESIGNATO	DESIGNATO																																																																												
CONTROLATO	CONTROLATO	CONTROLATO	CONTROLATO																																																																												
DATA	DATA	DATA	DATA																																																																												
DATA	DATA	DATA	DATA																																																																												
<table border="1" style="width:100%; border-collapse: collapse;"> <thead> <tr> <th>Modello</th> <th>Resistenza</th> <th>Valore</th> <th>Descrizione</th> </tr> </thead> <tbody> <tr> <td>DATA-FIRMA</td> <td>DATA-FIRMA</td> <td>DATA-FIRMA</td> <td>DATA-FIRMA</td> </tr> <tr> <td>DISCUSSIONE MODIFICA</td> <td>DISCUSSIONE MODIFICA</td> <td>DISCUSSIONE MODIFICA</td> <td>DISCUSSIONE MODIFICA</td> </tr> <tr> <td>DESIGNATO</td> <td>DESIGNATO</td> <td>DESIGNATO</td> <td>DESIGNATO</td> </tr> <tr> <td>CONTROLATO</td> <td>CONTROLATO</td> <td>CONTROLATO</td> <td>CONTROLATO</td> </tr> <tr> <td>DATA</td> <td>DATA</td> <td>DATA</td> <td>DATA</td> </tr> <tr> <td>DATA</td> <td>DATA</td> <td>DATA</td> <td>DATA</td> </tr> </tbody> </table>																Modello	Resistenza	Valore	Descrizione	DATA-FIRMA	DATA-FIRMA	DATA-FIRMA	DATA-FIRMA	DISCUSSIONE MODIFICA	DISCUSSIONE MODIFICA	DISCUSSIONE MODIFICA	DISCUSSIONE MODIFICA	DESIGNATO	DESIGNATO	DESIGNATO	DESIGNATO	CONTROLATO	CONTROLATO	CONTROLATO	CONTROLATO	DATA	DATA	DATA	DATA	DATA	DATA	DATA	DATA																																				
Modello	Resistenza	Valore	Descrizione																																																																												
DATA-FIRMA	DATA-FIRMA	DATA-FIRMA	DATA-FIRMA																																																																												
DISCUSSIONE MODIFICA	DISCUSSIONE MODIFICA	DISCUSSIONE MODIFICA	DISCUSSIONE MODIFICA																																																																												
DESIGNATO	DESIGNATO	DESIGNATO	DESIGNATO																																																																												
CONTROLATO	CONTROLATO	CONTROLATO	CONTROLATO																																																																												
DATA	DATA	DATA	DATA																																																																												
DATA	DATA	DATA	DATA																																																																												
<table border="1" style="width:100%; border-collapse: collapse;"> <thead> <tr> <th>Modello</th> <th>Resistenza</th> <th>Valore</th> <th>Descrizione</th> </tr> </thead> <tbody> <tr> <td>DATA-FIRMA</td> <td>DATA-FIRMA</td> <td>DATA-FIRMA</td> <td>DATA-FIRMA</td> </tr> <tr> <td>DISCUSSIONE MODIFICA</td> <td>DISCUSSIONE MODIFICA</td> <td>DISCUSSIONE MODIFICA</td> <td>DISCUSSIONE MODIFICA</td> </tr> <tr> <td>DESIGNATO</td> <td>DESIGNATO</td> <td>DESIGNATO</td> <td>DESIGNATO</td> </tr> <tr> <td>CONTROLATO</td> <td>CONTROLATO</td> <td>CONTROLATO</td> <td>CONTROLATO</td> </tr> <tr> <td>DATA</td> <td>DATA</td> <td>DATA</td> <td>DATA</td> </tr> <tr> <td>DATA</td> <td>DATA</td> <td>DATA</td> <td>DATA</td> </tr> </tbody> </table>																Modello	Resistenza	Valore	Descrizione	DATA-FIRMA	DATA-FIRMA	DATA-FIRMA	DATA-FIRMA	DISCUSSIONE MODIFICA	DISCUSSIONE MODIFICA	DISCUSSIONE MODIFICA	DISCUSSIONE MODIFICA	DESIGNATO	DESIGNATO	DESIGNATO	DESIGNATO	CONTROLATO	CONTROLATO	CONTROLATO	CONTROLATO	DATA	DATA	DATA	DATA	DATA	DATA	DATA	DATA																																				
Modello	Resistenza	Valore	Descrizione																																																																												
DATA-FIRMA	DATA-FIRMA	DATA-FIRMA	DATA-FIRMA																																																																												
DISCUSSIONE MODIFICA	DISCUSSIONE MODIFICA	DISCUSSIONE MODIFICA	DISCUSSIONE MODIFICA																																																																												
DESIGNATO	DESIGNATO	DESIGNATO	DESIGNATO																																																																												
CONTROLATO	CONTROLATO	CONTROLATO	CONTROLATO																																																																												
DATA	DATA	DATA	DATA																																																																												
DATA	DATA	DATA	DATA																																																																												
<table border="1" style="width:100%; border-collapse: collapse;"> <thead> <tr> <th>Modello</th> <th>Resistenza</th> <th>Valore</th> <th>Descrizione</th> </tr> </thead> <tbody> <tr> <td>DATA-FIRMA</td> <td>DATA-FIRMA</td> <td>DATA-FIRMA</td> <td>DATA-FIRMA</td> </tr> <tr> <td>DISCUSSIONE MODIFICA</td> <td>DISCUSSIONE MODIFICA</td> <td>DISCUSSIONE MODIFICA</td> <td>DISCUSSIONE MODIFICA</td> </tr> <tr> <td>DESIGNATO</td> <td>DESIGNATO</td> <td>DESIGNATO</td> <td>DESIGNATO</td> </tr> <tr> <td>CONTROLATO</td> <td>CONTROLATO</td> <td>CONTROLATO</td> <td>CONTROLATO</td> </tr> <tr> <td>DATA</td> <td>DATA</td> <td>DATA</td> <td>DATA</td> </tr> <tr> <td>DATA</td> <td>DATA</td> <td>DATA</td> <td>DATA</td> </tr> </tbody> </table>																Modello	Resistenza	Valore	Descrizione	DATA-FIRMA	DATA-FIRMA	DATA-FIRMA	DATA-FIRMA	DISCUSSIONE MODIFICA	DISCUSSIONE MODIFICA	DISCUSSIONE MODIFICA	DISCUSSIONE MODIFICA	DESIGNATO	DESIGNATO	DESIGNATO	DESIGNATO	CONTROLATO	CONTROLATO	CONTROLATO	CONTROLATO	DATA	DATA	DATA	DATA	DATA	DATA	DATA	DATA																																				
Modello	Resistenza	Valore	Descrizione																																																																												
DATA-FIRMA	DATA-FIRMA	DATA-FIRMA	DATA-FIRMA																																																																												
DISCUSSIONE MODIFICA	DISCUSSIONE MODIFICA	DISCUSSIONE MODIFICA	DISCUSSIONE MODIFICA																																																																												
DESIGNATO	DESIGNATO	DESIGNATO	DESIGNATO																																																																												
CONTROLATO	CONTROLATO	CONTROLATO	CONTROLATO																																																																												
DATA	DATA	DATA	DATA																																																																												
DATA	DATA	DATA	DATA																																																																												
<table border="1" style="width:100%; border-collapse: collapse;"> <thead> <tr> <th>Modello</th> <th>Resistenza</th> <th>Valore</th> <th>Descrizione</th> </tr> </thead> <tbody> <tr> <td>DATA-FIRMA</td> <td>DATA-FIRMA</td> <td>DATA-FIRMA</td> <td>DATA-FIRMA</td> </tr> <tr> <td>DISCUSSIONE MODIFICA</td> <td>DISCUSSIONE MODIFICA</td> <td>DISCUSSIONE MODIFICA</td> <td>DISCUSSIONE MODIFICA</td> </tr> <tr> <td>DESIGNATO</td> <td>DESIGNATO</td> <td>DESIGNATO</td> <td>DESIGNATO</td> </tr> <tr> <td>CONTROLATO</td> <td>CONTROLATO</td> <td>CONTROLATO</td> <td>CONTROLATO</td> </tr> <tr> <td>DATA</td> <td>DATA</td> <td>DATA</td> <td>DATA</td> </tr> <tr> <td>DATA</td> <td>DATA</td> <td>DATA</td> <td>DATA</td> </tr> </tbody> </table>																Modello	Resistenza	Valore	Descrizione	DATA-FIRMA	DATA-FIRMA	DATA-FIRMA	DATA-FIRMA	DISCUSSIONE MODIFICA	DISCUSSIONE MODIFICA	DISCUSSIONE MODIFICA	DISCUSSIONE MODIFICA	DESIGNATO	DESIGNATO	DESIGNATO	DESIGNATO	CONTROLATO	CONTROLATO	CONTROLATO	CONTROLATO	DATA	DATA	DATA	DATA	DATA	DATA	DATA	DATA																																				
Modello	Resistenza	Valore	Descrizione																																																																												
DATA-FIRMA	DATA-FIRMA	DATA-FIRMA	DATA-FIRMA																																																																												
DISCUSSIONE MODIFICA	DISCUSSIONE MODIFICA	DISCUSSIONE MODIFICA	DISCUSSIONE MODIFICA																																																																												
DESIGNATO	DESIGNATO	DESIGNATO	DESIGNATO																																																																												
CONTROLATO	CONTROLATO	CONTROLATO	CONTROLATO																																																																												
DATA	DATA	DATA	DATA																																																																												
DATA	DATA	DATA	DATA																																																																												
<table border="1" style="width:100%; border-collapse: collapse;"> <thead> <tr> <th>Modello</th> <th>Resistenza</th> <th>Valore</th> <th>Descrizione</th> </tr> </thead> <tbody> <tr> <td>DATA-FIRMA</td> <td>DATA-FIRMA</td> <td>DATA-FIRMA</td> <td>DATA-FIRMA</td> </tr> <tr> <td>DISCUSSIONE MODIFICA</td> <td>DISCUSSIONE MODIFICA</td> <td>DISCUSSIONE MODIFICA</td> <td>DISCUSSIONE MODIFICA</td> </tr> <tr> <td>DESIGNATO</td> <td>DESIGNATO</td> <td>DESIGNATO</td> <td>DESIGNATO</td> </tr> <tr> <td>CONTROLATO</td> <td>CONTROLATO</td> <td>CONTROLATO</td> <td>CONTROLATO</td> </tr> <tr> <td>DATA</td> <td>DATA</td> <td>DATA</td> <td>DATA</td> </tr> <tr> <td>DATA</td> <td>DATA</td> <td>DATA</td> <td>DATA</td> </tr> </tbody> </table>																Modello	Resistenza	Valore	Descrizione	DATA-FIRMA	DATA-FIRMA	DATA-FIRMA	DATA-FIRMA	DISCUSSIONE MODIFICA	DISCUSSIONE MODIFICA	DISCUSSIONE MODIFICA	DISCUSSIONE MODIFICA	DESIGNATO	DESIGNATO	DESIGNATO	DESIGNATO	CONTROLATO	CONTROLATO	CONTROLATO	CONTROLATO	DATA	DATA	DATA	DATA	DATA	DATA	DATA	DATA																																				
Modello	Resistenza	Valore	Descrizione																																																																												
DATA-FIRMA	DATA-FIRMA	DATA-FIRMA	DATA-FIRMA																																																																												
DISCUSSIONE MODIFICA	DISCUSSIONE MODIFICA	DISCUSSIONE MODIFICA	DISCUSSIONE MODIFICA																																																																												
DESIGNATO	DESIGNATO	DESIGNATO	DESIGNATO																																																																												
CONTROLATO	CONTROLATO	CONTROLATO	CONTROLATO																																																																												
DATA	DATA	DATA	DATA																																																																												
DATA	DATA	DATA	DATA																																																																												
<table border="1" style="width:100%; border-collapse: collapse;"> <thead> <tr> <th>Modello</th> <th>Resistenza</th> <th>Valore</th> <th>Descrizione</th> </tr> </thead> <tbody> <tr> <td>DATA-FIRMA</td> <td>DATA-FIRMA</td> <td>DATA-FIRMA</td> <td>DATA-FIRMA</td> </tr> <tr> <td>DISCUSSIONE MODIFICA</td> <td>DISCUSSIONE MODIFICA</td> <td>DISCUSSIONE MODIFICA</td> <td>DISCUSSIONE MODIFICA</td> </tr> <tr> <td>DESIGNATO</td> <td>DESIGNATO</td> <td>DESIGNATO</td> <td>DESIGNATO</td> </tr> <tr> <td>CONTROLATO</td> <td>CONTROLATO</td> <td>CONTROLATO</td> <td>CONTROLATO</td> </tr> <tr> <td>DATA</td> <td>DATA</td> <td>DATA</td> <td>DATA</td> </tr> <tr> <td>DATA</td> <td>DATA</td> <td>DATA</td> <td>DATA</td> </tr> </tbody> </table>																Modello	Resistenza	Valore	Descrizione	DATA-FIRMA	DATA-FIRMA	DATA-FIRMA	DATA-FIRMA	DISCUSSIONE MODIFICA	DISCUSSIONE MODIFICA	DISCUSSIONE MODIFICA	DISCUSSIONE MODIFICA	DESIGNATO	DESIGNATO	DESIGNATO	DESIGNATO	CONTROLATO	CONTROLATO	CONTROLATO	CONTROLATO	DATA	DATA	DATA	DATA	DATA	DATA	DATA	DATA																																				
Modello	Resistenza	Valore	Descrizione																																																																												
DATA-FIRMA	DATA-FIRMA	DATA-FIRMA	DATA-FIRMA																																																																												
DISCUSSIONE MODIFICA	DISCUSSIONE MODIFICA	DISCUSSIONE MODIFICA	DISCUSSIONE MODIFICA																																																																												
DESIGNATO	DESIGNATO	DESIGNATO	DESIGNATO																																																																												
CONTROLATO	CONTROLATO	CONTROLATO	CONTROLATO																																																																												
DATA	DATA	DATA	DATA																																																																												
DATA	DATA	DATA	DATA																																																																												
<table border="1" style="width:100%; border-collapse: collapse;"> <thead> <tr> <th>Modello</th> <th>Resistenza</th> <th>Valore</th> <th>Descrizione</th> </tr> </thead> <tbody> <tr> <td>DATA-FIRMA</td> <td>DATA-FIRMA</td> <td>DATA-FIRMA</td> <td>DATA-FIRMA</td> </tr> <tr> <td>DISCUSSIONE MODIFICA</td> <td>DISCUSSIONE MODIFICA</td> <td>DISCUSSIONE MODIFICA</td> <td>DISCUSSIONE MODIFICA</td> </tr> <tr> <td>DESIGNATO</td> <td>DESIGNATO</td> <td>DESIGNATO</td> <td>DESIGNATO</td> </tr> <tr> <td>CONTROLATO</td> <td>CONTROLATO</td> <td>CONTROLATO</td> <td>CONTROLATO</td> </tr> <tr> <td>DATA</td> <td>DATA</td> <td>DATA</td> <td>DATA</td> </tr> <tr> <td>DATA</td> <td>DATA</td> <td>DATA</td> <td>DATA</td> </tr> </tbody> </table>																Modello	Resistenza	Valore	Descrizione	DATA-FIRMA	DATA-FIRMA	DATA-FIRMA	DATA-FIRMA	DISCUSSIONE MODIFICA	DISCUSSIONE MODIFICA	DISCUSSIONE MODIFICA	DISCUSSIONE MODIFICA	DESIGNATO	DESIGNATO	DESIGNATO	DESIGNATO	CONTROLATO	CONTROLATO	CONTROLATO	CONTROLATO	DATA	DATA	DATA	DATA	DATA	DATA	DATA	DATA																																				
Modello	Resistenza	Valore	Descrizione																																																																												
DATA-FIRMA	DATA-FIRMA	DATA-FIRMA	DATA-FIRMA																																																																												
DISCUSSIONE MODIFICA	DISCUSSIONE MODIFICA	DISCUSSIONE MODIFICA	DISCUSSIONE MODIFICA																																																																												
DESIGNATO	DESIGNATO	DESIGNATO	DESIGNATO																																																																												
CONTROLATO	CONTROLATO	CONTROLATO	CONTROLATO																																																																												
DATA	DATA	DATA	DATA																																																																												
DATA	DATA	DATA	DATA																																																																												
<table border="1" style="width:100%; border-collapse: collapse;"> <thead> <tr> <th>Modello</th> <th>Resistenza</th> <th>Valore</th> <th>Descrizione</th> </tr> </thead> <tbody> <tr> <td>DATA-FIRMA</td> <td>DATA-FIRMA</td> <td>DATA-FIRMA</td> <td>DATA-FIRMA</td> </tr> <tr> <td>DISCUSSIONE MODIFICA</td> <td>DISCUSSIONE MODIFICA</td> <td>DISCUSSIONE MODIFICA</td> <td>DISCUSSIONE MODIFICA</td> </tr> <tr> <td>DESIGNATO</td> <td>DESIGNATO</td> <td>DESIGNATO</td> <td>DESIGNATO</td> </tr> <tr> <td>CONTROLATO</td> <td>CONTROLATO</td> <td>CONTROLATO</td> <td>CONTROLATO</td> </tr> <tr> <td>DATA</td> <td>DATA</td> <td>DATA</td> <td>DATA</td> </tr> <tr> <td>DATA</td> <td>DATA</td> <td>DATA</td> <td>DATA</td> </tr> </tbody> </table>																Modello	Resistenza	Valore	Descrizione	DATA-FIRMA	DATA-FIRMA	DATA-FIRMA	DATA-FIRMA	DISCUSSIONE MODIFICA	DISCUSSIONE MODIFICA	DISCUSSIONE MODIFICA	DISCUSSIONE MODIFICA	DESIGNATO	DESIGNATO	DESIGNATO	DESIGNATO	CONTROLATO	CONTROLATO	CONTROLATO	CONTROLATO	DATA	DATA	DATA	DATA	DATA	DATA	DATA	DATA																																				
Modello	Resistenza	Valore	Descrizione																																																																												
DATA-FIRMA	DATA-FIRMA	DATA-FIRMA	DATA-FIRMA																																																																												
DISCUSSIONE MODIFICA	DISCUSSIONE MODIFICA	DISCUSSIONE MODIFICA	DISCUSSIONE MODIFICA																																																																												
DESIGNATO	DESIGNATO	DESIGNATO	DESIGNATO																																																																												
CONTROLATO	CONTROLATO	CONTROLATO	CONTROLATO																																																																												
DATA	DATA	DATA	DATA																																																																												
DATA	DATA	DATA	DATA																																																																												
<table border="1" style="width:100%; border-collapse: collapse;"> <thead> <tr> <th>Modello</th> <th>Resistenza</th> <th>Valore</th> <th>Descrizione</th> </tr> </thead> <tbody> <tr> <td>DATA-FIRMA</td> <td>DATA-FIRMA</td> <td>DATA-FIRMA</td> <td>DATA-FIRMA</td> </tr> <tr> <td>DISCUSSIONE MODIFICA</td> <td>DISCUSSIONE MODIFICA</td> <td>DISCUSSIONE MODIFICA</td> <td>DISCUSSIONE MODIFICA</td> </tr> <tr> <td>DESIGNATO</td> <td>DESIGNATO</td> <td>DESIGNATO</td> <td>DESIGNATO</td> </tr> <tr> <td>CONTROLATO</td> <td>CONTROLATO</td> <td>CONTROLATO</td> <td>CONTROLATO</td> </tr> <tr> <td>DATA</td> <td>DATA</td> <td>DATA</td> <td>DATA</td> </tr> <tr> <td>DATA</td> <td>DATA</td> <td>DATA</td> <td>DATA</td> </tr> </tbody> </table>																Modello	Resistenza	Valore	Descrizione	DATA-FIRMA	DATA-FIRMA	DATA-FIRMA	DATA-FIRMA	DISCUSSIONE MODIFICA	DISCUSSIONE MODIFICA	DISCUSSIONE MODIFICA	DISCUSSIONE MODIFICA	DESIGNATO	DESIGNATO	DESIGNATO	DESIGNATO	CONTROLATO	CONTROLATO	CONTROLATO	CONTROLATO	DATA	DATA	DATA	DATA	DATA	DATA	DATA	DATA																																				
Modello	Resistenza	Valore	Descrizione																																																																												
DATA-FIRMA	DATA-FIRMA	DATA-FIRMA	DATA-FIRMA																																																																												
DISCUSSIONE MODIFICA	DISCUSSIONE MODIFICA	DISCUSSIONE MODIFICA	DISCUSSIONE MODIFICA																																																																												
DESIGNATO	DESIGNATO	DESIGNATO	DESIGNATO																																																																												
CONTROLATO	CONTROLATO	CONTROLATO	CONTROLATO																																																																												
DATA	DATA	DATA	DATA																																																																												
DATA	DATA	DATA	DATA																																																																												
<table border="1" style="width:100%; border-collapse: collapse;"> <thead> <tr> <th>Modello</th> <th>Resistenza</th> <th>Valore</th> <th>Descrizione</th> </tr> </thead> <tbody> <tr> <td>DATA-FIRMA</td> <td>DATA-FIRMA</td> <td>DATA-FIRMA</td> <td>DATA-FIRMA</td> </tr> <tr> <td>DISCUSSIONE MODIFICA</td> <td>DISCUSSIONE MODIFICA</td> <td>DISCUSSIONE MODIFICA</td> <td>DISCUSSIONE MODIFICA</td> </tr> <tr> <td>DESIGNATO</td> <td>DESIGNATO</td> <td>DESIGNATO</td> <td>DESIGNATO</td> </tr> <tr> <td>CONTROLATO</td> <td>CONTROLATO</td> <td>CONTROLATO</td> <td>CONTROLATO</td> </tr> <tr> <td>DATA</td> <td>DATA</td> <td>DATA</td> <td>DATA</td> </tr> <tr> <td>DATA</td> <td>DATA</td> <td>DATA</td> <td>DATA</td> </tr> </tbody> </table>																Modello	Resistenza	Valore	Descrizione	DATA-FIRMA	DATA-FIRMA	DATA-FIRMA	DATA-FIRMA	DISCUSSIONE MODIFICA	DISCUSSIONE MODIFICA	DISCUSSIONE MODIFICA	DISCUSSIONE MODIFICA	DESIGNATO	DESIGNATO	DESIGNATO	DESIGNATO	CONTROLATO	CONTROLATO	CONTROLATO	CONTROLATO	DATA	DATA	DATA	DATA	DATA	DATA	DATA	DATA																																				
Modello	Resistenza	Valore	Descrizione																																																																												
DATA-FIRMA	DATA-FIRMA	DATA-FIRMA	DATA-FIRMA																																																																												
DISCUSSIONE MODIFICA	DISCUSSIONE MODIFICA	DISCUSSIONE MODIFICA	DISCUSSIONE MODIFICA																																																																												
DESIGNATO	DESIGNATO	DESIGNATO	DESIGNATO																																																																												
CONTROLATO	CONTROLATO	CONTROLATO	CONTROLATO																																																																												
DATA	DATA	DATA	DATA																																																																												
DATA	DATA	DATA	DATA																																																																												
<table border="1" style="width:100%; border-collapse: collapse;"> <thead> <tr> <th>Modello</th> <th>Resistenza</th> <th>Valore</th> <th>Descrizione</th> </tr> </thead> <tbody> <tr> <td>DATA-FIRMA</td> <td>DATA-FIRMA</td> <td>DATA-FIRMA</td> <td>DATA-FIRMA</td> </tr> <tr> <td>DISCUSSIONE MODIFICA</td> <td>DISCUSSIONE MODIFICA</td> <td>DISCUSSIONE MODIFICA</td> <td>DISCUSSIONE MODIFICA</td> </tr> <tr> <td>DESIGNATO</td> <td>DESIGNATO</td> <td>DESIGNATO</td> <td>DESIGNATO</td> </tr> <tr> <td>CONTROLATO</td> <td>CONTROLATO</td> <td>CONTROLATO</td> <td>CONTROLATO</td> </tr> <tr> <td>DATA</td> <td>DATA</td> <td>DATA</td> <td>DATA</td> </tr> <tr> <td>DATA</td> <td>DATA</td> <td>DATA</td> <td>DATA</td> </tr> </tbody> </table>																Modello	Resistenza	Valore	Descrizione	DATA-FIRMA	DATA-FIRMA	DATA-FIRMA	DATA-FIRMA	DISCUSSIONE MODIFICA	DISCUSSIONE MODIFICA	DISCUSSIONE MODIFICA	DISCUSSIONE MODIFICA	DESIGNATO	DESIGNATO	DESIGNATO	DESIGNATO	CONTROLATO	CONTROLATO	CONTROLATO	CONTROLATO	DATA	DATA	DATA	DATA	DATA	DATA	DATA	DATA																																				
Modello	Resistenza	Valore	Descrizione																																																																												
DATA-FIRMA	DATA-FIRMA	DATA-FIRMA	DATA-FIRMA																																																																												
DISCUSSIONE MODIFICA	DISCUSSIONE MODIFICA	DISCUSSIONE MODIFICA	DISCUSSIONE MODIFICA																																																																												
DESIGNATO	DESIGNATO	DESIGNATO	DESIGNATO																																																																												
CONTROLATO	CONTROLATO	CONTROLATO	CONTROLATO																																																																												
DATA	DATA	DATA	DATA																																																																												
DATA	DATA	DATA	DATA																																																																												
<table border="1" style="width:100%; border-collapse: collapse;"> <thead> <tr> <th>Modello</th> <th>Resistenza</th> <th>Valore</th> <th>Descrizione</th> </tr> </thead> <tbody> <tr> <td>DATA-FIRMA</td> <td>DATA-FIRMA</td> <td>DATA-FIRMA</td> <td>DATA-FIRMA</td> </tr> <tr> <td>DISCUSSIONE MODIFICA</td> <td>DISCUSSIONE MODIFICA</td> <td>DISCUSSIONE MODIFICA</td> <td>DISCUSSIONE MODIFICA</td> </tr> <tr> <td>DESIGNATO</td> <td>DESIGNATO</td> <td>DESIGNATO</td> <td>DESIGNATO</td> </tr> <tr> <td>CONTROLATO</td> <td>CONTROLATO</td> <td>CONTROLATO</td> <td>CONTROLATO</td> </tr> <tr> <td>DATA</td> <td>DATA</td> <td>DATA</td> <td>DATA</td> </tr> <tr> <td>DATA</td> <td>DATA</td> <td>DATA</td> <td>DATA</td> </tr> </tbody> </table>																Modello	Resistenza	Valore	Descrizione	DATA-FIRMA	DATA-FIRMA	DATA-FIRMA	DATA-FIRMA	DISCUSSIONE MODIFICA	DISCUSSIONE MODIFICA	DISCUSSIONE MODIFICA	DISCUSSIONE MODIFICA	DESIGNATO	DESIGNATO	DESIGNATO	DESIGNATO	CONTROLATO	CONTROLATO	CONTROLATO	CONTROLATO	DATA	DATA	DATA	DATA	DATA	DATA	DATA	DATA																																				
Modello	Resistenza	Valore	Descrizione																																																																												
DATA-FIRMA	DATA-FIRMA	DATA-FIRMA	DATA-FIRMA																																																																												
DISCUSSIONE MODIFICA	DISCUSSIONE MODIFICA	DISCUSSIONE MODIFICA	DISCUSSIONE MODIFICA																																																																												
DESIGNATO	DESIGNATO	DESIGNATO	DESIGNATO																																																																												
CONTROLATO	CONTROLATO	CONTROLATO	CONTROLATO																																																																												
DATA	DATA	DATA	DATA																																																																												
DATA	DATA	DATA	DATA																																																																												
<table border="1" style="width:100%; border-collapse: collapse;"> <thead> <tr> <th>Modello</th> <th>Resistenza</th> <th>Valore</th> <th>Descrizione</th> </tr> </thead> <tbody> <tr> <td>DATA-FIRMA</td> <td>DATA-FIRMA</td> <td>DATA-FIRMA</td> <td>DATA-FIRMA</td> </tr> <tr> <td>DISCUSSIONE MODIFICA</td> <td>DISCUSSIONE MODIFICA</td> <td>DISCUSSIONE MODIFICA</td> <td>DISCUSSIONE MODIFICA</td> </tr> <tr> <td>DESIGNATO</td> <td>DESIGNATO</td> <td>DESIGNATO</td> <td>DESIGNATO</td> </tr> <tr> <td>CONTROLATO</td> <td>CONTROLATO</td> <td>CONTROLATO</td> <td>CONTROLATO</td> </tr> <tr> <td>DATA</td> <td>DATA</td> <td>DATA</td> <td>DATA</td> </tr> <tr> <td>DATA</td> <td>DATA</td> <td>DATA</td> <td>DATA</td> </tr> </tbody> </table>																Modello	Resistenza	Valore	Descrizione	DATA-FIRMA	DATA-FIRMA	DATA-FIRMA	DATA-FIRMA	DISCUSSIONE MODIFICA	DISCUSSIONE MODIFICA	DISCUSSIONE MODIFICA	DISCUSSIONE MODIFICA	DESIGNATO	DESIGNATO	DESIGNATO	DESIGNATO	CONTROLATO	CONTROLATO	CONTROLATO	CONTROLATO	DATA	DATA	DATA	DATA	DATA	DATA	DATA	DATA																																				
Modello	Resistenza	Valore	Descrizione																																																																												
DATA-FIRMA	DATA-FIRMA	DATA-FIRMA	DATA-FIRMA																																																																												
DISCUSSIONE MODIFICA	DISCUSSIONE MODIFICA	DISCUSSIONE MODIFICA	DISCUSSIONE MODIFICA																																																																												
DESIGNATO	DESIGNATO	DESIGNATO	DESIGNATO																																																																												
CONTROLATO	CONTROLATO	CONTROLATO	CONTROLATO																																																																												
DATA	DATA	DATA	DATA																																																																												
DATA	DATA	DATA	DATA																																																																												
<table border="1" style="width:100%; border-collapse: collapse;"> <thead> <tr> <th>Modello</th> <th>Resistenza</th> <th>Valore</th> <th>Descrizione</th> </tr> </thead> <tbody> <tr> <td>DATA-FIRMA</td> <td>DATA-FIRMA</td> <td>DATA-FIRMA</td> <td>DATA-FIRMA</td> </tr> <tr> <td>DISCUSSIONE MODIFICA</td> <td>DISCUSSIONE MODIFICA</td> <td>DISCUSSIONE MODIFICA</td> <td>DISCUSSIONE MODIFICA</td> </tr> <tr> <td>DESIGNATO</td> <td>DESIGNATO</td> <td>DESIGNATO</td> <td>DESIGNATO</td> </tr> <tr> <td>CONTROLATO</td> <td>CONTROLATO</td> <td>CONTROLATO</td> <td>CONTROLATO</td> </tr> <tr> <td>DATA</td> <td>DATA</td> <td>DATA</td> <td>DATA</td> </tr> <tr> <td>DATA</td> <td>DATA</td> <td>DATA</td> <td>DATA</td> </tr> </tbody> </table>																Modello	Resistenza	Valore	Descrizione	DATA-FIRMA	DATA-FIRMA	DATA-FIRMA	DATA-FIRMA	DISCUSSIONE MODIFICA	DISCUSSIONE MODIFICA	DISCUSSIONE MODIFICA	DISCUSSIONE MODIFICA	DESIGNATO	DESIGNATO	DESIGNATO	DESIGNATO	CONTROLATO	CONTROLATO	CONTROLATO	CONTROLATO	DATA	DATA	DATA	DATA	DATA	DATA	DATA	DATA																																				
Modello	Resistenza	Valore	Descrizione																																																																												
DATA-FIRMA	DATA-FIRMA	DATA-FIRMA	DATA-FIRMA																																																																												
DISCUSSIONE MODIFICA	DISCUSSIONE MODIFICA	DISCUSSIONE MODIFICA	DISCUSSIONE MODIFICA																																																																												
DESIGNATO	DESIGNATO	DESIGNATO	DESIGNATO																																																																												
CONTROLATO	CONTROLATO	CONTROLATO	CONTROLATO																																																																												
DATA	DATA	DATA	DATA																																																																												
DATA	DATA	DATA	DATA																																																																												
<table border="1" style="width:100%; border-collapse: collapse;"> <thead> <tr> <th>Modello</th> <th>Resistenza</th> <th>Valore</th> <th>Descrizione</th> </tr> </thead> <tbody> <tr> <td>DATA-FIRMA</td> <td>DATA-FIRMA</td> <td>DATA-FIRMA</td> <td>DATA-FIRMA</td> </tr> <tr> <td>DISCUSSIONE MODIFICA</td> <td>DISCUSSIONE MODIFICA</td> <td>DISCUSSIONE MODIFICA</td> <td>DISCUSSIONE MODIFICA</td> </tr> <tr> <td>DESIGNATO</td> <td>DESIGNATO</td> <td>DESIGNATO</td> <td>DESIGNATO</td> </tr> <tr> <td>CONTROLATO</td> <td>CONTROLATO</td> <td>CONTROLATO</td> <td>CONTROLATO</td> </tr> <tr> <td>DATA</td> <td>DATA</td> <td>DATA</td> <td>DATA</td> </tr> <tr> <td>DATA</td> <td>DATA</td> <td>DATA</td> <td>DATA</td> </tr> </tbody> </table>																Modello	Resistenza	Valore	Descrizione	DATA-FIRMA	DATA-FIRMA	DATA-FIRMA	DATA-FIRMA	DISCUSSIONE MODIFICA	DISCUSSIONE MODIFICA	DISCUSSIONE MODIFICA	DISCUSSIONE MODIFICA	DESIGNATO	DESIGNATO	DESIGNATO	DESIGNATO	CONTROLATO	CONTROLATO	CONTROLATO	CONTROLATO	DATA	DATA	DATA	DATA	DATA	DATA	DATA	DATA																																				
Modello	Resistenza	Valore	Descrizione																																																																												
DATA-FIRMA	DATA-FIRMA	DATA-FIRMA	DATA-FIRMA																																																																												
DISCUSSIONE MODIFICA	DISCUSSIONE MODIFICA	DISCUSSIONE MODIFICA	DISCUSSIONE MODIFICA																																																																												
DESIGNATO	DESIGNATO	DESIGNATO	DESIGNATO																																																																												
CONTROLATO	CONTROLATO	CONTROLATO	CONTROLATO																																																																												
DATA	DATA	DATA	DATA																																																																												
DATA	DATA	DATA	DATA																																																																												
<table border="1" style="width:100%; border-collapse: collapse;"> <thead> <tr> <th>Modello</th> <th>Resistenza</th> <th>Valore</th> <th>Descrizione</th> </tr> </thead> <tbody> <tr> <td>DATA-FIRMA</td> <td>DATA-FIRMA</td> <td>DATA-FIRMA</td> <td>DATA-FIRMA</td> </tr> <tr> <td>DISCUSSIONE MODIFICA</td> <td>DISCUSSIONE MODIFICA</td> <td>DISCUSSIONE MODIFICA</td> <td>DISCUSSIONE MODIFICA</td> </tr> <tr> <td>DESIGNATO</td> <td>DESIGNATO</td> <td>DESIGNATO</td> <td>DESIGNATO</td> </tr> <tr> <td>CONTROLATO</td> <td>CONTROLATO</td> <td>CONTROLATO</td> <td>CONTROLATO</td> </tr> <tr> <td>DATA</td> <td>DATA</td> <td>DATA</td> <td>DATA</td> </tr> <tr> <td>DATA</td> <td>DATA</td> <td>DATA</td> <td>DATA</td> </tr> </tbody> </table>																Modello	Resistenza	Valore	Descrizione	DATA-FIRMA	DATA-FIRMA	DATA-FIRMA	DATA-FIRMA	DISCUSSIONE MODIFICA	DISCUSSIONE MODIFICA	DISCUSSIONE MODIFICA	DISCUSSIONE MODIFICA	DESIGNATO	DESIGNATO	DESIGNATO	DESIGNATO	CONTROLATO	CONTROLATO	CONTROLATO	CONTROLATO	DATA	DATA	DATA	DATA	DATA	DATA	DATA	DATA																																				
Modello	Resistenza	Valore	Descrizione																																																																												
DATA-FIRMA	DATA-FIRMA	DATA-FIRMA	DATA-FIRMA																																																																												
DISCUSSIONE MODIFICA	DISCUSSIONE MODIFICA	DISCUSSIONE MODIFICA	DISCUSSIONE MODIFICA																																																																												
DESIGNATO	DESIGNATO	DESIGNATO	DESIGNATO																																																																												
CONTROLATO	CONTROLATO	CONTROLATO	CONTROLATO																																																																												
DATA	DATA	DATA	DATA																																																																												
DATA	DATA	DATA	DATA																																																																												
<table border="1" style="width:100%; border-collapse: collapse;"> <thead> <tr> <th>Modello</th> <th>Resistenza</th> <th>Valore</th> <th>Descrizione</th> </tr> </thead> <tbody> <tr> <td>DATA-FIRMA</td> <td>DATA-FIRMA</td> <td>DATA-FIRMA</td> <td>DATA-FIRMA</td> </tr> <tr> <td>DISCUSSIONE MODIFICA</td> <td>DISCUSSIONE MODIFICA</td> <td>DISCUSSIONE MODIFICA</td> <td>DISCUSSIONE MODIFICA</td> </tr> <tr> <td>DESIGNATO</td> <td>DESIGNATO</td> <td>DESIGNATO</td> <td>DESIGNATO</td> </tr> <tr> <td>CONTROLATO</td> <td>CONTROLATO</td> <td>CONTROLATO</td> <td>CONTROLATO</td> </tr> <tr> <td>DATA</td> <td>DATA</td> <td>DATA</td> <td>DATA</td> </tr> <tr> <td>DATA</td> <td>DATA</td> <td>DATA</td> <td>DATA</td> </tr> </tbody> </table>																Modello	Resistenza	Valore	Descrizione	DATA-FIRMA	DATA-FIRMA	DATA-FIRMA	DATA-FIRMA	DISCUSSIONE MODIFICA	DISCUSSIONE MODIFICA	DISCUSSIONE MODIFICA	DISCUSSIONE MODIFICA	DESIGNATO	DESIGNATO	DESIGNATO	DESIGNATO	CONTROLATO	CONTROLATO	CONTROLATO	CONTROLATO	DATA	DATA	DATA	DATA	DATA	DATA	DATA	DATA																																				
Modello	Resistenza	Valore	Descrizione																																																																												
DATA-FIRMA	DATA-FIRMA	DATA-FIRMA	DATA-FIRMA																																																																												
DISCUSSIONE MODIFICA	DISCUSSIONE MODIFICA	DISCUSSIONE MODIFICA	DISCUSSIONE MODIFICA																																																																												
DESIGNATO	DESIGNATO	DESIGNATO	DESIGNATO																																																																												
CONTROLATO	CONTROLATO	CONTROLATO	CONTROLATO																																																																												
DATA	DATA	DATA	DATA																																																																												
DATA	DATA	DATA	DATA																																																																												
<table border="1" style="width:100%; border-collapse: collapse;"> <thead> <tr> <th>Modello</th> <th>Resistenza</th> <th>Valore</th> <th>Descrizione</th></tr></thead></table>																Modello	Resistenza	Valore	Descrizione																																																												
Modello	Resistenza	Valore	Descrizione																																																																												

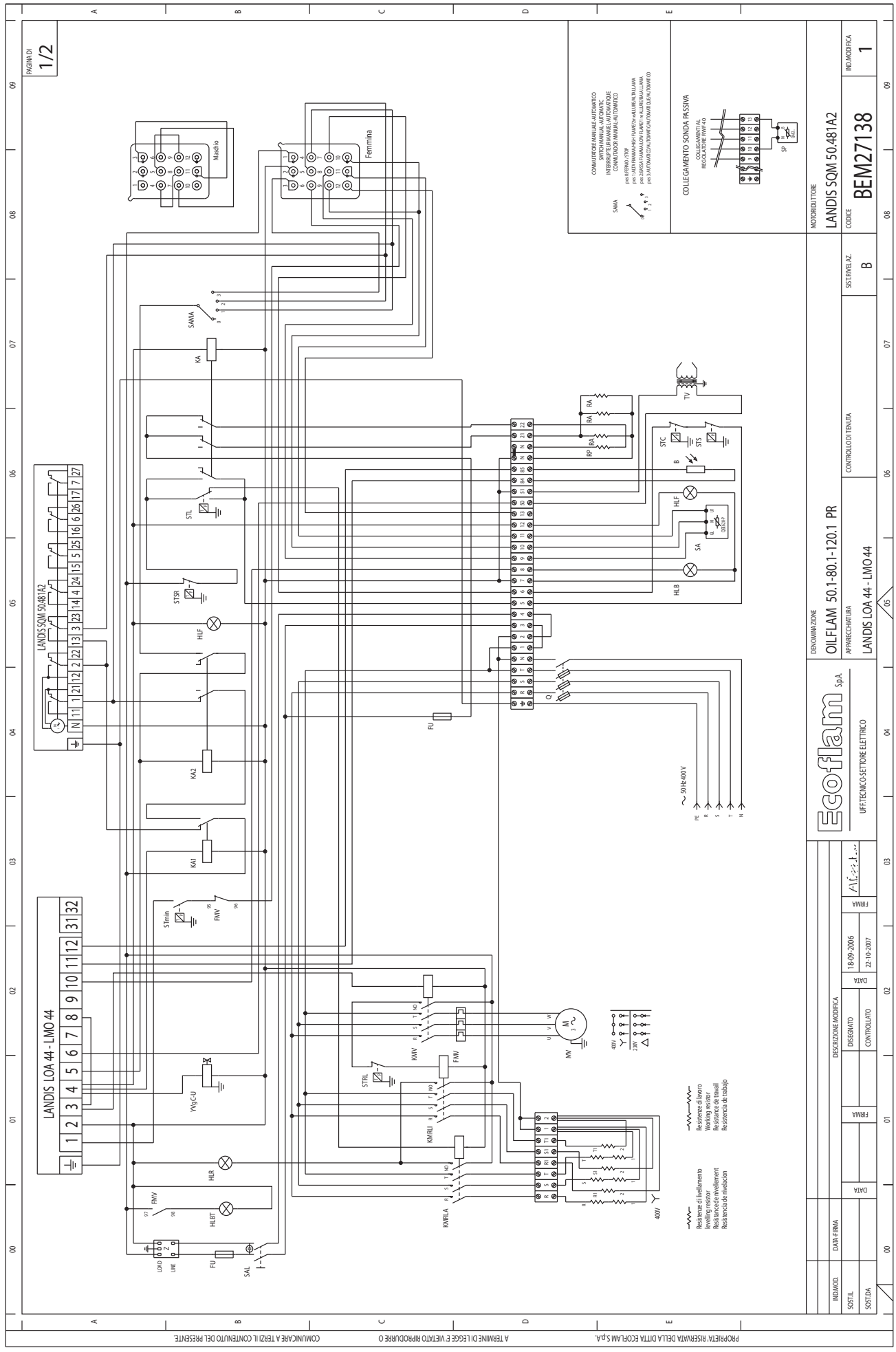

INDICAZIONE	OILFLAM 50.1-80.1-120.1 PR		CONTROLLO/TENUTA	B																																											
SOSTITUIRE	APPARECCHIATURA		LANDIS LOA 44 - LMO 44																																												
SOSTITUIRE	Ecoflam S.p.A.																																														
UFF. TECNICO-SETTORE ELETTRICO																																															
INDICAZIONE	DESCRIZIONE MODIFICA		FRIMA	DATA	FRIMA																																										
SOSTITUIRE	DESEGNATO	CONTROLLO	FRIMA	DATA	FRIMA																																										
SOSTITUIRE	DESEGNATO	CONTROLLO	FRIMA	DATA	FRIMA																																										
<table border="1"> <tr> <td>INDICAZIONE</td> <td colspan="2">OILFLAM 50.1-80.1-120.1 PR</td> <td>CONTROLLO/TENUTA</td> <td colspan="2">B</td> </tr> <tr> <td>SOSTITUIRE</td> <td colspan="2">APPARECCHIATURA</td> <td colspan="3">LANDIS LOA 44 - LMO 44</td> </tr> <tr> <td>SOSTITUIRE</td> <td colspan="5">Ecoflam S.p.A.</td> </tr> <tr> <td colspan="6">UFF. TECNICO-SETTORE ELETTRICO</td> </tr> <tr> <td>INDICAZIONE</td> <td colspan="2">DESCRIZIONE MODIFICA</td> <td>FRIMA</td> <td>DATA</td> <td>FRIMA</td> </tr> <tr> <td>SOSTITUIRE</td> <td>DESEGNATO</td> <td>CONTROLLO</td> <td>FRIMA</td> <td>DATA</td> <td>FRIMA</td> </tr> <tr> <td>SOSTITUIRE</td> <td>DESEGNATO</td> <td>CONTROLLO</td> <td>FRIMA</td> <td>DATA</td> <td>FRIMA</td> </tr> </table>						INDICAZIONE	OILFLAM 50.1-80.1-120.1 PR		CONTROLLO/TENUTA	B		SOSTITUIRE	APPARECCHIATURA		LANDIS LOA 44 - LMO 44			SOSTITUIRE	Ecoflam S.p.A.					UFF. TECNICO-SETTORE ELETTRICO						INDICAZIONE	DESCRIZIONE MODIFICA		FRIMA	DATA	FRIMA	SOSTITUIRE	DESEGNATO	CONTROLLO	FRIMA	DATA	FRIMA	SOSTITUIRE	DESEGNATO	CONTROLLO	FRIMA	DATA	FRIMA
INDICAZIONE	OILFLAM 50.1-80.1-120.1 PR		CONTROLLO/TENUTA	B																																											
SOSTITUIRE	APPARECCHIATURA		LANDIS LOA 44 - LMO 44																																												
SOSTITUIRE	Ecoflam S.p.A.																																														
UFF. TECNICO-SETTORE ELETTRICO																																															
INDICAZIONE	DESCRIZIONE MODIFICA		FRIMA	DATA	FRIMA																																										
SOSTITUIRE	DESEGNATO	CONTROLLO	FRIMA	DATA	FRIMA																																										
SOSTITUIRE	DESEGNATO	CONTROLLO	FRIMA	DATA	FRIMA																																										
<table border="1"> <tr> <td>MOTORE/LETTORE</td> <td colspan="2">LANDIS SQM 50.481A2</td> <td colspan="3">IND. MODIFICA</td> </tr> <tr> <td>INDICAZIONE</td> <td colspan="2">LANDIS SQM 50.481A2</td> <td colspan="3">1</td> </tr> <tr> <td>SOSTITUIRE</td> <td colspan="2">CODICE</td> <td colspan="3">BEM27138</td> </tr> </table>						MOTORE/LETTORE	LANDIS SQM 50.481A2		IND. MODIFICA			INDICAZIONE	LANDIS SQM 50.481A2		1			SOSTITUIRE	CODICE		BEM27138																										
MOTORE/LETTORE	LANDIS SQM 50.481A2		IND. MODIFICA																																												
INDICAZIONE	LANDIS SQM 50.481A2		1																																												
SOSTITUIRE	CODICE		BEM27138																																												

PAGINA D 2/2	09	08	07	06	05	04	03	02	01	00																								
<p>RESISTENZE BRILLOTTO OILET AM RESISTANCE RECHAUFFEUR OILFLAM RESISTENCIA RECALORADOR OILFLAM</p> <table border="1" style="margin-left: auto; margin-right: auto;"> <tr> <td>Modelo</td> <td>Leveling</td> <td>Leveling</td> <td>Leveling</td> </tr> <tr> <td>Modelo</td> <td>Novelment</td> <td>Novelment</td> <td>Novelment</td> </tr> <tr> <td>Modelo</td> <td>Total</td> <td>Total</td> <td>Total</td> </tr> <tr> <td>50</td> <td>3000 W</td> <td>1350 W</td> <td>1650 W</td> </tr> <tr> <td>80</td> <td>4650 W</td> <td>2250 W</td> <td>2400 W</td> </tr> <tr> <td>120</td> <td>7050 W</td> <td>3000 W</td> <td>4050 W</td> </tr> </table>											Modelo	Leveling	Leveling	Leveling	Modelo	Novelment	Novelment	Novelment	Modelo	Total	Total	Total	50	3000 W	1350 W	1650 W	80	4650 W	2250 W	2400 W	120	7050 W	3000 W	4050 W
Modelo	Leveling	Leveling	Leveling																															
Modelo	Novelment	Novelment	Novelment																															
Modelo	Total	Total	Total																															
50	3000 W	1350 W	1650 W																															
80	4650 W	2250 W	2400 W																															
120	7050 W	3000 W	4050 W																															
<p>A</p> <p style="text-align: center;">LANDIS SQM 50.381A2</p> <p style="text-align: center;">230V</p>	<p>B</p> <p>(07) I: CAMMIA DI REGOLAZIONE ARIA DI MASSIMA (15) II: CAMMIA DI REGOLAZIONE ARIA DI ACCENSIONE (30) III: CAMMIA DI REGOLAZIONE ARIA DI BASSA (07) IV: CAMMIA NON UTILIZZATA (07) V: CAMMIA NON UTILIZZATA</p>	<p>C</p> <p style="text-align: center;">230V</p>	<p>D</p> <p>ATTENZIONE: LE RESISTENZE AUSILIARIE "RA" SONO DI SERIE SOLO PER BRUCIATORI OILFLAM 50-80-120 AB/D</p> <p>WARNING: THE AUXILIARY RESISTORS "RA" ARE CURRENTLY SUPPLIED WITH OILFLAM 50-80-120 AB/D BURNERS ONLY</p> <p>ATTENTION: LES RESISTANCES AUXILIAIRES "RA" SONT DE SERIE SEULEMENT SUR LES BRULLEURS OILFLAM 50-80-120 AB/D</p> <p>CAUTION: LAS RESISTENCIAS AUXILIARIAS "RA" SON DE SERIE SOLO PARA LOS QUEMADORES OILFLAM 50-80-120 AB/D</p>	<p>E</p>																														
<p>COMUNICARE A TERZI IL CONTENUTO DEL PRESENTE A TERMINER D'LEGEE V'ETROU RIPRODURE O PROPRIETA: RISERVATA DELLA DITTA ECOFLAM S.p.A</p>																																		
<p>B</p> <p>FOTORESISTENZA PHOTO-RESISTOR FOTORESISTENCIA</p>		<p>SAL</p> <p>INTERRUTTORE DI LINEA WORKINGS SWITCH INTERRUPTEUR DE LIGNE INTERRUPTOR DE LINEA</p>		<p>STC</p> <p>TERMOSTATO CALDRIA BOILER THERMOSTAT THERMOSTAT CALDERA</p>		<p>STL</p> <p>TERMOSTATO DI LAVORO WORKING THERMOSTAT THERMOSTAT TRAVAIL</p>		<p>STS</p> <p>TERMOSTATO DI SICUREZZA SAFETY THERMOSTAT THERMOSTAT DE SECURITE TERMOSTATO DE SEGURIDAD</p>		<p>STR</p> <p>TERMOSTATO RESISTENZE DI LIVELLAMENTO LEVELING RESISTANCES THERMOSTAT THERMOSTAT DES RESISTENCIAS DE NIVELAMIENTO</p>		<p>STR</p> <p>TERMOSTATO DI SICUREZZA RESISTENZE RESISTOR SAFETY THERMOSTAT THERMOSTAT DE SECURITE RESISTANCES TERMOSTATO DE SEGURIDAD RESISTENCIAS</p>		<p>RMRLA</p> <p>CONIATTORE RESISTENZE DI LAVORO WORKING RESISTOR SWITCH INTERRUPTEUR DES RESISTANCES DE TRAVAIL INTERRUPTOR DE LAS RESISTENCIAS DE TRABAJO</p>		<p>RMRL</p> <p>CONIATTORE RESISTENZE DI LIVELLAMENTO LEVELING RESISTOR SWITCH INTERRUPTEUR DES RESISTANCES DE NIVELAMIENTO INTERRUPTOR DE LAS RESISTENCIAS DE NIVELACION</p>		<p>5tmin</p> <p>TERMOSTATO DI MINIMA THERMOSTAT MIN THERMOSTAT DE MIN TERMOSTATO DE MINIMA</p>		<p>WgC-U</p> <p>SOLENOIDE CHIUSURA VELOGLIO</p>		<p>SA</p> <p>SONDA ATTIVA ACTIVE SONDE SONDE ACTIVE SONDA ACTIVA</p>		<p>SP</p> <p>SONDA PASSIVA USING PASSIVE SONDE PASSIVE SONDA PASIVA</p>		<p>HLBT</p> <p>LAMPADA DI BLOCCO TERMICO THERMAL LOCK-OUT LAMP LAMPE DE THERMAL DE SECURITE ESPIA DE BLOQUEO RELE TERMICO</p>								
<p>Q</p> <p>INTERUTTORE GENERALE CONFUSIBILE MIXED SWITCH WITH POSSIBLE CONFUSION INTERRUPTOR GENERAL CONFUSIBLE</p>		<p>Z</p> <p>FILTRO ANTIDISTURBO ANTI-JAMMING FILTER FILTRE ANTIPARASITES FILTRO DE PROTECCION ANTIDISTURBO</p>		<p>FU</p> <p>FUSIBILE FUSE FUSIBLE FUSIBLE</p>		<p>K41</p> <p>RELE RELAY RELAIS RELE</p>		<p>K42</p> <p>RELE RELAY RELAIS RELE</p>		<p>MV</p> <p>MOTORE VENTILATORE MOTOR FAN MOTEUR VENTILATEUR MOTOR VENTILADOR</p>		<p>RA</p> <p>RESISTENZA AUSILIARIA AUXILIARY RESISTANCE RESISTENCIA AUXILIARIA</p>		<p>RP</p> <p>RESISTENZA POMPA PUMP RESISTOR RESISTANCE POMPE RESISTENCIA BOMBA</p>		<p>TV</p> <p>TRASFORMATORE IGNITION TRANSFORMER TRANSFORMATEUR D'ALLUMAGE TRANSFORMADOR</p>		<p>RMV</p> <p>RELE TERMICO MOTORE VENTILATORE THERMAL LOCK-OUT MOTOR FAN MOTOR RELE TERMICO MOTEUR VENTILATEUR RELE TERMICO MOTOR VENTILADOR</p>		<p>HLB</p> <p>LAMPADA DI BLOCCO LOCK-OUT LAMP LAMPE DE SECURITE ESPIA DE BLOQUEO</p>		<p>HLF</p> <p>LAMPADA DI FUNZIONAMENTO WORKING LAMP LAMPE DE FONCTIONNEMENT ESPIA DE FUNCIONAMIENTO</p>		<p>HLR</p> <p>LAMPADA RESISTENZE RESISTOR LAMP THERMONRESISTENCES INDICADOR RESISTENCIAS</p>		<p>MIV</p> <p>CONIATTORE MOTORE VENTILATORE REMOTE CONTROL SWITCH FAN MOTOR CONTACTEUR MOTEUR VENTILATEUR TELEERRUPTOR MOTOR VENTILADOR</p>								
<p>IND.MOD.</p> <p>SOB.TIT.</p> <p>SOB.TDA</p>		<p>DATA-FIRMA</p> <p>DESIGNATO</p> <p>CONTROLLATO</p>		<p>18-09-2006</p> <p>DATA</p>		<p>AL-32 L-2</p> <p>FIRMA</p>		<p>DISCRIZIONE MODIFICA</p>		<p>ECOFLAM S.p.A</p> <p>UFFICIO-SETTORE ELETTRICO</p>		<p>DENOMINAZIONE</p> <p>OILFLAM 50.1-80.1-120.1 PR</p> <p>APPARECCHIERA</p> <p>LANDIS LOA 44</p>		<p>MOTORIDUTTORE</p> <p>LANDIS SQM 50.481A2</p> <p>CODICE</p> <p>BEM27138</p>		<p>SIST. INVELEZ.</p> <p>B</p>		<p>IND.MODIFICA</p>																

OILFLAM 50.1-120.1 PR/MD

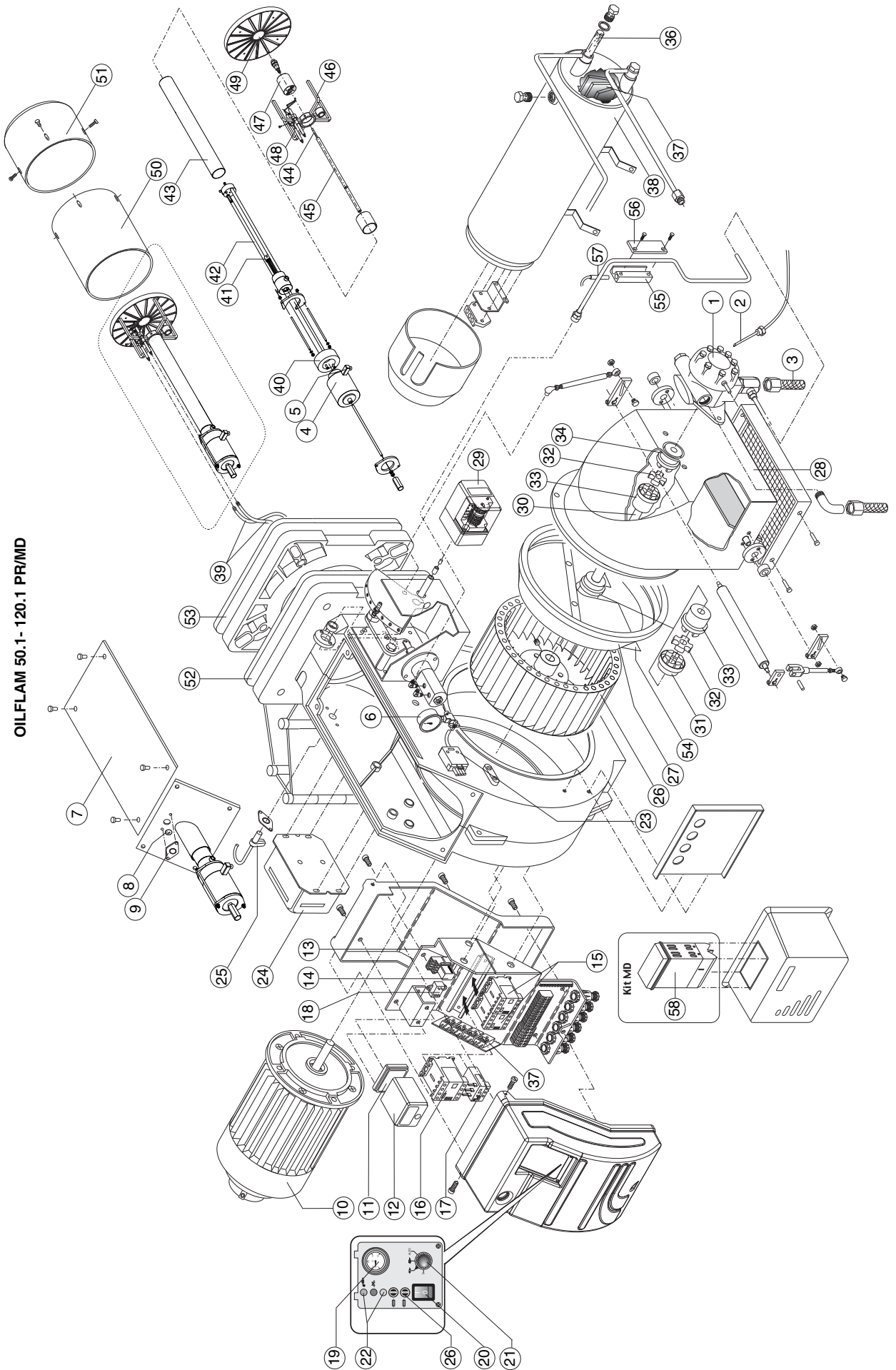

OILFLAM 170.1 - 200.1 PR/MD
OILFLAM D 170.1-200.1 PR/MD

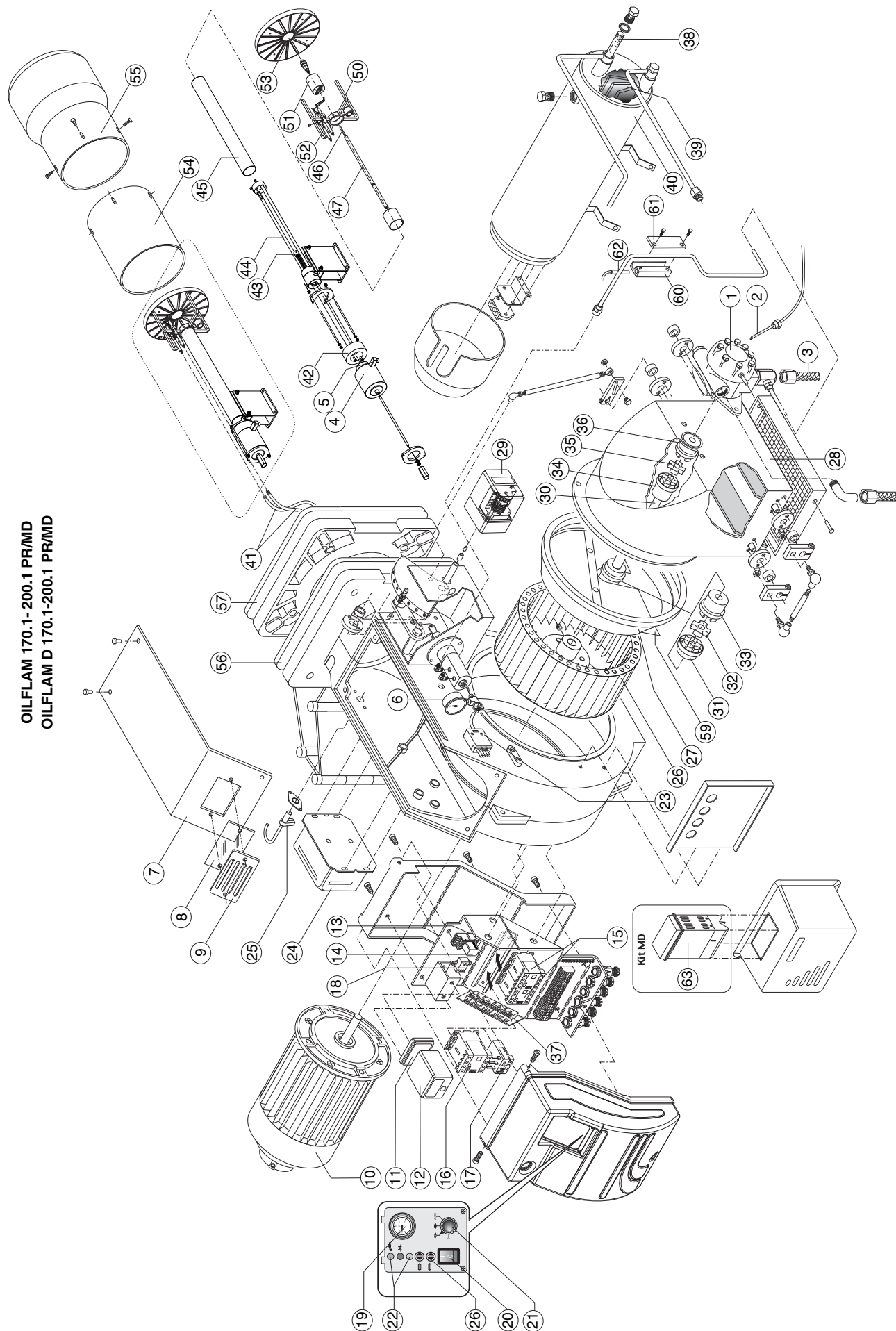

N°	DESCRIZIONE	OILFLAM 50.1 PR codice	OILFLAM 80.1 PR codice
1	- POMPA SUNTEC E4NC	P106	P106
2	- RESISTENZA POMPA 50 W	R110	R110
3	- FLESSIBILI 1" A	S901	S901
4	- BOBINA EL011	V523	V523
5	- CONETTORE BOBINA EL011	V1119/07	V1119/07
6	- MANOMETRO	S601/1	S601/1
7	- COPERCHIO		
8	- VETRINO		
9	- SUPPORTO VETRINO		
10	- MOTORE 1500 W	M174/2	M174/2
11	- ZOCCOLO LANDIS	A402	A402
12	- APPARECCHIATURA DI CONTROLLO LMO44.255A2	A112/2	A112/2
13	- ZOCCOLO RELE' FINDER (9474) R5534	R906	R906
14	- RELE' FINDER 5534	R712	R712
15	- CONTATTORE RESISTENZE AEG LS05.10	R621	R621
	AEG LS4K.10	R621/1	R621/1
16	- CONTATTORE MOTORE AEG LS05.10	R621	R621
17	- RELE' TERMICO MOTORE AEG 4-6,3 A	R521/4	R521/4
18	- FILTRO ANTIDISTURBO S132/4	S132/4	S132/4
19	- TERMOMETRO IMIT sc.0-200	R301/2	R301/2
20	- INTERRUETTORE BIPOLARE CON LED VERDE cod.4010011509	R1020	R1020
21	- SELETTORE R1020/5	R1020/5	R1020/5
22	- LAMPADA EL/N-SC4 Elettrospring	E1510	E1510
23	- SPINA WIELAND	E222	E222
24	- TRASFORMATORE BRAHMA T8	T101	T101
25	- FOTORESISTENZA LANDIS	A207/1	A207/1
26	- VENTOLA 250 x 84	BFV10157/001	-
	260 x 98	-	BFV10156/001
27	- CONVOGLIATORE	BFC08201/017	BFC08201/017
28	- CASSETTO	BFC04152/011	BFC04152/011
29	- MOTORIDUTTORE SQM50.381A2	M212/91	M212/91
30	- PERNO	BFT05104/201	BFT05104/201
31	- GIUNTO VENTOLA	BFV10201/4	BFV10201/4
32	- GIUNTO GOMMA	BFV10201/6	BFV10201/6
33	- GIUNTO INTERMEDIO	BFV10201/1	BFV10201/1
34	- GIUNTO POMPA	BFV10201/2	BFV10201/2
35	- TERMOSTATO IMIT TR2 40/200	R801/2	R801/2
36	- FILTRO	BFP01112	BFP01112
37	- RESISTENZE 3000 W	R119	-
	4650 W	-	R120
38	- BARILOTTO	BFP01010/017	BFP01011/017
39	- CAVO TC	BFE01403/1	BFE01403/1
	TL	BFE01403/3	BFE01403/3
40	- ANELLO PORTA BOBINA	BFT15224/001	BFT15224/001
41	- PORTA MOLLA	BFT15222/001	BFT15222/001
42	- TESTA DI COMBUSTIONE		
43	- TUBO		
44	- ASTA SPILLO	BLT01008	
45	- SUPPORTO ASTA SPILLO	BLT01009/001	
46	- CROCIERA		
47	- PORTA UGELLO	BFC11019	BFC11019
48	- ELETTRODI	E612	E612
49	- DIFFUSORE	BFD05010/051	BFD05010/051
50	- BOCCAGLIO TC	BFB05005/121	BFB05005/121
	TL	BFB05005/221	BFB05005/221
51	- CAMPANA INOX	BFB21009	BFB21009
52	- GUARNIZIONE	BFG03001/3	BFG03001/3
53	- GUARNIZIONE	BFG03002/3	BFG03002/3
54	- SURPRESSORE	BFC08053/001	BFC08053/001
OILFLAM D			
55	- BLOCCHETTO PRERISCALDATORE	BFT15212/1	BFT15215/1
56	- PIASTRINA	BFT15212/2	BFT15215/2
57	- RESISTENZA 50 W	R110	R110
VERSION MD			
58	- KIT CENTRALINA MODULANTE RWF 40.000A97	E2490/5514	E2490/5514

TC = TESTA CORTA

TL = TESTA LUNGA

N°	DESCRIPTION	OILFLAM 50.1 PR code	OILFLAM 80.1 PR code
1	- PUMP	SUNTEC E4NC	P106
2	- HEATING ELEMENT PUMP	50 W	R110
3	- HOSES	1" A	S901
4	- COIL	EL011	V523
5	- CONETTORE BOBINA	EL011	V1119/07
6	- MANOMETER		S601/1
7	- COVER		
8	- GLASS		
9	- PEEP WINDOW FRAME		
10	- MOTOR	1500 W	M174/2
11	- CONTROL BOX BASE	LANDIS	A402
12	- CONTROL BOX	LMO44.255A2	A112/2
13	- RELAY BASE'	FINDER (9474) R5534	R906
14	- RELAY	FINDER 5534	R712
15	- REMOTE CONTROL SWITCH	AEG LS05.10	R621
		AEG LS4K.10	R621/1
16	- REMOTE CONTROL SWITCH MOTOR	AEG LS05.10	R621
17	- MOTOR THERMAL RELAY	AEG 4-6,3 A	R521/4
18	- ANTIJAMMING FILTER		S132/4
19	- THERMOMETER	IMIT sc.0-200	R301/2
20	- MAIN SWITCH	cod.40100I1509	R1020
21	- SELECTOR		R1020/5
22	- LAMP	EL/N-SC4 Elettrospring	E1510
23	- PLUG WIELAND		E222
24	- IGNITION TRANSFORMER	BRAHMA T8	T101
25	- PHOTORESISTOR	LANDIS	A207/1
26	- FAN	250 x 84	BFV10157/001
		260 x 98	-
27	- AIR CONVEYOR		BFC08201/017
28	- COVER AIR INLET		BFC04152/011
29	- AIR DAMPER MOTOR	SQM50.381A2	M212/91
30	- ROD		BFT05104/201
31	- COUPLING (FAN)		BFV10201/4
32	- UNION		BFV10201/6
33	- COUPLING		BFV10201/1
34	- COUPLING (PUMP)		BFV10201/2
35	- THERMOSTAT	IMIT TR2 40/200	R801/2
36	- FILTER		BFP01112
37	- HEATER	3000 W	R119
		4650 W	-
38	- OIL TANK		BFP01010/017
39	- CABLE	TC	BFE01403/1
		TL	BFE01403/3
40	- RING		BFT15224/001
41	- HOLDER SPRING		BFT15222/001
42	- FIRING HEAD		
43	- PIPE		
44	- ROD NOZZLE		BLT01008
45	- ROD NOZZLE HOLDER		BLT01009/001
46	- SUPPORT NOZZLE HOLDER		
47	- NOZZLE HOLDER		BFC11019
48	- ELECTRODES		E612
49	- DIFFUSER		BFD05010/051
50	- BLAST TUBE	TC	BFB05005/121
		TL	BFB05005/221
51	- BLAST TUBE END		BFB21009
52	- GASKET		BFG03001/3
53	- GASKET		BFG03002/3
54	- FAN SCOOP		BFC08053/001
OILFLAM D			
55	- PREHEATED'S AUX. RESISTOR HOLDER		BFT15212/1
56	- FIXING PLATE		BFT15212/2
57	- HEATING ELEMENT	50 W	R110
VERSION MD			
58	- KIT MODULATING UNIT	RWF 40.000A97	E2490/5514

TC = SHORT HEAD TL = LONG HEAD

N°	DESIGNATION	OILFLAM 50.1 PR code	OILFLAM 80.1 PR code
1	- POMPE SUNTEC E4NC	P106	P106
2	- RESISTANCES 50 W	R110	R110
3	- FLEXIBLES 1" A	S901	S901
4	- BOBINE EL011	V523	V523
5	- CONETTORE BOBINA EL011	V1119/07	V1119/07
6	- MANOMETRE	S601/1	S601/1
7	- COUVERCHE DE BRULEUR		
8	- HUBLLOT		
9	- PROTECTION HUBLLOT		
10	- MOTEUR 1500 W	M174/2	M174/2
11	- SOCLE DE COFFRET LANDIS	A402	A402
12	- COFFRET DE SECURITE LMO44.255A2	A112/2	A112/2
13	- SOCLE DE RELAIS FINDER (9474) R5534	R906	R906
14	- RELAIS FINDER 5534	R712	R712
15	- TELERUPTEUR DE RESISTANCES AEG LS05.10	R621	R621
	AEG LS4K.10	R621/1	R621/1
16	- TELERUPTEUR DE MOTEUR AEG LS05.10	R621	R621
17	- RELAIS THERMIQUE AEG 4-6,3 A	R521/4	R521/4
18	- FILTRE ANTIPARASITE	S132/4	S132/4
19	- THERMOMETRE IMIT sc.0-200	R301/2	R301/2
20	- INTERRUPTEUR DE LIGNE cod.40100I1509	R1020	R1020
21	- SELECTOR	R1020/5	R1020/5
22	- LAMPE EL/N-SC4 Elettrospring	E1510	E1510
23	- FICHE MALE WIELAND	E222	E222
24	- TRANSFORMATEUR BRAHMA T8	T101	T101
25	- CELLULE LANDIS	A207/1	A207/1
26	- TURBINE 250 x 84	BFV10157/001	-
	260 x 98	-	BFV10156/001
27	- CONVOYEUR D'AIR	BFC08201/017	BFC08201/017
28	- BOITE D'AIR	BFC04152/011	BFC04152/011
29	- SERVOMOTEUR SQM50.381A2	M212/91	M212/91
30	- ARBRE DE TRASMISSION	BFT05104/201	BFT05104/201
31	- JOINT DU VENTILATEUR	BFV10201/4	BFV10201/4
32	- JOINT DE CAOUTCHOUC	BFV10201/6	BFV10201/6
33	- JOINT INTERMEDIAIRE	BFV10201/1	BFV10201/1
34	- JOINT DE LA POMPE	BFV10201/2	BFV10201/2
35	- THERMOSTAT IMIT TR2 40/200	R801/2	R801/2
36	- FILTRE	BFP01112	BFP01112
37	- RESISTANCES 3000 W	R119	-
	4650 W	-	R120
38	- RECHAUFFAGE	BFP01010/017	BFP01011/017
39	- CABLE TC	BFE01403/1	BFE01403/1
	TL	BFE01403/3	BFE01403/3
40	- ANELLO PORTA BOBINA	BFT15224/001	BFT15224/001
41	- PORTA MOLLA	BFT15222/001	BFT15222/001
42	- TETE DE COMBUSTION		
43	- TUYAU		
44	- TIGE PORTE GICLEUR	BLT01008	
45	- SUPPORTO ASTA SPILLO	BLT01009/001	
46	- SUPPORT PORTE GICLEUR		
47	- PORTE GICLEUR	BFC11019	BFC11019
48	- ELECTRODE D'ALLUMAGE	E612	E612
49	- DEFLECTEUR	BFD05010/051	BFD05010/051
50	- GUEULARD TC	BFB05005/121	BFB05005/121
	TL	BFB05005/221	BFB05005/221
51	- TERMINAL INOX	BFB21009	BFB21009
52	- JOINT	BFG03001/3	BFG03001/3
53	- JOINT	BFG03002/3	BFG03002/3
54	- SURPRESSEUR	BFC08053/001	BFC08053/001
OILFLAM D			
55	- RECHAFFEUR	BFT15212/1	BFT15215/1
56	- PLAQUETTE	BFT15212/2	BFT15215/2
57	- RESISTANCES 50 W	R110	R110
VERSION MD			
58	- KIT CENTRALINA MODULANTE RWF 40.000A97	E2490/5514	E2490/5514

TC = TETE COURTE TL = TETE LONGUE

Nº	DESCRIPCIÓN	OILFLAM 50.1 PR código	OILFLAM 80.1 PR código
1	- BOMBA	SUNTEC E4NC	P106
2	- RESISTENCIA BOMBA	50 W	R110
3	- LATIGUILLOS	1" A	S901
4	- BOBINA	EL011	V523
5	- CONETTORE BOBINA	EL011	V1119/07
6	- MANOMETRO		S601/1
7	- TAPA		
8	- VIDRIOSO		
9	- SOPORTE VIDRIOSO		
10	- MOTOR	1500 W	M174/2
11	- BASE DEL EQUIPO	LANDIS	A402
12	- EQUIPO CONTROL LLAMA	LMO44.255A2	A112/2
13	- BASE DEL RELE'	FINDER (9474) R5534	R906
14	- RELE'	FINDER 5534	R712
15	- CONTACTOR RESISTENCIAS	AEG LS05.10	R621
		AEG LS4K.10	R621/1
16	- CONTATTORE MOTORE	AEG LS05.10	R621
17	- EMPALME MOTOR VENTILADOR	AEG 4-6,3 A	R521/4
18	- FILTRO ANTITRATORNO		S132/4
19	- TERMOMETRO	IMIT sc.0-200	R301/2
20	- INTERRUPTOR DE LINEA	cod.40100I1509	R1020
21	- CONMUTADOR		R1020/5
22	- ESPIA	EL/N-SC4 Elettrospring	E1510
23	- TOMA WIELAND		E222
24	- TRANSFORMADOR	BRAHMA T8	T101
25	- FOTORRESISTENCIA	LANDIS	A207/1
26	- VENTILADOR	250 x 84	BFV10157/001
		260 x 98	-
27	- REJILLA DEFLECTORA		BFC08201/017
28	- CIERRE EN ASPIRACIÓN		BFC04152/011
29	- MOTORREDUCTOR	SQM50.381A2	M212/91
30	- SOPORTE		BFT05104/201
31	- ACOPLAMIENTO VENTILADOR		BFV10201/4
32	- ACOPLAMIENTO GOMA		BFV10201/6
33	- ACOPLAMIENTO INTERMEDIO		BFV10201/1
34	- ACOPLAMIENTO BOMBA		BFV10201/2
35	- TERMOSTATO	IMIT TR2 40/200	R801/2
36	- FILTRO		BFP01112
37	- RESISTENCIAS	3000 W	R119
		4650 W	-
38	- PRECALENTADOR		BFP01010/017
39	- CABLE	TC	BFE01403/1
		TL	BFE01403/3
40	- ANELLO PORTA BOBINA		BFT15224/001
41	- PORTA MOLLA		BFT15222/001
42	- CABEZA DE COMBUSTIÓN		
43	- TUBO		
44	- ALFILER PORTACHICLER		BLT01008
45	- SUPPORTO ASTA SPILLO		BLT01009/001
46	- SOPORTE PORTACHICLER		
47	- PORTACHICLER		BFC11019
48	- ELÉCTRODO		E612
49	- DIFUSOR		BFD05010/051
50	- TUBO LLAMA	TC	BFB05005/121
		TL	BFB05005/221
51	- TUBO LLAMA FINAL		BFB21009
52	- JUNTA		BFG03001/3
53	- JUNTA		BFG03002/3
54	- SURPRESSEUR		BFC08053/001
OILFLAM D			
55	- CALENTADOR		BFT15212/1
56	- PLATINA		BFT15212/2
57	- RESISTENCIAS	50 W	R110
VERSION MD			
58	- KIT CENTRALINA MODULANTE	RWF 40.000A97	E2490/5514

TC = CABEZA CORTA TL = CABEZA LARGA

№	НАИМЕНОВАНИЕ		OILFLAM 50.1 PR код	OILFLAM 80.1 PR код
1	- НАСОС	SUNTEC E4NC	P106	P106
2	- НАГРЕВАТЕЛЬНЫЙ ЭЛЕМЕНТ НАСОСА	50 W	R110	R110
3	- ГИБКИЕ ШЛАНГИ	1" A	S901	S901
4	- КАТУШКА	EL011	V523	V523
5	- ДЕРЖАТЕЛЬ КАТУШКИ	EL011	V1119/07	V1119/07
6	- МАНОМЕТР		S601/1	S601/1
7	- КРЫШКА			
8	- СТЕКЛО			
9	- РАМКА СМОТРОВОГО СТЕКЛА			
10	- ДВИГАТЕЛЬ	1500 W	M174/2	M174/2
11	- МОНТАЖНАЯ ПЛАСТИНА АППАРАТУРЫ	LANDIS	A402	A402
12	- КОНТРОЛЬНАЯ АППАРАТУРА	LMO44.255A2	A112/2	A112/2
13	- МОНТАЖНАЯ ПЛАСТИНА РЕЛЕ	FINDER (9474) R5534	R906	R906
14	- РЕЛЕ	FINDER 5534	R712	R712
15	- ПУСКАТЕЛЬ НАГРЕВАТЕЛЬНЫХ ЭЛЕМЕНТОВ	AEG LS05.10	R621	R621
		AEG LS4K.10	R621/1	R621/1
16	- ПУСКАТЕЛЬ ДВИГАТЕЛЯ	AEG LS05.10	R621	R621
17	- ТЕПЛОВОЕ РЕЛЕ ДВИГАТЕЛЯ	AEG 4-6,3 A	R521/4	R521/4
18	- ФИЛЬТР ПОДАВЛЕНИЯ ПОМЕХ		S132/4	S132/4
19	- ТЕРМОМЕТР	IMIT sc.0-200	R301/2	R301/2
20	- ВЫКЛЮЧАТЕЛЬ ГОРЕЛКИ	cod.40100I1509	R1020	R1020
21	- ПЕРЕКЛЮЧАТЕЛЬ		R1020/5	R1020/5
22	- ЛАМПОЧКА	EL/N-SC4 Elettrospring	E1510	E1510
23	- ШТЕКЕР WIELAND		E222	E222
24	- ТРАНСФОРМАТОР	BRAHMA T8	T101	T101
25	- ФОТОДАТЧИК	LANDIS	A207/1	A207/1
26	- РАБОЧЕЕ КОЛЕСО ВЕНТИЛЯТОРА	250 x 84 260 x 98	BFV10157/001	-
27	- ВОЗДУХОВОД		-	BFV10156/001
28	- КОЖУХ ВОЗДУХОВОДА		BFC08201/017	BFC08201/017
29	- СЕРВОПРИВОД	SQM50.381A2	BFC04152/011	BFC04152/011
30	- ШТОК		M212/91	M212/91
31	- МУФТА РАБОЧЕГО КОЛЕСА ВЕНТИЛЯТОРА		BFT05104/201	BFT05104/201
32	- РЕЗИНОВАЯ МУФТА		BFV10201/4	BFV10201/4
33	- ПРОМЕЖУТОЧНАЯ МУФТА		BFV10201/6	BFV10201/6
34	- МУФТА НАСОСА		BFV10201/1	BFV10201/1
35	- ТЕРМОСТАТ	IMIT TR2 40/200	BFV10201/2	BFV10201/2
36	- ФИЛЬТР		R801/2	R801/2
37	- НАГРЕВАТЕЛЬНЫЕ ЭЛЕМЕНТЫ	3000 W 4650 W	BFP01112	BFP01112
			R119	-
38	- БАЧОК - ПОДОГРЕВАТЕЛЬ		-	R120
39	- ПРОВОД	TC	BFP01010/017	BFP01011/017
		TL	BFE01403/1	BFE01403/1
40	- КОЛЬЦО		BFE01403/3	BFE01403/3
41	- ДЕРЖАТЕЛЬ ПРУЖИНЫ		BFT15224/001	BFT15224/001
42	- ОГНЕВАЯ ГОЛОВКА В СБОРЕ		BFT15222/001	BFT15222/001
43	- ТРУБКА ОГНЕВОЙ ГОЛОВКИ			
44	- ШТОК СО ШТИФТОМ		BLT01008	
45	- ШТАНГА ШТОК СО ШТИФТОМ		BLT01009/001	
46	- ЭЛЕКТРОДЫ			
47	- ДЕРЖАТЕЛЬ ФОРСУНКИ		BFC11019	BFC11019
48	- ЭЛЕКТРОДЫ		E612	E612
49	- РАССЕКАТЕЛЬ		BFD05010/051	BFD05010/051
50	- СТАКАН	TC	BFB05005/121	BFB05005/121
		TL	BFB05005/221	BFB05005/221
51	- КОЛПАК ИЗ НЕРЖАВЕЮЩЕЙ СТАЛИ		BFB21009	BFB21009
52	- ПРОКЛАДКА		BFG03001/3	BFG03001/3
53	- ПРОКЛАДКА		BFG03002/3	BFG03002/3
54	- ДЕФЛЕКТОР		BFC08053/001	BFC08053/001
Модификация D				
55	- НАГРЕВАТЕЛЬНЫЙ ЭЛЕМЕНТ		BFT15212/1	BFT15215/1
56	- ПЛАСТИНА		BFT15212/2	BFT15215/2
57	- НАГРЕВАТЕЛЬНЫЙ ЭЛЕМЕНТ	50 W	R110	R110
Модификация MD				
58	- МОДУЛЯЦИОННЫЙ РЕГУЛЯТОР	RWF 40.000A97	E2490/5514	E2490/5514

TC = КОРОТКАЯ ГОЛОВКА TL = ДЛИННАЯ ГОЛОВКА

N°	DESCRIZIONE	OILFLAM 120.1 PR codice
1	- POMPA	SUNTEC E7 NC P104
2	- RESISTENZA POMPA	50 W R110
3	- FLESSIBILI	1° A S901
4	- BOBINA	EL011 V523
5	- CONETTORE BOBINA	EL011 V1119/07
6	- MANOMETRO	S601/1
7	- COPERCHIO	
8	- VETRINO	
9	- SUPPORTO VETRINO	
10	- MOTORE	2200 W M167
11	- ZOCCOLO	LANDIS A402
12	- APPARECCHIATURA DI CONTROLLO	LMO44.255A2 A112/2
13	- ZOCCOLO RELE'	FINDER 95.75 (R.40.52) R910
14	- RELE'	FINDER MINI 40.52 R712/1
15	- CONTATTORE RESISTENZE	AEG LS05.10 R621 AEG LS4K.10 R621/1
16	- CONTATTORE MOTORE	AEG LS05.10 R621
17	- RELE' TERMICO MOTORE	AEG 4-6,3 A R521/4
18	- FILTRO ANTIDISTURBO	S132/4
19	- TERMOMETRO	IMIT sc.0-200 R301/2
20	- INTERRUTTORE BIPOLARE CON LED VERDE	cod.40100I1509 R1020
21	- SELETTORE	R1020/5
22	- LAMPADA	EL/N-SC4 Elettrospring E1510
23	- SPINA WIELAND	E222
24	- TRASFORMATORE	BRAHMA T8 T101
25	- FOTOSENSIBILITÀ	LANDIS A207/1
26	- VENTOLA	260 x 110 BFV10151/001
27	- CONVOGLIATORE	BFC08201/017
28	- CASSETTO	BFC04152/011
29	- MOTORIDUTTORE	SQM50.381A2 M212/91
30	- PERNO	BFT05104/201
31	- GIUNTO VENTOLA	BFV10201/4
32	- GIUNTO GOMMA	BFV10201/6
33	- GIUNTO INTERMEDIO	BFV10201/1
34	- GIUNTO POMPA	BFV10201/2
35	- TERMOSTATO	IMIT TR2 40/200 R801/2
36	- FILTRO	BFP01114
37	- RESISTENZE	7050 W R121
38	- BARILOTTO	BFP01009/017
39	- CAVO	TC BFE01403/1 TL BFE01403/3
40	- ANELLO PORTA BOBINA	BFT15224/001
41	- PORTA MOLLA	BFT15222/001
42	- TESTA DI COMBUSTIONE	BFT15249/001
43	- TUBO	BFT15250/001
44	- ASTA SPILLO	BLT01008
45	- SUPPORTO ASTA SPILLO	BLT01048/001
46	- CROCIERA	BFC10040/001
47	- PORTA UGELLO	BFC11019
48	- ELETTRODI	E612
49	- DIFFUSORE	BFD05009/051
50	- BOCCAGLIO	TC BFB05005/121 TL BFB05005/221
51	- CAMPANA INOX	BFB21009
52	- GUARNIZIONE	BFG03001/3
53	- GUARNIZIONE	BFG03002/3
54	- SURPRESSORE	BFC08053/001
OILFLAM D		
55	- BLOCCHETTO PRERISCALDATORE	BFT15212/1
56	- PIASTRINA	BFT15212/2
57	- RESISTENZA	50 W R110
VERSION MD		
58	- KIT CENTRALINA MODULANTE	RWF 40.000A97 E2490/5514

TC = TESTA CORTA

TL = TESTA LUNGA

N°	DESCRIPTION	OILFLAM 120.1 PR code
1	- PUMP	SUNTEC E7 NC P104
2	- HEATING ELEMENT PUMP	50 W R110
3	- HOSES	1" A S901
4	- COIL	EL011 V523
5	- CONETTORE BOBINA	EL011 V1119/07
6	- MANOMETER	S601/1
7	- COVER	
8	- GLASS	
9	- PEEP WINDOW FRAME	
10	- MOTOR	2200 W M167
11	- CONTROL BOX BASE	LANDIS A402
12	- CONTROL BOX	LMO44.255A2 A112/2
13	- RELAY BASE	FINDER 95.75 (R.40.52) R910
14	- RELAY	FINDER MINI 40.52 R712/1
15	- REMOTE CONTROL SWITCH	AEG LS05.10 R621 AEG LS4K.10 R621/1
16	- REMOTE CONTROL SWITCH MOTOR	AEG LS05.10 R621
17	- MOTOR THERMAL RELAY	AEG 4-6,3 A R521/4
18	- ANTIJAMMING FILTER	S132/4
19	- THERMOMETER	IMIT sc.0-200 R301/2
20	- MAIN SWITCH	cod.40100I1509 R1020
21	- SELECTOR	R1020/5
22	- LAMP	EL/N-SC4 Elettrospring E1510
23	- PLUG WIELAND	E222
24	- IGNITION TRANSFORMER	BRAHMA T8 T101
25	- PHOTORESISTOR	LANDIS A207/1
26	- FAN	260 x 110 BFV10151/001
27	- AIR CONVEYOR	BFC08201/017
28	- COVER AIR INLET	BFC04152/011
29	- AIR DAMPER MOTOR	SQM50.381A2 M212/91
30	- ROD	BFT05104/201
31	- COUPLING (FAN)	BFV10201/4
32	- UNION	BFV10201/6
33	- COUPLING	BFV10201/1
34	- COUPLING (PUMP)	BFV10201/2
35	- THERMOSTAT	IMIT TR2 40/200 R801/2
36	- FILTER	BFP01114
37	- HEATER	7050 W R121
38	- OIL TANK	BFP01009/017
39	- CABLE	TC BFE01403/1 TL BFE01403/3
40	- RING	BFT15224/001
41	- HOLDER SPRING	BFT15222/001
42	- FIRING HEAD	BFT15249/001
43	- PIPE	BFT15250/001
44	- ROD NOZZLE	BLT01008
45	- ROD NOZZLE HOLDER	BLT01048/001
46	- SUPPORT NOZZLE HOLDER	BFC10040/001
47	- NOZZLE HOLDER	BFC11019
48	- ELECTRODES	E612
49	- DIFFUSER	BFD05009/051
50	- BLAST TUBE	TC BFB05005/121 TL BFB05005/221
51	- BLAST TUBE END	BFB21009
52	- GASKET	BFG03001/3
53	- GASKET	BFG03002/3
54	- FAN SCOOP	BFC08053/001
OILFLAM D		
55	- PREHEATED'S AUX. RESISTOR HOLDER	BFT15212/1
56	- FIXING PLATE	BFT15212/2
57	- HEATING ELEMENT	50 W R110
VERSION MD		
58	- KIT MODULATING UNIT	RWF 40.000A97 E2490/5514

TC = SHORT HEAD TL = LONG HEAD

N°	DESIGNATION	OILFLAM 120.1 PR code
1	- POMPE SUNTEC E7 NC	P104
2	- RESISTANCES 50 W	R110
3	- FLEXIBLES 1° A	S901
4	- BOBINE EL011	V523
5	- CONETTORE BOBINA EL011	V1119/07
6	- MANOMETRE	S601/1
7	- COUVERCHE DE BRULEUR	
8	- HUBLLOT	
9	- PROTECTION HUBLLOT	
10	- MOTEUR 2200 W	M167
11	- SOCLE DE COFFRET LANDIS	A402
12	- COFFRET DE SECURITE LMO44.255A2	A112/2
13	- SOCLE DE RELAIS FINDER 95.75 (R.40.52)	R910
14	- RELAIS FINDER MINI 40.52	R712/1
15	- TELERUPTEUR DE RESISTANCES AEG LS05.10	R621
	AEG LS4K.10	R621/1
16	- TELERUPTEUR DE MOTEUR AEG LS05.10	R621
17	- RELAIS THERMIQUE AEG 4-6,3 A	R521/4
18	- FILTRE ANTIPARASITE	S132/4
19	- THERMOMETRE IMIT sc.0-200	R301/2
20	- INTERRUPTEUR DE LIGNE cod.40100I1509	R1020
21	- SELECTOR	R1020/5
22	- LAMPE EL/N-SC4 Elettrospring	E1510
23	- FICHE MALE WIELAND	E222
24	- TRANSFORMATEUR BRAHMA T8	T101
25	- CELLULE LANDIS	A207/1
26	- TURBINE 260 x 110	BFV10151/001
27	- CONVOYEUR D'AIR	BFC08201/017
28	- BOITE D'AIR	BFC04152/011
29	- SERVOMOTEUR SQM50.381A2	M212/91
30	- ARBRE DE TRASMISSION	BFT05104/201
31	- JOINT DU VENTILATEUR	BFV10201/4
32	- JOINT DE CAOUTCHOUC	BFV10201/6
33	- JOINT INTERMEDIAIRE	BFV10201/1
34	- JOINT DE LA POMPE	BFV10201/2
35	- THERMOSTAT IMIT TR2 40/200	R801/2
36	- FILTRE	BFP01114
37	- RESISTANCES 7050 W	R121
38	- RECHAUFFAGE	BFP01009/017
39	- CABLE TC	BFE01403/1
	TL	BFE01403/3
40	- ANELLO PORTA BOBINA	BFT15224/001
41	- PORTA MOLLA	BFT15222/001
42	- TETE DE COMBUSTION	BFT15249/001
43	- TUYAU	BFT15250/001
44	- TIGE PORTE GICLEUR	BLT01008
45	- SUPPORTO ASTA SPILLO	BLT01048/001
46	- SUPPORT PORTE GICLEUR	BFC10040/001
47	- PORTE GICLEUR	BFC11019
48	- ELECTRODE D'ALLUMAGE	E612
49	- DEFLECTEUR	BFD05009/051
50	- GUEULARD TC	BFB05005/121
	TL	BFB05005/221
51	- TERMINAL INOX	BFB21009
52	- JOINT	BFG03001/3
53	- JOINT	BFG03002/3
54	- SURPRESSEUR	BFC08053/001
OILFLAM D		
55	- RECHAUFFEUR	BFT15212/1
56	- PLAQUETTE	BFT15212/2
57	- RESISTANCES 50 W	R110
VERSION MD		
58	- KIT CENTRALINA MODULANTE RWF 40.000A97	E2490/5514

TC = TETE COURTE TL = TETE LONGUE

N°	DESCRIPCIÓN	OILFLAM 120.1 PR código
1	- BOMBA	SUNTEC E7 NC P104
2	- RESISTENCIA BOMBA	50 W R110
3	- LATIGUILLOS	1° A S901
4	- BOBINA	EL011 V523
5	- CONETTORE BOBINA	EL011 V1119/07
6	- MANOMETRO	S601/1
7	- TAPA	
8	- VIDRIOSO	
9	- SOPORTE VIDRIOSO	
10	- MOTOR	2200 W M167
11	- BASE DEL EQUIPO	LANDIS A402
12	- EQUIPO CONTROL LLAMA	LMO44.255A2 A112/2
13	- BASE DEL RELE'	FINDER 95.75 (R.40.52) R910
14	- RELE'	FINDER MINI 40.52 R712/1
15	- CONTACTOR RESISTENCIAS	AEG LS05.10 R621
		AEG LS4K.10 R621/1
16	- CONTACTOR MOTOR	AEG LS05.10 R621
17	- EMPALME MOTOR VENTILADOR	AEG 4-6,3 A R521/4
18	- FILTRO ANTITRASTORNO	S132/4
19	- TERMOMETRO	IMIT sc.0-200 R301/2
20	- INTERRUPTOR DE LINEA	cod.40100I1509 R1020
21	- CONMUTADOR	R1020/5
22	- ESPIA	EL/N-SC4 Elettrospring E1510
23	- TOMA WIELAND	E222
24	- TRANSFORMADOR	BRAHMA T8 T101
25	- FOTORRESISTENCIA	LANDIS A207/1
26	- VENTILADOR	260 x 110 BFV10151/001
27	- REJILLA DEFLECTORA	BFC08201/017
28	- CIERRE EN ASPIRACIÓN	BFC04152/011
29	- MOTORREDUCTOR	SQM50.381A2 M212/91
30	- SOPORTE	BFT05104/201
31	- ACOPLAMIENTO VENTILADOR	BFV10201/4
32	- ACOPLAMIENTO GOMA	BFV10201/6
33	- ACOPLAMIENTO INTERMEDIO	BFV10201/1
34	- ACOPLAMIENTO BOMBA	BFV10201/2
35	- TERMOSTATO	IMIT TR2 40/200 R801/2
36	- FILTRO	BFP01114
37	- RESISTENCIAS	7050 W R121
38	- PRECALENTADOR	BFP01009/017
39	- CABLE	TC BFE01403/1
		TL BFE01403/3
40	- ANELLO PORTA BOBINA	BFT15224/001
41	- PORTA MOLLA	BFT15222/001
42	- CABEZA DE COMBUSTIÓN	BFT15249/001
43	- TUBO	BFT15250/001
44	- ALFILER PORTACHICLER	BLT01008
45	- SUPPORTO ASTA SPILLO	BLT01048/001
46	- SOPORTE PORTACHICLER	BFC10040/001
47	- PORTACHICLER	BFC11019
48	- ELÉCTRODO	E612
49	- DIFUSOR	BFD05009/051
50	- TUBO LLAMA	TC BFB05005/121
		TL BFB05005/221
51	- TUBO LLAMA FINAL	BFB21009
52	- JUNTA	BFG03001/3
53	- JUNTA	BFG03002/3
54	- SURPRESSEUR	BFC08053/001
OILFLAM D		
55	- CALENTADOR	BFT15212/1
56	- PIASTRINA	BFT15212/2
57	- RESISTENCIAS	50 W R110
VERSION MD		
58	- KIT CENTRALINA MODULANTE	RWF 40.000A97 E2490/5514

TC = CABEZA CORTA TL = CABEZA LARGA

N°	НАИМЕНОВАНИЕ	OILFLAM 120.1 PR код
1	- НАСОС SUNTEC E7 NC	P104
2	- НАГРЕВАТЕЛЬНЫЙ ЭЛЕМЕНТ НАСОСА 50 W	R110
3	- ГИБКИЕ ШЛАНГИ 1" A	S901
4	- КАТУШКА EL011	V523
5	- ДЕРЖАТЕЛЬ КАТУШКИ EL011	V1119/07
6	- МАНОМЕТР	S601/1
7	- КРЫШКА	
8	- СТЕКЛО	
9	- РАМКА СМОТРОВОГО СТЕКЛА	
10	- ДВИГАТЕЛЬ 2200 W	M167
11	- МОНТАЖНАЯ ПЛАСТИНА АППАРАТУРЫ LANDIS	A402
12	- КОНТРОЛЬНАЯ АППАРАТУРА LMO44.255A2	A112/2
13	- МОНТАЖНАЯ ПЛАСТИНА РЕЛЕ FINDER 95.75 (R.40.52)	R910
14	- РЕЛЕ FINDER MINI 40.52	R712/1
15	- ПУСКАТЕЛЬ НАГРЕВАТЕЛЬНЫХ ЭЛЕМЕНТОВ AEG LS05.10	R621
	AEG LS4K.10	R621/1
16	- ПУСКАТЕЛЬ ДВИГАТЕЛЯ AEG LS05.10	R621
17	- ТЕПЛОЕ РЕЛЕ ДВИГАТЕЛЯ AEG 4-6,3 A	R521/4
18	- ФИЛЬТР ПОДАВЛЕНИЯ ПОМЕХ	S132/4
19	- ТЕРМОМЕТР IMIT sc.0-200	R301/2
20	- ВЫКЛЮЧАТЕЛЬ ГОРЕЛКИ cod.4010011509	R1020
21	- ПЕРЕКЛЮЧАТЕЛЬ	R1020/5
22	- ЛАМПОЧКА EL/N-SC4 Elettrospring	E1510
23	- ШТЕКЕР WIELAND	E222
24	- ТРАНСФОРМАТОР BRAHMA T8	T101
25	- ФОТОДАТЧИК LANDIS	A207/1
26	- РАБОЧЕЕ КОЛЕСО ВЕНТИЛЯТОРА 260 x 110	BFV10151/001
27	- ВОЗДУХОВОД	BFC08201/017
28	- КОЖУХ ВОЗДУХОВОДА	BFC04152/011
29	- СЕРВОПРИВОД SQM50.381A2	M212/91
30	- ШТОК	BFT05104/201
31	- МУФТА РАБОЧЕГО КОЛЕСА ВЕНТИЛЯТОРА	BFV10201/4
32	- РЕЗИНОВАЯ МУФТА	BFV10201/6
33	- ПРОМЕЖУТОЧНАЯ МУФТА	BFV10201/1
34	- МУФТА НАСОСА	BFV10201/2
35	- ТЕРМОСТАТ IMIT TR2 40/200	R801/2
36	- ФИЛЬТР	BFP01114
37	- НАГРЕВАТЕЛЬНЫЕ ЭЛЕМЕНТЫ 7050 W	R121
38	- БАЧОК - ПОДОГРЕВАТЕЛЬ	BFP01009/017
39	- ПРОВОД TC	BFE01403/1
	TL	BFE01403/3
40	- КОЛЬЦО	BFT15224/001
41	- ДЕРЖАТЕЛЬ ПРУЖИНЫ	BFT15222/001
42	- ОГНЕВАЯ ГОЛОВКА В СБОРЕ	BFT15249/001
43	- ТРУБКА ОГНЕВОЙ ГОЛОВКИ	BFT15250/001
44	- ШТОК СО ШТИФТОМ	BLT01008
45	- ШТАНГА ШТОК СО ШТИФТОМ	BLT01048/001
46	- ЭЛЕКТРОДЫ	BFC10040/001
47	- ДЕРЖАТЕЛЬ ФОРСУНКИ	BFC11019
48	- ЭЛЕКТРОДЫ	E612
49	- РАССЕКАТЕЛЬ	BFD05009/051
50	- СТАКАН TC	BFB05005/121
	TL	BFB05005/221
51	- КОЛПАК ИЗ НЕРЖАВЕЮЩЕЙ СТАЛИ	BFB21009
52	- ПРОКЛАДКА	BFG03001/3
53	- ПРОКЛАДКА	BFG03002/3
54	- ДЕФЛЕКТОР	BFC08053/001
Модификация D		
55	- НАГРЕВАТЕЛЬНЫЙ ЭЛЕМЕНТ	BFT15212/1
56	- ПЛАСТИНА	BFT15212/2
57	- НАГРЕВАТЕЛЬНЫЙ ЭЛЕМЕНТ 50 W	R110
Модификация MD		
58	- МОДУЛЯЦИОННЫЙ РЕГУЛЯТОР RWF 40.000A97	E2490/5514

TC = КОРОТКАЯ ГОЛОВКА TL = ДЛИННАЯ ГОЛОВКА

N°	DESCRIZIONE	OILFLAM 170.1 PR codice	OILFLAM 200.1 PR codice
1	- POMPA	SUNTE 7NC	P104
2	- RESISTENZA POMPA	50 W	R110
3	- FLESSIBILI	1" A	S901
		1" C/Molla	S901/2
4	- BOBINA	EL011	V523
5	- CONETTORE BOBINA	EL011	V1119/07
6	- MANOMETRO		S601/1
7	- COPERCHIO		BFC09204/038
8	- VETRINO		BFC02004
9	- SUPPORTO VETRINO		BFC02006
10	- MOTORE	4000 W	M127/017
11	- ZOCCOLO	LANDIS	A402
12	- APPARECCHIATURA DI CONTROLLO	LMO44.255A2	A112/2
13	- ZOCCOLO RELE'	FINDER (9474) R5534	R906
14	- RELE'	FINDER 5534	R712
15	- CONTATTORE RESISTENZE	AEG LS4K.10	R621/1
		AEG LS11K.00	R621/4
16	- CONTATTORE MOTORE	AEG LS4K.10	R621/1
17	- RELE' TERMICO MOTORE	AEG 8-12,5A	R521/5
18	- FILTRO ANTIDISTURBO		S132/4
19	- TERMOMETRO	IMIT sc.0-200	R301/2
20	- INTERRUTTORE BIPOLARE CON LED VERDE	cod.40100I1509	R1020
21	- SELETTORE		R1020/5
22	- LAMPADA	EL/N-SC4 Elettrospring	E1510
23	- SPINA WIELAND		E222
24	- TRASFORMATORE	BRAHMA T8	T101
25	- FOTORESISTENZA	LANDIS	A207/1
26	- VENTOLA	280 x 140	BFV10301/001
27	- CONVOGLIATORE		BFC08252/201
28	- CASSETTO		BFC04154/038
29	- MOTORIDUTTORE	SQM50.381A2	M212/91
30	- PERNO		
31	- GIUNTO VENTOLA		BFV10203/1
32	- GIUNTO GOMMA VENTOLA		BFV10203/4
33	- GIUNTO INTERMEDIO VENTOLA		BFV10203/3
34	- GIUNTO INTERMEDIO POMPA		BFV10201/1
35	- GIUNTO GOMMA POMPA		BFV10201/6
36	- GIUNTO POMPA		BFV10201/2
37	- TERMOSTATO	IMIT TR2 40/200	R801/2
38	- FILTRO		BFP01114
39	- RESISTENZE	9000 W	R122
		10500 W	R123
40	- BARILOTTO		BFP01033/017
41	- CAVO	TC	BFE01403/1
		TL	BFE01403/3
42	- ANELLO PORTA BOBINA		BFT15224/001
43	- PORTA MOLLA		BFT15222/001
44	- TESTA DI COMBUSTIONE		
45	- TUBO		
46	- ASTA SPILLO		BLT01008
47	- SUPPORTO ASTA SPILLO		BLT01009/001
48	- SUPPORTO FASCIA		-
49	- FASCIA		-
50	- CROCIERA		
51	- PORTA UGELLO		BFC11019
52	- ELETTRODI		E612
53	- DIFFUSORE		
54	- BOCCAGLIO	TC	BFB07030/103
		TL	BFB07030/203
55	- CAMPANA INOX		BFB07030/3
56	- GUARNIZIONE		BFB07030/4
57	- GUARNIZIONE		BFG04007
58	- SILENZIATORE		BFG04051/3
59	- SURPRESSORE		-
			GRSIL03
			BFC08057/001
		OILFLAM D	
60	- BLOCCETTO PRERISCALDATORE		BFT15212/1
61	- PIASTRINA		BFT15212/2
62	- RESISTENZA	50 W	R110
			R110
		VERSION MD	
63	- KIT CENTRALINA MODULANTE	RWF 40.000A97	E2490/5514

TC = TESTA CORTA

TL = TESTA LUNGA

N°	DESCRIPTION	OILFLAM 170.1 PR code	OILFLAM 200.1 PR code
1	- PUMP	SUNTE 7NC	P104
2	- HEATING ELEMENT PUMP	50 W	R110
3	- HOSES	1" A	S901
		1" C/Molla	S901/2
4	- COIL	EL011	V523
5	- CONETTORE BOBINA	EL011	V1119/07
6	- MANOMETER		S601/1
7	- COVER		BFC09204/038
8	- GLASS		BFC02004
9	- PEEP WINDOW FRAME		BFC02006
10	- MOTOR	4000 W	M127/017
11	- CONTROL BOX BASE	LANDIS	A402
12	- CONTROL BOX	LMO44.255A2	A112/2
13	- RELAY BASE	FINDER (9474) R5534	R906
14	- RELAY	FINDER 5534	R712
15	- REMOTE CONTROL SWITCH	AEG LS4K.10	R621/1
		AEG LS11K.00	R621/4
16	- REMOTE CONTROL SWITCH MOTOR	AEG LS4K.10	R621/1
17	- MOTOR THERMAL RELAY	AEG 8-12,5A	R521/5
18	- ANTIJAMMING FILTER		S132/4
19	- THERMOMETER	IMIT sc.0-200	R301/2
20	- MAIN SWITCH	cod.40100I1509	R1020
21	- SELECTOR		R1020/5
22	- LAMP	EL/N-SC4 Elettrospring	E1510
23	- PLUG WIELAND		E222
24	- IGNITION TRANSFORMER	BRAHMA T8	T101
25	- PHOTORESISTOR	LANDIS	A207/1
26	- FAN	280 x 140	BFV10301/001
27	- AIR CONVEYOR		BFC08252/201
28	- COVER AIR INLET		BFC04154/038
29	- AIR DAMPER MOTOR	SQM50.381A2	M212/91
30	- ROD		
31	- COUPLING (FAN)		BFV10203/1
32	- UNION (FAN)		BFV10203/4
33	- COUPLING		BFV10203/3
34	- COUPLING		BFV10201/1
35	- UNION (PUMP)		BFV10201/6
36	- COUPLING (PUMP)		BFV10201/2
37	- THERMOSTAT	IMIT TR2 40/200	R801/2
38	- FILTER		BFP01114
39	- HEATER	9000 W	R122
		10500 W	-
40	- OIL TANK		BFP01033/017
41	- CABLE	TC	BFE01403/1
		TL	BFE01403/3
42	- RING		BFT15224/001
43	- HOLDER SPRING		BFT15222/001
44	- FIRING HEAD		
45	- PIPE		
46	- ROD NOZZLE		BLT01008
47	- ROD NOZZLE HOLDER		BLT01009/001
48	- HOLDER WAISTBAND		-
49	- WAISTBAND		-
50	- SUPPORT NOZZLE HOLDER		
51	- NOZZLE HOLDER		BFC11019
52	- ELECTRODES		E612
53	- DIFFUSER		
54	- BLAST TUBE	TC	BFB07030/103
		TL	BFB07030/203
55	- BLAST TUBE END		BFB07030/3
56	- GASKET		BFG04007
57	- GASKET		BFG04051/3
58	- SILENCER		-
59	- FAN SCOOP		GRSIL03
			BFC08057/001
OILFLAM D			
60	- PREHEATED'S AUX. RESISTOR HOLDER		BFT15212/1
61	- FIXING PLATE		BFT15212/2
62	- HEATING ELEMENT	50 W	R110
			R110
VERSION MD			
63	- KIT MODULATING UNIT	RWF 40.000A97	E2490/5514
			E2490/5514

TC = SHORT HEAD TL = LONG HEAD

N°	DESCRIPCIÓN	OILFLAM 170.1 PR código	OILFLAM 200.1 PR código
1	- BOMBA SUNTE 7NC	P104	P104
2	- RESISTENCIA BOMBA 50 W	R110	R110
3	- LATIGUILLOS 1" A 1" C/Molla	S901 S901/2	S901 S901/2
4	- BOBINA EL011	V523	V523
5	- CONETTORE BOBINA EL011	V1119/07	
6	- MANÓMETRO S601/1	S601/1	S601/1
7	- TAPA BFC09204/038	BFC09204/038	BFC09204/038
8	- VIDRIOSOS BFC02004	BFC02004	BFC02004
9	- SOPORTE VIDRIOSOS BFC02006	BFC02006	BFC02006
10	- MOTOR 4000 W	M127/017	M127/017
11	- BASE DEL EQUIPO LANDIS	A402	A402
12	- EQUIPO CONTROL LLAMA LMO44.255A2	A112/2	A112/2
13	- BASE DEL RELE' FINDER (9474) R5534	R906	R906
14	- RELE' FINDER 5534	R712	R712
15	- CONTACTOR RESISTENCIAS AEG LS4K.10	R621/1	R621/1
	AEG LS11K.00	R621/4	R621/4
16	- CONTATTORE MOTORE AEG LS4K.10	R621/1	R621/1
17	- EMPALME MOTOR VENTILADOR AEG 8-12,5A	R521/5	R521/5
18	- FILTRO ANTITRATORNO S132/4	S132/4	S132/4
19	- TERMOMETRO IMIT sc.0-200	R301/2	R301/2
20	- INTERRUPTOR DE LINEA cod.4010011509	R1020	R1020
21	- CONMUTADOR R1020/5	R1020/5	R1020/5
22	- ESPIA EL/N-SC4 Elettrospring	E1510	E1510
23	- TOMA WIELAND E222	E222	E222
24	- TRANSFORMADOR BRAHMA T8	T101	T101
25	- FOTORRESISTENCIA LANDIS	A207/1	A207/1
26	- VENTILADOR 280 x 140	BFV10301/001	BFV10301/001
27	- REJILLA DEFLECTORA BFC08252/201	BFC08252/201	BFC08252/201
28	- CIERRE EN ASPIRACIÓN BFC04154/038	BFC04154/038	BFC04154/038
29	- MOTORREDUCTOR SQM50.381A2	M212/91	M212/91
30	- SOPORTE		
31	- ACOPLAMIENTO VENTILADOR	BFV10203/1	BFV10203/1
32	- ACOPLAMIENTO GOMA VENTILADOR	BFV10203/4	BFV10203/4
33	- ACOPLAMIENTO INTERMEDIO VENTILADOR	BFV10203/3	BFV10203/3
34	- ACOPLAMIENTO INTERMEDIO BOMBA	BFV10201/1	BFV10201/1
35	- ACOPLAMIENTO GOMA BOMBA	BFV10201/6	BFV10201/6
36	- ACOPLAMIENTO BOMBA	BFV10201/2	BFV10201/2
37	- TERMOSTATO IMIT TR2 40/200	R801/2	R801/2
38	- FILTRO BFP01114	BFP01114	BFP01114
39	- RESISTENCIAS 9000 W 10500 W	R122 -	- R123
40	- PRECALENTADOR	BFP01033/017	BFP01033/017
41	- CABLE TC TL	BFE01403/1 BFE01403/3	BFE01403/1 BFE01403/3
42	- ANELLO PORTA BOBINA	BFT15224/001	BFT15224/001
43	- PORTA MOLLA	BFT15222/001	BFT15222/001
44	- CABEZA DE COMBUSTIÓN		
45	- TUBO		
46	- ALFILER PORTACHICLER	BLT01008	
47	- SUPPORTO ASTA SPILLO	BLT01009/001	
48	- SUPPORTO FASCIA	-	
49	- FASCIA	-	
50	- SOPORTE CABEZA DE COMBUSTION		
51	- PORTACHICLER	BFC11019	
52	- ELÉCTRODO	E612	E612
53	- DIFUSOR		
54	- TUBO LLAMA TC TL	BFB07030/103 BFB07030/203	BFB07030/103 BFB07030/203
55	- TUBO LLAMA FINAL	BFB07030/3	BFB07030/4
56	- JUNTA	BFG04007	BFG04011
57	- JUNTA	BFG04051/3	BFG04051/3
58	- SILENCIADOR	-	GRSIL03
59	- SURPRESSEUR	-	BFC08057/001
	OILFLAM D		
60	- CALENTADOR	BFT15212/1	BFT15215/1
61	- PLATINA	BFT15212/2	BFT15215/2
62	- RESISTENCIAS 50 W	R110	R110
	VERSION MD		
63	- CENTRALITA MODULANTE RWF 40.000A97	E2490/5514	E2490/5514

TC = CABEZA CORTA TL = CABEZA LARGA

№	НАИМЕНОВАНИЕ		OILFLAM 170.1 PR код	OILFLAM 200.1 PR код
1	- НАСОС	SUNTE 7NC	P104	P104
2	- НАГРЕВАТЕЛЬНЫЙ ЭЛЕМЕНТ НАСОСА	50 W	R110	R110
3	- ГИБКИЕ ШЛАНГИ	1" A	S901	S901
		1" C/Molla	S901/2	S901/2
4	- КАТУШКА	EL011	V523	V523
5	- ДЕРЖАТЕЛЬ КАТУШКИ	EL011	V1119/07	V1119/07
6	- МАНОМЕТР		S601/1	S601/1
7	- КРЫШКА		BFC09204/038	BFC09204/038
8	- СТЕКЛО		BFC02004	BFC02004
9	- РАМКА СМОТРОВОГО СТЕКЛА		BFC02006	BFC02006
10	- ДВИГАТЕЛЬ	4000 W	M127/017	M127/017
11	- МОНТАЖНАЯ ПЛАСТИНА АППАРАТУРЫ	LANDIS	A402	A402
12	- КОНТРОЛЬНАЯ АППАРАТУРА	LMO44.255A2	A112/2	A112/2
13	- МОНТАЖНАЯ ПЛАСТИНА РЕЛЕ	FINDER (9474) R5534	R906	R906
14	- РЕЛЕ	FINDER 5534	R712	R712
15	- ПУСКАТЕЛЬ НАГРЕВАТЕЛЬНЫХ ЭЛЕМЕНТОВ	AEG LS4K.10	R621/1	R621/1
		AEG LS11K.00	R621/4	R621/4
16	- ПУСКАТЕЛЬ ДВИГАТЕЛЯ	AEG LS4K.10	R621/1	R621/1
17	- ТЕПЛОВОЕ РЕЛЕ ДВИГАТЕЛЯ	AEG 8-12,5A	R521/5	R521/5
18	- ФИЛЬТР ПОДАВЛЕНИЯ ПОМЕХ		S132/4	S132/4
19	- ТЕРМОМЕТР	IMIT sc.0-200	R301/2	R301/2
20	- ВЫКЛЮЧАТЕЛЬ ГОРЕЛКИ	cod.4010011509	R1020	R1020
21	- ПЕРЕКЛЮЧАТЕЛЬ		R1020/5	R1020/5
22	- ЛАМПОЧКА	EL/N-SC4 Elettrospring	E1510	E1510
23	- ШТЕКЕР WIELAND		E222	E222
24	- ТРАНСФОРМАТОР	BRAHMA T8	T101	T101
25	- ФОТОДАТЧИК	LANDIS	A207/1	A207/1
26	- РАБОЧЕЕ КОЛЕСО ВЕНТИЛЯТОРА	280 x 140	BFV10301/001	BFV10301/001
27	- ВОЗДУХОВОД		BFC08252/201	BFC08252/201
28	- КОЖУХ ВОЗДУХОВОДА		BFC04154/038	BFC04154/038
29	- СЕРВОПРИВОД	SQM50.381A2	M212/91	M212/91
30	- ШТОК			
31	- МУФТА РАБОЧЕГО КОЛЕСА ВЕНТИЛЯТОРА		BFV10203/1	BFV10203/1
32	- РЕЗИНОВАЯ МУФТА		BFV10203/4	BFV10203/4
33	- ПРОМЕЖУТОЧНАЯ МУФТА		BFV10203/3	BFV10203/3
34	- ПРОМЕЖУТОЧНАЯ МУФТА		BFV10201/1	BFV10201/1
35	- РЕЗИНОВАЯ МУФТА (НАСОСА)		BFV10201/6	BFV10201/6
36	- МУФТА НАСОСА		BFV10201/2	BFV10201/2
37	- ТЕРМОСТАТ	IMIT TR2 40/200	R801/2	R801/2
38	- ФИЛЬТР		BFP01114	BFP01114
39	- НАГРЕВАТЕЛЬНЫЕ ЭЛЕМЕНТЫ	9000 W	R122	-
		10500 W	-	R123
40	- БАЧОК - ПОДОГРЕВАТЕЛЬ		BFP01033/017	BFP01033/017
41	- ПРОВОД	TC	BFE01403/1	BFE01403/1
		TL	BFE01403/3	BFE01403/3
42	- КОЛЬЦО		BFT15224/001	BFT15224/001
43	- ДЕРЖАТЕЛЬ ПРУЖИНЫ		BFT15222/001	BFT15222/001
44	- ОГНЕВАЯ ГОЛОВКА В СБОРЕ			
45	- ТРУБКА ОГНЕВОЙ ГОЛОВКИ			
46	- ШТОК СО ШТИФТОМ		BLT01008	
47	- ШТАНГА ШТОК СО ШТИФТОМ		BLT01009/001	
48	- HOLDER WAISTBAND		-	
49	- WAISTBAND		-	
50	- ЭЛЕКТРОДЫ			
51	- ДЕРЖАТЕЛЬ ФОРСУНКИ		BFC11019	
52	- ЭЛЕКТРОДЫ		E612	E612
53	- РАССЕКАТЕЛЬ			
54	- СТАКАН	TC	BFB07030/103	BFB07030/103
		TL	BFB07030/203	BFB07030/203
55	- КОЛПАК ИЗ НЕРЖАВЕЮЩЕЙ СТАЛИ		BFB07030/3	BFB07030/4
56	- ПРОКЛАДКА		BFG04007	BFG04011
57	- ПРОКЛАДКА		BFG04051/3	BFG04051/3
58	- ГЛУШИТЕЛЬ		-	GRSIL03
59	- ДЕФЛЕКТОР		-	BFC08057/001
		Модификация D		
60	- НАГРЕВАТЕЛЬНЫЙ ЭЛЕМЕНТ		BFT15212/1	BFT15215/1
61	- ПЛАСТИНА		BFT15212/2	BFT15215/2
62	- НАГРЕВАТЕЛЬНЫЙ ЭЛЕМЕНТ	50 W	R110	R110
Модификация MD				
63	- МОДУЛЯЦИОННЫЙ РЕГУЛЯТОР	RWF 40.000A97	E2490/5514	E2490/5514

TC = КОРОТКАЯ ГОЛОВКА TL = ДЛИННАЯ ГОЛОВКА

La ECOFLAM BRUCIATORI S.p.A si riserva il diritto di apportare ai prodotti quelle modifiche che riterrà necessarie o utili, senza pregiudicarne le caratteristiche principali.

ECOFLAM BRUCIATORI S.p.A. reserves the right to make any adjustments, without prior notice, which it considers necessary or useful to its products, without affecting their main features.

La Maison ECOFLAM BRUCIATORI S.p.A. se réserve le droit d'apporter les modifications qu'elle jugera nécessaires ou utiles à ses produits sans pour autant nuire à leurs caractéristiques principales.

ECOFLAM BRUCIATORI S.p.A. se reserva el derecho a introducir en sus productos todas las modificaciones que considere necesarias o utiles, sin perjudicar sus características.

“Экофлам С.п.А.” оставляет за собой право вносить в конструкцию оборудования любые необходимые изменения без особого предупреждения.

Ecoflam

Ecoflam Bruciatori S.p.A.

via Roma, 64 - 31023 RESANA (TV) - Italy - tel. 0423.719500 - fax 0423.719580
<http://www.ecoflam-burners.com> - e-mail: export@ecoflam-burners.com

ТЕТАН Инженерные Системы
Партнер Ecoflam в Украине

ул. Здолбуновская 7-Д, г. Киев, Украина
тел./факс: +380 (44) 362 33 00
email: info@tetan.ua

tetan.ua

